

Uniting water with an abundant lifestyle ●●●●● Kawamoto Pump

Multi-stage Turbine Pump

T (TK) / TN / K(R)-M / KR-C / KR-4M Type

Instruction Manual

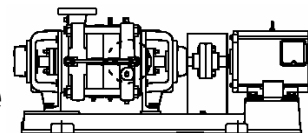

Thank you for purchasing the T (TK) / TN / K(R)-M / KR-C / KR-4M type multi-stage turbine pump. This instruction manual provides information for the constructor to safely use this pump unit. Always read this manual thoroughly and fully comprehend the contents before starting work. Please keep this instruction manual in a handy place for quick reference.

<Contents>

[1] Introduction.....	2	[6] Electrical Work.....	8
[2] Specifications	2	[7] Operation.....	9
[3] Product Configuration	3	[8] Maintenance and Inspection.....	10
[4] Installation	6	[9] Disassembly and Assembly.....	11
[5] Piping	7	[10] Troubleshooting.....	11

Special Notes

1. Securely earth the equipment, and install a dedicated residual current circuit breaker on the power supply side.
Failure to observe this could result in earth leakages, electric shocks or fires.
2. The electrical work must be completed according to the "Electrical Installation Technical Standards", "Wiring Regulations" and any other applicable regulations. Improper wiring and connections could lead to earth leakages or fires.
3. Do not run the pump in a dry mode (without water in the pump) or in a shutoff mode (without water inflow to, or discharge from, the pump). Such operations could cause the pump to become extremely hot, possibly resulting in burns.
4. Do not install this pump unit in a place that has not been treated for drainage or waterproofing. Major disasters could occur if water leaks.

Precautions for using this product safely and for preventing personal injuries or physical damage are given in this manual.

The precautions are classified as "Warning" and "Caution" to alert of the degree of injury or damage that could occur if handling is mistaken.

In either case, these are important matters related to safety, and must be observed.

 Warning : Details which if ignored could lead to fatalities or serious injuries.

 Caution : Details which if ignored could lead to personal injuries or physical damage.

[1] Introduction

Please check the following items upon receipt of the product.

- (1) Check the nameplate to ensure that the correct pump has been delivered.
Check the type, bore, total head, frequency, No. of phases, rated output, etc.
- (2) Check that no parts have been damaged during transportation, and that none of the bolts, nuts, etc., are loose. Tighten any part that is loose.
- (3) Check that all ordered accessories have been delivered.
<<If there is any problems, contact your dealer>>

[2] Specifications

- Always use this pump within the specified conditions.  **Caution**
Failure to do so could result in electric shocks, fires, water leaks, etc.

2.1 Specifications

		T (TK)	TN	K(R)-M	KR-C	KR4-M
Pumped, fluid	Fluid quality	Fresh water (PH 6.5 to 8)–	Fresh water (PH 6.5 to 8)–	Fresh water (PH 6.5 to 8)	Fresh water (PH 6.5 to 8)	Fresh water (PH 6.5 to 8)
	Fluid temp.	0 to 40°C–	0 to 40°C–	5 to 40°C	0 to 40°C	0 to 40°C
Installation location		Indoor or Outdoor	Indoor or Outdoor–	Indoor or Outdoor	Indoor	Indoor or Outdoor
Ambient temp./humidity		0 to 40°C 85% RH or less	0 to 40°C 85% RH or less	0 to 40°C 90% RH or less	0 to 40°C 85% RH or less	0 to 40°C 85% RH or less
Frequency		50/60Hz	50/60Hz	50/60Hz	50/60Hz	50/60Hz
Suction total head		※1	※1	※2	Within –6m (20°C)	Within –6m (20°C)
Permissible back pressure		0.049~0.2MPa	0.049~0.2MPa	K;(2.7-shutoff pressure) MPa or 0.39MPa KR: (2.7-shutoff pressure) MPa	(0.98-shutoff pressure) MPa	(0.98-shutoff pressure) MPa
Motor	Type	Any	Any	Any	3.7kW or less / TEFC indoor type 2 pole 5.5kW or more / TEFC outdoor type 2 pole	Any
	Power	1.5~110kW	1.5~75kW	5.5~55kW(K) 5.5~90kW(KR)	0.75~7.5KW	0.75~7.5KW
	Phase	3-phase	3-phase	3-phase	Single phase , 3-phase	3-phase
	Voltage	50Hz: 200V 60Hz: 200/220V (Standard)	50Hz: 200V 60Hz: 200/220V (Standard)	50Hz: 200V 60Hz: 200/220V (Standard)	50Hz: 200V 60Hz: 200/220V (Standard)	50Hz: 200V 60Hz: 200/220V (Standard)

- ※ 1 -6m(Bore 40~100mm)
-5.5(Bore 125,150mm)
-4m(Bore 200mm:but suction pipe 250mm)
- ※ 2 Bore 50X40mm; -6m
Bore 65X50; -6m(50Hz), -5.5m(60Hz)
Bore 80X65; -5.5m(50(Hz), -3m(60Hz) , but suction pipe 100mm
Bore 100X80; -3m(50Hz), +1m(60Hz)

[3] Product Configuration

3.1 Structure

The illustration shows the T (TK) type.

With the T-R (TK-R) type, the suction opening is on the right side looking from the motor.

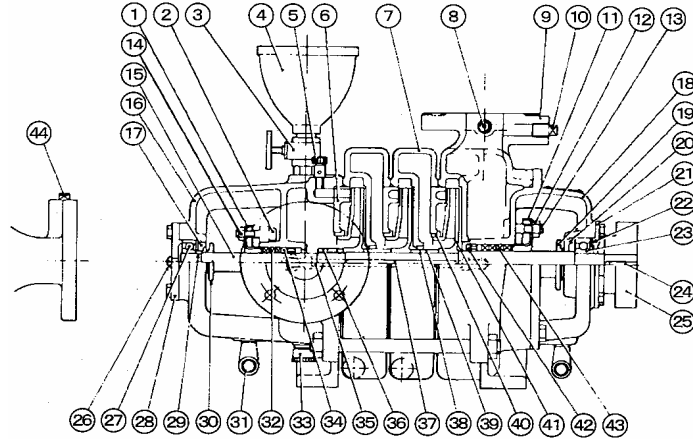

No.	Name	Material	No.	Name	Material	No.	Name	Material
1	Packing retailer	SUS304	16	Suction casing	FC	31	Female/male elbow	FCMB
2	T-bolt	C3604	17	Bearing cover	FC	32	Gland packing	-
3	Stop valve	BC6	18	Casing cover	FC	33	Cap	C3604
4	Priming funnel	Resin (polypropylene)	19	Deflector	Rubber	34	Lantern ring	BC6
5	Exhaust valve	C3604	20	Bearing cover	FC	35	Tube	Resin (nylon)*
6	Partition plate	FC	21	Bearing cover	FC	36	Round nut	BSC2
7	Intermediate casing	FC	22	Wavy washer	SK5	37	Key	SUS403
8	Exhaust valve	C3604	23	Ball-bearing	-	38	Bushing	BC6
9	Discharge casing	FC	24	Key	SUS403	39	Sleeve	BC6
10	Plug	FCMB	25	Shaft coupling	-	40	Liner ring	BC6
11	Packing retailer	SUS304	26	Plug	C3604	41	Impeller	BC6
12	Nut	C3604	27	Ball-bearing	-	42	Lantern ring	BC6
13	Double-end stud	C3604	28	Bearing cover	FC	43	Gland packing	-
14	Nut	C3604	29	Adjusting ring	SS41	44	Plug	FCMB
15	Main shaft	SUS403	30	Deflector	Rubber			

* Straight pipe for TK and TK-R (C1020).

The drawing below represents a typical example of a TN Type Centrifugal Pump and may differ slightly depending on the model.

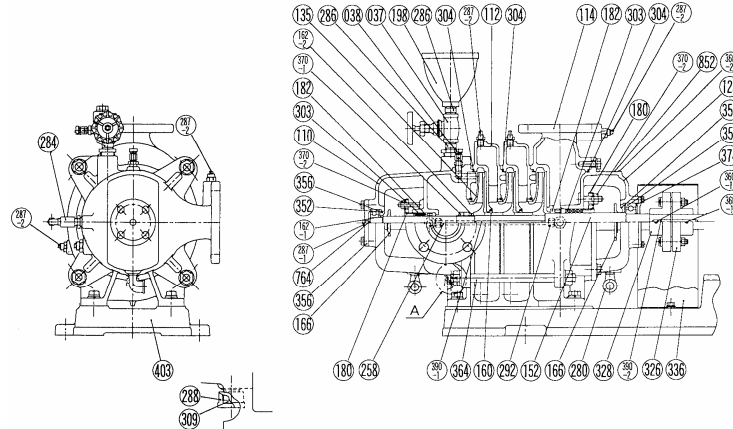

No.	Name	Material	No.	Name	Material
037	Stop valve	BC6	288	Cap	C3604
038	Exhaust valve	-	292	Tube coupling	-
110	Suction casing	FC + Nylon coating	303	Gland packing	-
112	Intermediate casing	FC + Nylon coating	304	O-ring	Rubber (NBR)
114	Discharge casing	FC + Nylon coating	309	Packing	Rubber (NR)
125	Cover with bearing box	FC + Nylon coating	326	Shaft coupling with bolt	-
135	Impeller	BC6	328	Shaft coupling with bushing hole	FC
152	Main shaft	SUS304	336	Shaft coupling guard	SPCC
160	Sleeve	BC6	352	Ball-bearing	SUJ2
162-1	Adjusting ring	SS400	356	Bearing cover	FC
162-2	Adjusting ring	C3604	360-1	Half point set screw	SUS304
166	Deflector	Rubber (NR)	360-2	Driven pin	SUS304
180	Packing retailer	SUS304	364	Double-end stud	SUS403
182	Lantern ring	BC6	370-1	Round nut	C3604
198	Priming funnel	Resin (PP)	370-2	Nut	C3604
258	Tube	Resin (PA)	374	Wavy washer	S65 CM
280	Female/male elbow	FC MB270	390-1	Key	SUS304
284	Female/male socket	C3604	390-2	Key	S45C
286	Nipple	SUS304	403	Base	FC
287-1	Plug	C3604	764	Grease	-
287-2	Plug	SUS13	852	Nameplate	A1100P-H24

The drawing below represents a typical example of a K(R)-M Type Centrifugal Pump and may differ slightly depending on the model.

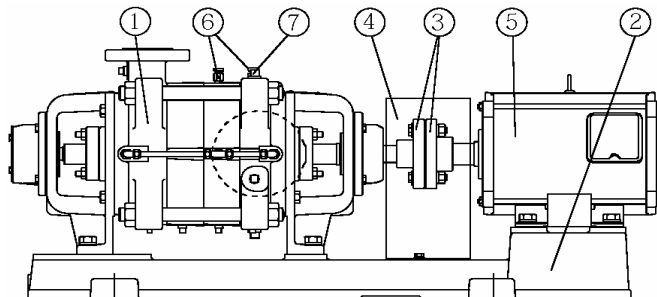

No.	Name
1	Pump
2	Base
3	Shaft coupling
4	Shaft coupling guard
5	Motor
6	Exhaust valve
7	Plug (priming opening)

The drawing below represents a typical example of a KR-C Type Centrifugal Pump and may differ slightly depending on the model.

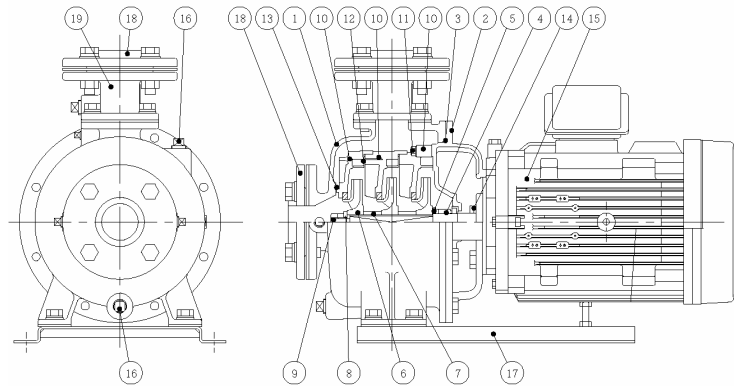

No.	Name	Qty	No.	Name	Qty	No.	Name	Qty
1	Casing	1	8	Flat washer	1	15	Motor	1
2	Casing cover	1	9	Nut	1	16	Plug	2
3	O-ring	1	10	Guide vane	AR	17	Base	1
4	Mechanical seal	1	11	Bolt	3	18	Flange	2
5	Spring stopper	1	12	Partition plate	1	19	Coupling pipe(Excluding KR-65)	1
6	Impeller	AR	13	O-ring	1			
7	Sleeve	AR	14	Deflector	1			

(Note) AR: Differs according to model

The drawing below represents a typical example of a KR4-M Type Centrifugal Pump and may differ slightly depending on the model.

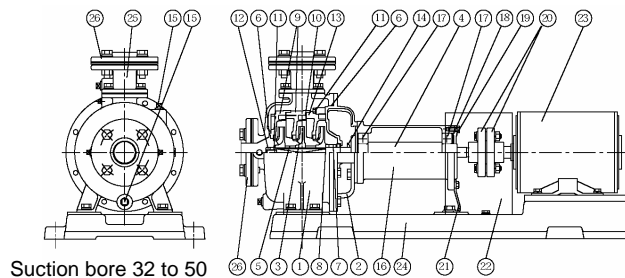

No.	Name	Material	Remarks	No.	Name	Material	Remarks
1	Casing	SCS13	JISG5121	14	Deflector	Rubber (NBR)	
2	Casing cover	SCS13	JISG5121	15	Plug	SCS13	JISG5121
3	Impeller	Resin CAC406 (BC6)	- JISH5120	16	Bearing box	FC150	JISG5501
4	Main shaft	SUS304 (Wetted section)	JISG4305	17	Ball-bearing	-	
5	Sleeve	CAC406 (BC6)	JISH5120	18	Wavy washer	S65CM	JISG3311
6	O-ring	Rubber (NBR)		19	Bearing cover	FC150	JISG5501
7	Mechanical seal	Ceramic×carbon		20	Shaft coupling	-	
8	Spring stopper	SUS304	JISG4305	21	Strainer	SPCC	JISG3141
9	Guide vane	Resin CAC406 (BC6)	- JISH5120	22	Shaft coupling guard	SPCC	JISG3141
10	Partition plate	SUS304	JISG4305	23	Motor	-	
11	Flat washer	SUS304	JISG4305	24	Base	FC150	JISG5501
12	Nut	SUS304	JISG4305	25	Coupling pipe	SCS13	JISG5121
13	Nut	SUS304	JISG4305	26	Flange	SCS13	JISG5121

[4] Installation

⚠ Warning

- Before hoisting the pump unit during unloading, loading, and installation, check the product catalog, the installation drawing, and the instruction manual, etc., to verify the pump unit weight and the hoist method. Do not attempt to hoist a pump unit that exceeds the hoist's rated load. Incorrect hoisting can result in drops and injuries.
- Securely install the pump as explained in the instruction manual. Incomplete installation could result in electric shocks, fires or injuries from dropping.

4.1 Selecting the Installation Place

⚠ Caution

- Do not install the pump that is not waterproof or that has no drainage facility. Major disasters could occur if water leaks.
- Do not install the pump in a highly humid place such as a bathroom. Failure to observe this could result in electric shocks if the earth leakages occur.
- Do not install this pump in places such as machine and chemical factories where toxic gases including acid, alkaline, organic solvents or paint are present, where gases containing corrosive elements are generated, or where there are high levels of dust. Failure to observe this could result in earth leakages or fires.

- (1) Install in a cool, well ventilated location which permits easy disassembly and assembly, and which is not exposed to rain or direct sunlight.
- (2) The installation site's ambient temperature must not exceed 40°C.
- (3) Install in a location which allows easy maintenance and inspection.
- (4) Install the pump as close to the water source as possible, where the suction height (height from suction fluid surface to center of pump) is low, and the horizontal distance of the suction pipe is as short as possible.

4.2

- (1) Insert wedges under the base and install the pump so that it is level. Fix it securely with anchor bolts. (Purchase the anchor bolts separately.)
- (2) Confirm the shaft center
Remove the shaft coupling guard, and turn the shaft coupling by hand to confirm that it turns. If the movement is stiff or uneven, inspect the state. Check that the shaft coupling (shaft center) is not deviated.
If the shaft center is deviated more than shown below, the shaft must be centered.

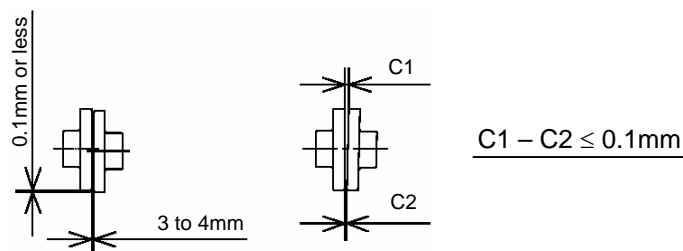

[5] Piping

5.1 Suction Pipe

<Common>

- (1) The pipe should be as short as possible, with no bends.
- (2) A strainer and sand filter should be installed in cases where foreign matter and sand, etc., are likely to be present in the water.

<Suction>: Refer to Fig. 1

- (1) The end of the suction piping must be two or more times deeper than the pipe diameter (D), and separated by 30cm or more from the bottom and walls.
- (2) Attach a foot valve to the end of the suction piping.
- (3) Lay the suction piping with a gradient (1/100 or more) leading upward toward the pump so that air traps do not form.
- (4) Do not install a sluice valve on the suction piping.

< Positive suction, press-in >: Refer to Fig. 2

- (1) Install a sluice valve near the suction opening for maintenance.

5.2 Discharge Pipe

- (1) Install a sluice valve near the discharge opening for maintenance purposes.
- (2) Be sure to install a check valve in cases where the pipe is long, where the actual head is high, where automatic operation occurs, where water is being fed to a pressure tank, and where 2 or more pumps are running in a parallel format. The check valve should be installed between the pump body and the sluice valve.
- (3) A shockless valve, etc., should be installed in cases where there is a risk of water hammer conditions.
- (4) An exhaust valve should be installed in cases where air could trap in the piping.

5.3 Common Items

- (1) Install a vibration proof joint and piping support to prevent the piping weight from being applied directly to the pump.
- (2) Wrap the piping with insulating material to prevent freezing.

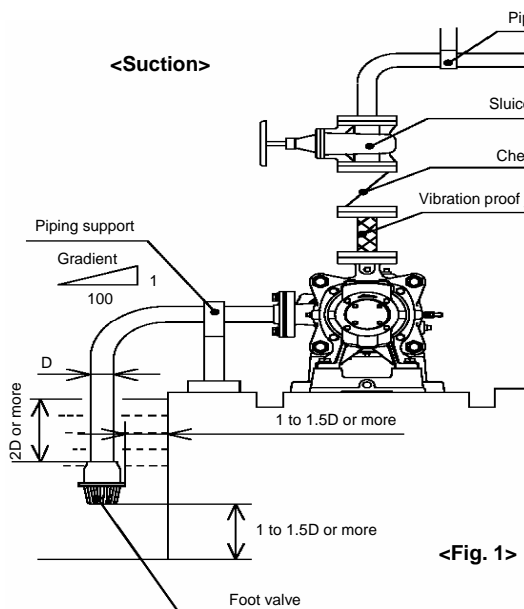

<Fig. 1>

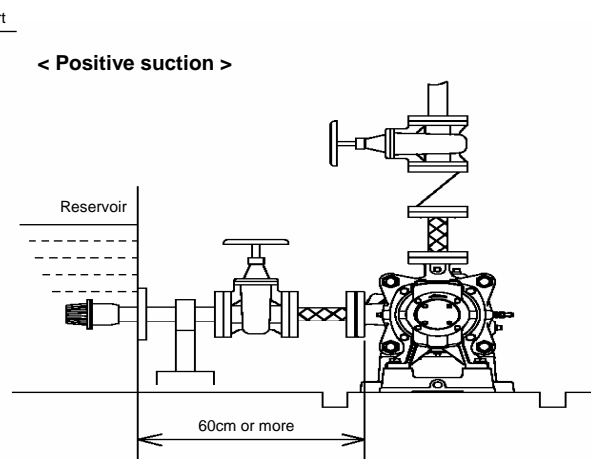

<Fig. 2>

[6] Electrical Work

⚠ Warning

- The electrical work must be completed according to the "Electrical Installation Technical Standards", "Wiring Regulations" and any other applicable regulations. Improper wiring and connections could lead to earth leakages or fires.
- Securely earth the equipment, and install a dedicated residual current circuit breaker. Failure to observe this could result in earth leakages, electric shocks or fires.
- Always earth the pump before turning the power on. Do not connect the earthing wire to gas pipes, water pipes, lightning rods or telephone earthing wires. Failure to earth the equipment correctly could result in electric shocks.

6.1 Power Supply

- (1) Install an residual current circuit breaker at the power supply. Refer to <Fig. 3> or the motor instruction manual and connect the wires to the motor.

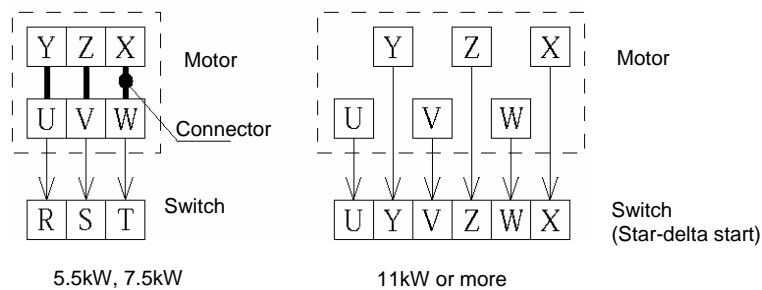

(In cases where there is little margin in the power supply capacity, disconnect the connector, and use a star-delta start.)

<Fig. 3>

6.2 Earth

Perform the necessary earth connection work for the earth terminal in the motor's terminal box. As shown in Fig.4, solder a copper plate that is 30cm square or more or a copper bar that is 1cm thick and 40cm or more long to the end, and then bury 30cm or more under ground in a moist area. Always turn the source power supply OFF when handling the earth wire.

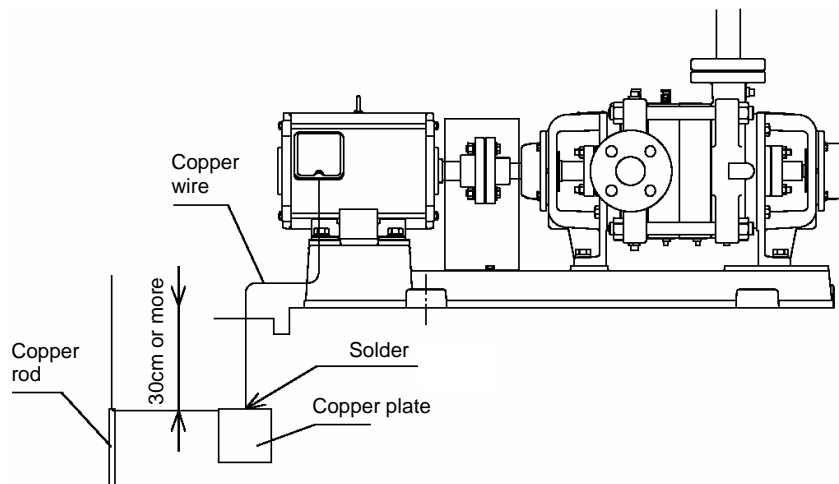

<Fig. 4>

[7] Operation

Warning

- Always turn OFF the power and ensure that no power is being supplied to the pump when attaching or disconnecting wiring. Failure to observe this could result in electric shocks.
- Do not run the pump with the shaft coupling guard removed. The operator could become entangled in the rotating area, possibly resulting in injuries.

Caution

- Do not use this product out of the rated voltage. Failure to observe this could result in fires or electric shocks.
- Verify that the motor is rotating in the prescribed direction. Rotation in the wrong direction can cause water leaks, etc.
- Do not touch the rotating areas during operation, and do not insert fingers or rods, etc., into the motor openings. This could cause electrical shocks and injuries.
- Do not touch the pump or motor during operation. The pump could reach high temperatures and lead to burns.
- Turn OFF the power when not using the pump for long periods of time. Failure to observe this could result in electric shocks, earth leakages, or fires due to deterioration of the insulation.
- Do not run the pump in a dry mode (without water in the pump) or in a shutoff mode (without water inflow to, or discharge from, the pump). Such operations could cause the pump to become extremely hot, possibly resulting in burn injuries.

7.1 Before Operation

- (1) Verify that the residual current circuit breaker capacity, the power supply voltage, and the wiring are correct.
- (2) Confirm the shaft center (P6) again.
- (3) The pump must be primed. Do not perform dry operation, as this can cause a pump failure.
Open the exhaust valve when priming.

<Press-in or positive suction >	: Open the sluice valves at the suction and discharge sides, then prime the pump.
<Suction>	: Remove the plug at the priming opening outlet, and prime the pump while turning the shaft coupling.
- (4) Priming is completed when water is discharged from the exhaust valve. Attach the shaft coupling guard and plug.

7.2 Trial Operation

- (1) After priming the pump, close the sluice valve at the discharge side, and fully open the sluice valve at the suction side.
- (2) Turn the power ON, then turn the switch ON and OFF one or two times to verify the rotation direction (CW direction as viewed from motor side). If 3-phase rotation is reversed, turn the source power supply OFF, then replace the connections of 2 of the 3 wires.
- (3) If the system appears normal, gradually open the sluice valve at the discharge side to establish a continuous operation mode.
Verify that the voltage, current, vibration, and noise conditions, etc., are normal, and verify that there is no leakage from the mechanical seal.

7.3 Stopping Operation

- (1) If there is no check valve at the discharge side, operation should be stopped while gradually closing the discharge side sluice valve.

7.4 Standard Operation

- (1) The pressure gauge cocks, compound gauge cocks, etc. should be closed except when performing measurements. Leaving these cocks open will increase the risk of damage.

7.5 Adjusting the gland packing

⚠ Caution

- A small amount of water should leak from the gland packing direction operation. If the gland packing is too tight, the lubrication will drop, and the main shaft could wear, etc.

- (1) Adjusting the leakage amount
If a large amount of water leaks initially when starting operation, tighten the nut and adjust to an appropriate leakage amount.
The state should stabilize approx. 30 minutes after operation is started, but if a large amount still leaks, tighten again and adjust to the appropriate leakage amount.

- (2) Guide to appropriate leakage amount (ml/min)

Bore	At initial operation	At stable operation	Guide to leakage during stable operation
50	35	12	2 to 3 drops/1 minute
65	40	13	
80	45	15	Almost a straight line of water

[8] Maintenance and Inspection

⚠ Warning

- If the pump does not operate or if an abnormality is sensed (such as a burning smell), stop operation immediately and turn OFF the main power. Then, contact the place of purchase or a designated Kawamoto Pump service center for inspections and repairs. Failure to do so could result in electric shocks, fires, water leaks, etc.
- Always turn the power OFF and make sure that power is not being supplied before starting maintenance servicing. Failure to observe this could result in electric shocks or injuries.

8.1 Daily Inspection

Check Item		Determination Reference
Gland packing		Leakage amount must be appropriate
Mechanical seal		There must be no dripping (leakage) from the seal.
Motor	Surface temperature	Ambient temperature + 75°C or less
	Ball-bearing	There must be no abnormal operation noise or vibration
Pressure		No increase from the normal pressure.
Current		Nameplate rated current value or less.
Voltage		Within ±10% of rated voltage

Daily inspections are essential for detecting problems quickly. The maintenance of a daily operation log is therefore recommended.

8.2 Consumable parts

The following parts are consumable parts. Refer to the replacement guidelines and replace the parts.

Part name	Replacement guideline	Guide to state
Gland packing	1 year	When large amount of water leaks even after tightening
Mechanical seal	2 years	When water leaks
Ball-bearing	3 years	When bearings become hot, or when abnormal noise or vibration occurs

[9] Disassembly and Assembly

Warning

- This product must never be disassembled, repaired or modified by any person other than a qualified repair technician. Improper repairs could lead to electric shocks, fires or water leaks.
- When desiring to reinstall the pump in a new location, please contact your dealer or designated service center for assistance. Improper installation could lead to electric shocks, fires or water leaks.

[10] Troubleshooting

Problem	Cause	Countermeasure	Manual page No.
Motor does not operate	Power supply problem.	Inspect and repair.	8
Pump rotates, but no water is discharged. Prescribed discharge amount/pressure is not obtained.	Sluice valve is closed.	Open the sluice valve.	9
	The pump is insufficiently primed.	Prime, and fill the pump with water.	9
	The suction pipe does not reach the water	Extend the suction pipe so it is submerged in the water	7
	Pump rotation direction is reversed.	Correct the wiring.	8
	Worn parts.	Replace the worn parts.	10, 11
Overload (over-current) occurs	Voltage drop, or unbalanced phase conditions exist.	Check the power supply.	8
Pump vibrates/abnormal noise	Improper installation.	Check the installation condition.	6
	Pump rotation direction is reversed.	Correct the wiring.	8
	Shaft center deviation.	Perform a centering procedure.	6

Unexpected trouble could occur. However, it is important to take appropriate measures immediately when an abnormal condition is found. If the cause of the trouble is not clear, contact your dealer or designated service center. Notice the pump type, serial No. and trouble (fault) state making an inquiry.

Kawamoto Pump Mfg.Co.,Ltd.

Head office: 4-11, Ohsu Naka-ku Nagoya, 460-8650 Japan

No.	87100832
-----	----------