

VU4

KAWAMOTO SUBMERSIBLE PUMP

4 POLES / 50 Hz

SIZE 50 ~ 100 MM.

100% SOLID PASSAGE MODEL



VORTEX IMPELLER



APPLICATIONS AND FEATURES

■ APPLICATIONS

- For discharge of sewage and wastewater.

■ FEATURES

- Excellent ability for pass foreign object without entangling (can discharge spherical solids with a diameter which equals to the bore size).
- Our original casing structure (patented) provided excellent pumping performance.
- Equipped with a motor with built-in auto-cut (7.5kW or less) to prevent motor burnout.
- Motor with output of 11kW or above can detect abnormal temperature rise of the motor coil as an external signal.
- Two types available: flange type and pedestal support type for easy maintenance and inspection.

Some models with output of 3.7kW or less are available with a float switch (automatic, auto alternate built-in).

STANDARD SPECIFICATIONS

Description		Model : VU4
Applicable Liquid		Waste water, filthy water and other miscellaneous dirty water
Liquid Temperature		0-40 °C
pH		5-9
Main Pump	Casing	Cast Iron
	Impeller	Cast Iron (FCD : 11kW)
	Shaft	Stainless Steel (SUS420J2)
Motor	Speed	1500 rpm
	Protection	IP68, Class F
Construction	Impeller	Vortex
	Shaft Seal	Double mechanical seal Pump : Sic x Sic Motor : Ceramics x Carbon
	Motor Bearing	Sealed ball bearing
Maximum Submergence		0.75 kW : 5m. 1.5-15 kW : 8 m.

OPTIONAL SPECIFICATIONS

Description		Model : VU4
Applicable Liquid		Waste water, filthy water and other miscellaneous dirty water
Liquid Temperature		0-60 °C
pH		5-9
Main Pump	Casing	Cast Iron
	Impeller	SCS13
	Shaft	Stainless Steel (SUS420J2)
Motor	Speed	1500 rpm
	Protection	IP68, Class F
Construction	Impeller	SCS13 100% solid passage impeller (0.75-15kW)
	Shaft Seal Oil	Double mechanical seal Pump : Sic x Sic Motor : Ceramics x Carbon White oil
	Motor Bearing	Sealed ball bearing
Cable length(m)		10m, 20m, 30m

SOLID PASSAGE

Pump Bore (mm)	Solid diameter (mm)	Clothes (mm)
50	50	Less than 400mm
65	65	
80	80	
100	100	

CABLE

Output (kW)	Phase	Size (mm ²)	Core	Outer diameter (mm)	Length (m)
0.75	3	1.25	4	11	6
1.5	3	1.25	4	11	10
2.2	3	1.25	4	11	10
3.7	3	2	4	11.7	10
5.5	3	3.5	4	13.8	10
7.5	3	5.5	4	16.5	10
11	3	3.5 x 2	4+3	13.8	10 x 2
15	3	5.5 x 2	4+3	16.5	10 x 2

Cable Material : 600V insulating (VCT)

PERFORMANCE CHART

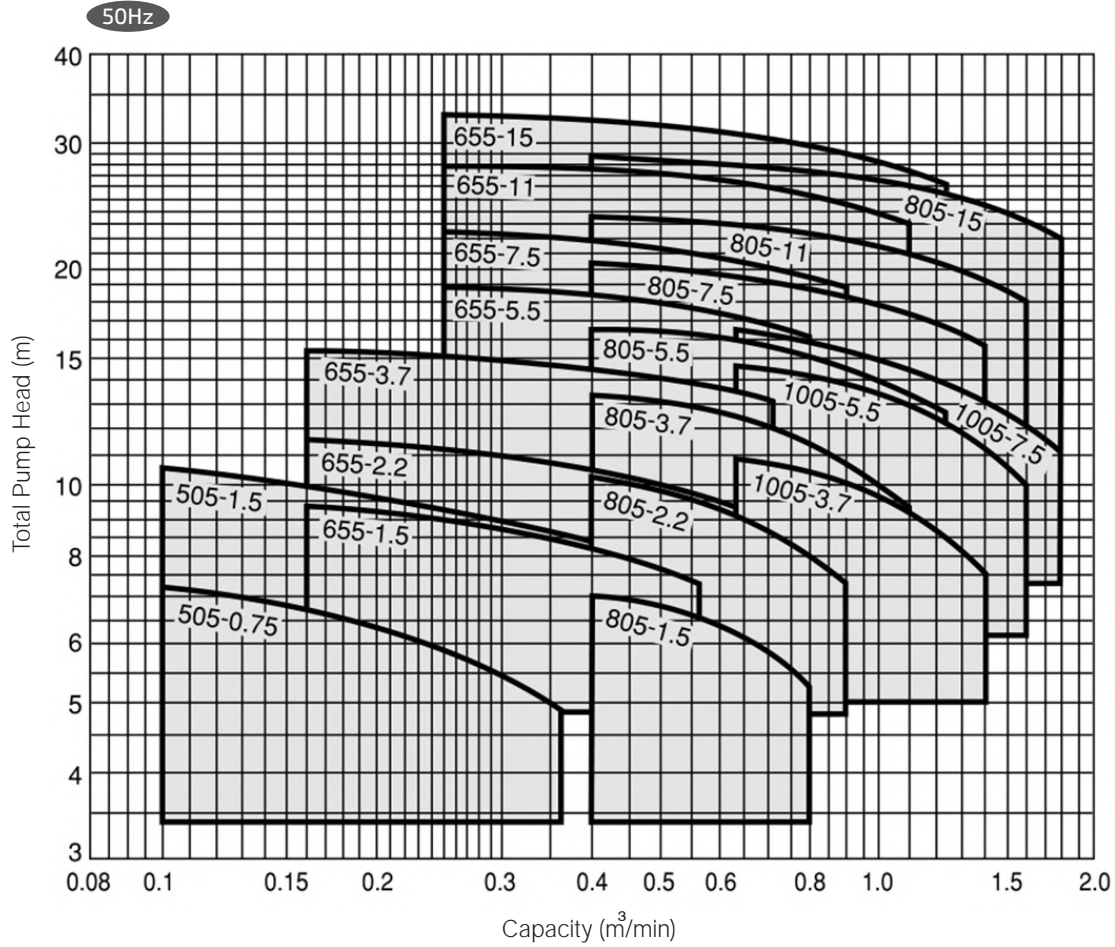

MODEL CODE

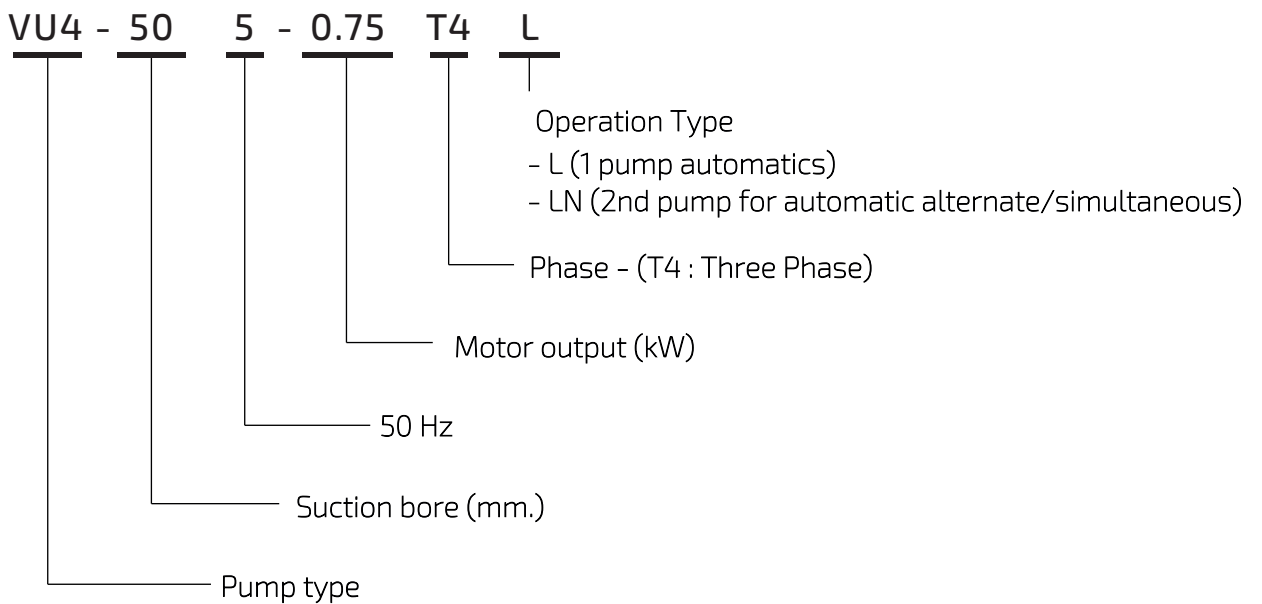

PUMP DATA - VU4

No.	Bore (mm)	Motor		Model	Performance			
		kW	Phase		Capacity (m ³ /min)	Total Head (m)	Capacity (m ³ /min)	Total Head (m)
1	50	0.75	3	VU4-505-0.75T4	0.1	7.2	0.36	4.8
2		1.5	3	VU4-505-1.5T4	0.1	10.5	0.4	8.2
3	65	1.5	3	VU4-655-1.5T4	0.16	9.2	0.56	7.2
4		2.2	3	VU4-655-2.2T4	0.16	11.5	0.63	9.2
5		3.7	3	VU4-655-3.7T4	0.16	15.2	0.71	13
6		5.5	3	VU4-655-5.5T4	0.25	18.8	0.8	16
7		7.5	3	VU4-655-7.5T4	0.25	22.5	0.9	18.8
8		11	3	VU4-655-11T4	0.25	28	1.1	23
9		15	3	VU4-655-15T4	0.25	32.5	1.25	26
10	80	1.5	3	VU4-805-1.5T4	0.4	7	0.8	5.2
11		2.2	3	VU4-805-2.2T4	0.4	10.2	0.9	7.2
12		3.7	3	VU4-805-3.7T4	0.4	13.2	1.1	9.2
13		5.5	3	VU4-805-5.5T4	0.4	16.5	1.25	12.5
14		7.5	3	VU4-805-7.5T4	0.4	20.2	1.4	15.5
15		11	3	VU4-805-11T4	0.4	23.5	1.6	18
16	15	3	VU4-805-15T4	0.4	28.5	1.8	22	
17	100	3.7	3	VU4-1005-3.7T4	0.63	10.8	1.4	7.5
18		5.5	3	VU4-1005-5.5T4	0.63	14.5	1.6	9.8
19		7.5	3	VU4-1005-7.5T4	0.63	16.2	1.8	11
1	50	0.75	3	VU4-505-0.75T4(L/LN)	0.1	7.2	0.36	4.8
2		1.5	3	VU4-505-1.5T4(L/LN)	0.1	10.5	0.4	8.2
3	65	1.5	3	VU4-655-1.5T4(L/LN)	0.16	9.2	0.56	7.2
4		2.2	3	VU4-655-2.2T4(L/LN)	0.16	11.5	0.63	9.2
5		3.7	3	VU4-655-3.7T4(L/LN)	0.16	15.2	0.71	13
10	80	1.5	3	VU4-805-1.5T4(L/LN)	0.4	7	0.8	5.2
11		2.2	3	VU4-805-2.2T4(L/LN)	0.4	10.2	0.9	7.2
12		3.7	3	VU4-805-3.7T4(L/LN)	0.4	13.2	1.1	9.2
17	100	3.7	3	VU4-1005-3.7T4(L/LN)	0.63	10.8	1.4	7.5

SECTION VIEW - FLANGE TYPE

VU4

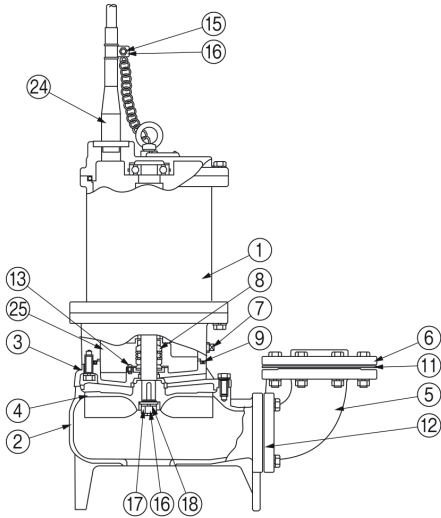

VU4-L

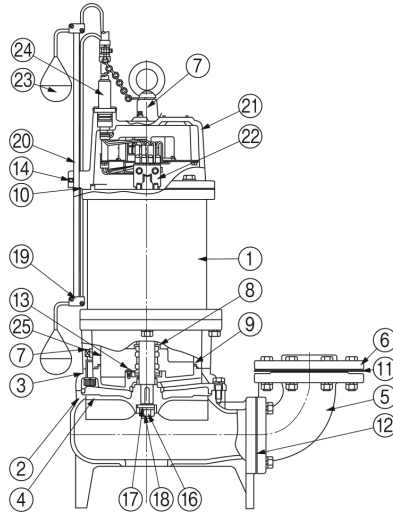

VU4-LN

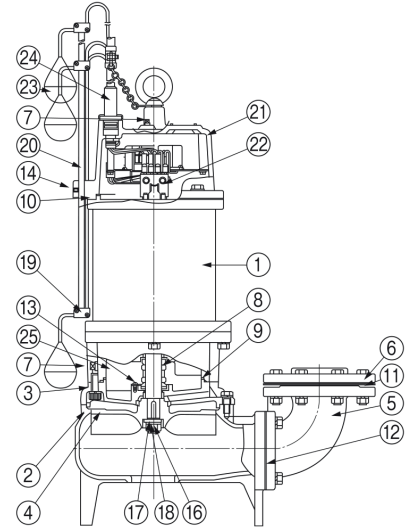

No.	Part name	Material	Note	No.	Part name	Material	Note
1	Motor	-	Class F	14	Screw	SUS304	
2	Casing	Cast iron		15	Bolt	SUS304	
3	Casing cover	Cast iron		16	Nut	SUS304	
4	Impeller	Cast iron		17	Plane washer	SUS304	
5	Bend	Cast iron		18	Spring washer	SUS304	
6	Flange	Cast iron		19	Clamp	Resin	
7	Plug	SCS13		20	Rode	Resin	
8	Mechanical seal	-		21	Motor cover	Cast iron	
9	O-Ring	Rubber		22	Magnetic switch	-	
10	Packing	Rubber		23	Float switch	-	
11	Flange packing	Rubber		24	Cable	VCT	
12	Flange packing	Paper		25	Turbine oil	VG32	
13	Screw	SWRM10		※Shaft : SUS420J2			

SECTION VIEW - WITH Q.D.C TYPE

VU4

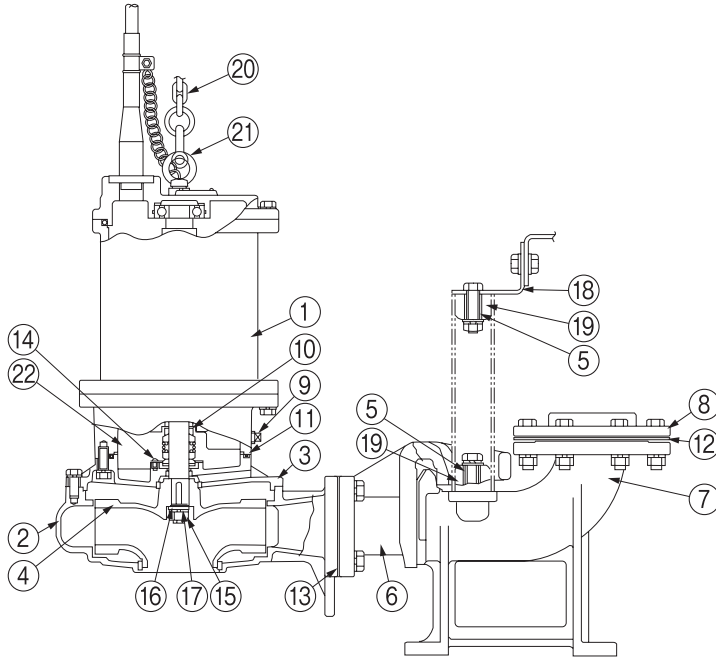

No.	Part name	Material	Note
1	Motor	-	Class F
2	Casing	Cast iron	
3	Casing cover	Cast iron	
4	Impeller	Cast iron	
5	Pipe	SUS304-TP	
6	Connecting pipe	FCD	
7	Connecting bend with baseplate	Cast iron	
8	Flange	Cast iron	
9	Plug	SCS13	
10	Mechanical seal	-	
11	O-Ring	Rubber	
12	Flange packing	Rubber	
13	Flange packing	Paper	
14	Screw	SWRM10	
15	Nut	SUS304	
16	Plane washer	SUS304	
17	Spring washer	SUS304	
18	Supporter	SUS304-TP	
19	Cushion	Rubber	
20	Chain	Steel	
21	Shackle	Steel	
22	Turbine oil	VG32	

※Shaft : SUS420J2

FLANGE DIMENSION

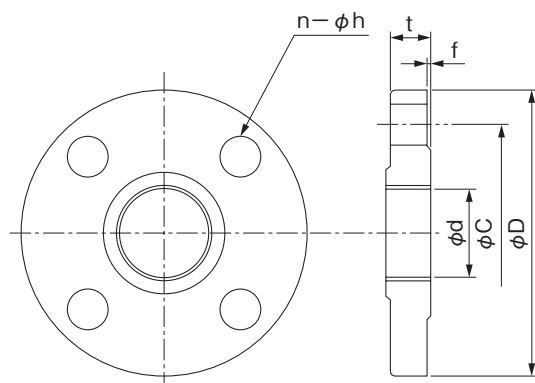

Unit:mm

Bore a	d	C	D	t	f	n	h (Bolt)
50	Rc2	120	155	18	2	4	15(M12)
65	Rc2 ½	140	175	18	2	4	15(M12)
80	Rc3	150	185	18	2	8	15(M12)
100	Rc4	175	210	20	2	8	15(M12)

PUMP DIMENSION - VU4 WITH FLANGE TYPE

VU4

VU4-L

VU4-LN

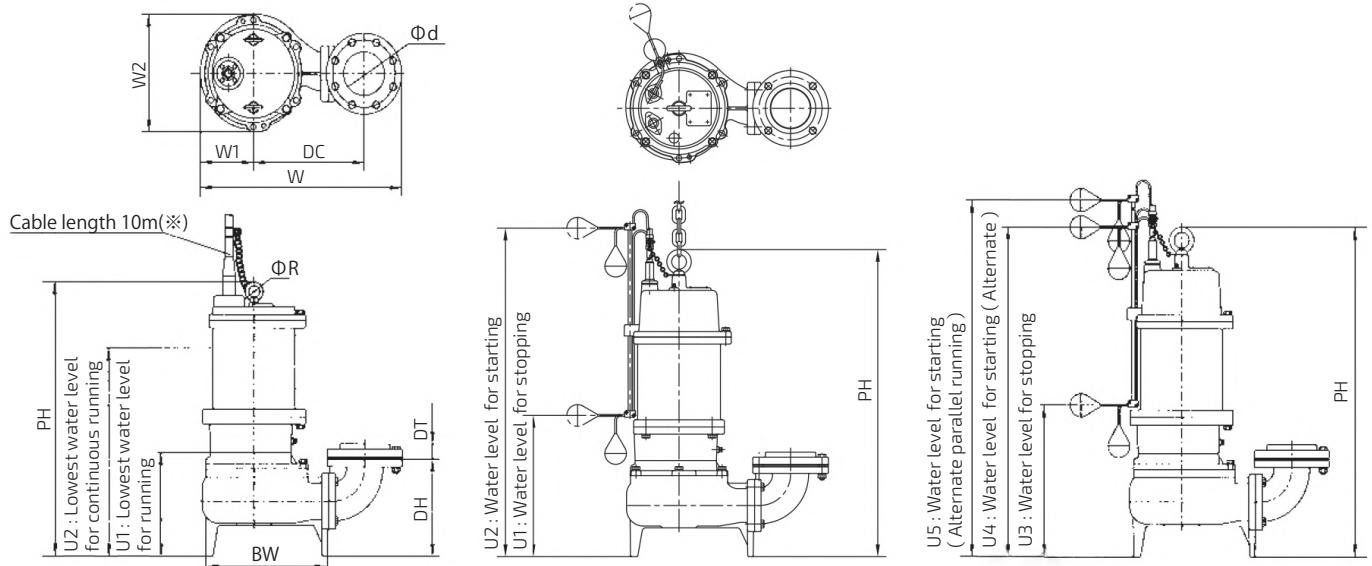

※ 6m when it's less than 0.75kW

Discharge Bore (mm)	Model	Motor (kW)	Pump Combination								Water Level					Other		Weight (kg)
			PH	DH	DT	BW	W	W1	W2	DC	U1	U2	U3	U4	U5	RW	R	
50	VU4-50S-0.75T4	0.75	563	198	27	221	387	104	232	195	189	389	-	-	-	-	25	42
	VU4-50S-1.5T4	1.5	563	198	27	261	425	122	262	215	189	389	-	-	-	-	25	48
65	VU4-65S-1.5T4	1.5	598	231	31	276	461	123	262	245	210	426	-	-	-	-	25	56
	VU4-65S-2.2T4	2.2	664	231	31	276	461	123	262	245	210	481	-	-	-	-	30	73
	VU4-65S-3.7T4	3.7	671	231	31	277	500	147	296	265	210	481	-	-	-	-	30	82
	VU4-65S-5.5T4	5.5	677	231	31	321	548	165	332	295	210	508	-	-	-	-	30	111
	VU4-65S-7.5T4	7.5	677	231	31	321	548	165	332	295	210	508	-	-	-	-	30	117
	VU4-65S-11T4	11	755	256	31	416	634	189	386	340	230	565	-	-	-	-	30	163
	VU4-65S-15T4	15	815	256	31	416	634	189	386	340	230	610	-	-	-	-	30	212
80	VU4-80S-1.5T4	1.5	627	262	33	246	464	109	232	250	240	460	-	-	-	-	25	55
	VU4-80S-2.2T4	2.2	693	262	33	286	507	132	267	270	240	510	-	-	-	-	30	74
	VU4-80S-3.7T4	3.7	693	262	33	286	507	132	267	270	240	510	-	-	-	-	30	79
	VU4-80S-5.5T4	5.5	706	262	33	341	563	148	304	310	240	537	-	-	-	-	30	110
	VU4-80S-7.5T4	7.5	706	262	33	381	601	166	336	330	240	537	-	-	-	-	30	120
	VU4-80S-11T4	11	770	263	33	416	630	185	384	340	245	580	-	-	-	-	30	167
	VU4-80S-15T4	15	830	263	33	416	630	185	384	340	245	625	-	-	-	-	30	216
100	VU4-100S-3.7T4	3.7	732	299	39	316	526	131	266	290	276	547	-	-	-	-	30	81
	VU4-100S-5.5T4	5.5	745	301	39	304	570	155	311	310	280	576	-	-	-	-	30	114
	VU4-100S-7.5T4	7.5	745	301	39	304	570	155	311	310	280	576	-	-	-	-	30	120
50	VU4-50S-0.75T4(L/LN)	0.75	613	198	27	221	387	1054	232	195	232	632	292	572	692	245	25	44
	VU4-50S-1.5T4(L/LN)	1.5	613	198	27	261	425	122	262	215	232	632	292	572	692	245	25	50
65	VU4-65S-1.5T4(L/LN)	1.5	648	231	31	276	461	123	262	245	269	669	329	609	729	245	25	58
	VU4-65S-2.2T4(L/LN)	2.2	719	231	31	276	461	123	262	245	253	803	323	733	873	245	30	75
	VU4-65S-3.7T4(L/LN)	3.7	726	231	31	277	500	147	296	265	253	803	323	733	873	245	30	84
80	VU4-80S-1.5T4(L/LN)	1.5	677	262	33	246	464	109	232	250	298	698	358	638	758	245	25	57
	VU4-80S-2.2T4(L/LN)	2.2	748	262	33	286	507	132	267	270	282	832	352	762	902	245	30	76
	VU4-80S-3.7T4(L/LN)	3.7	748	262	33	286	507	132	267	270	282	832	352	762	902	245	30	81
100	VU4-100S-3.7T4(L/LN)	3.7	787	299	39	316	526	131	266	290	319	869	389	799	939	245	30	83

PUMP DIMENSION - VU4 WITH Q.D.C TYPE

VU4

VU4-L

VU4-LN

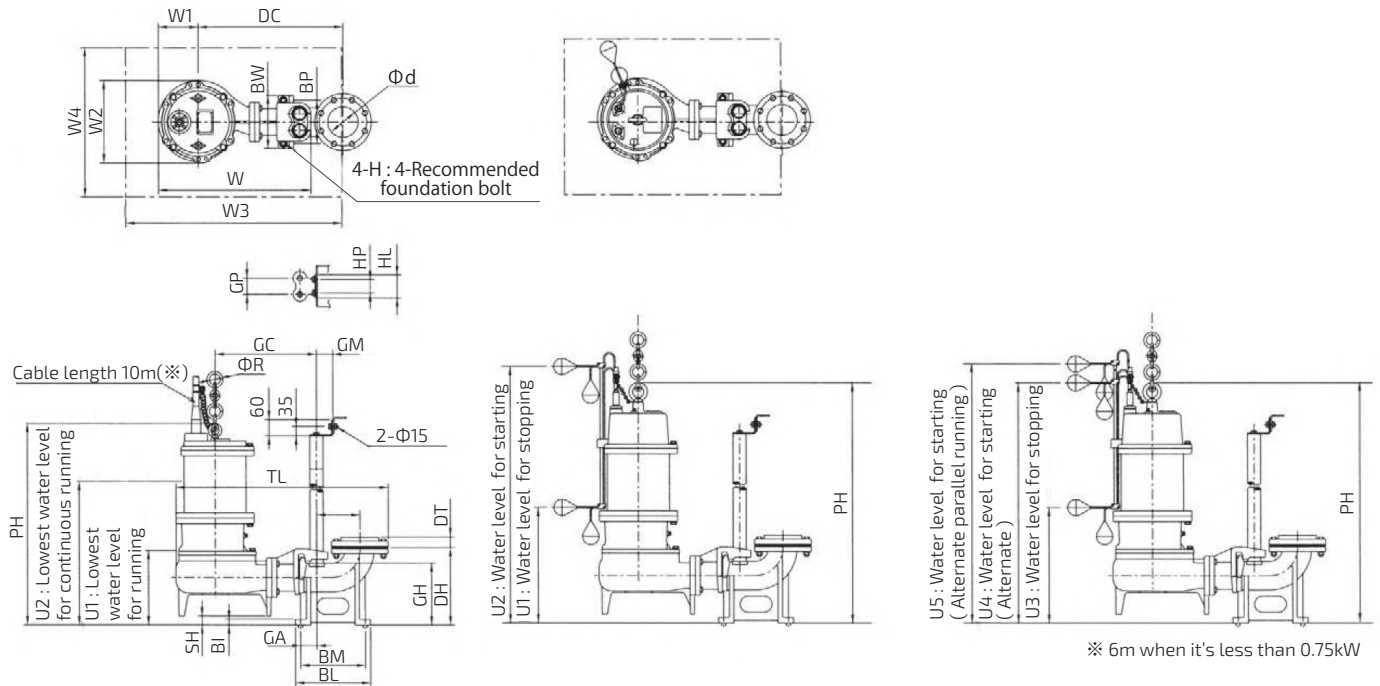

Discharge Bore (mm)	Model	Motor (kW)	Pump Combination								Water Level					Other		Weight (kg)
			PH	SH	DC	TL	W	W1	W2	GC	U1	U2	U3	U4	U5	RW	R	
50	VU4-50S-0.75T4	0.75	590	27	395	587	405	104	232	265	216	416	-	-	-	-	25	42
	VU4-50S-1.5T4	1.5	590	27	415	625	443	122	262	285	216	416	-	-	-	-	25	48
65	VU4-65S-1.5T4	1.5	627	29	465	680	488	123	262	345	239	455	-	-	-	-	30	56
	VU4-65S-2.2T4	2.2	693	29	465	680	488	123	262	345	239	510	-	-	-	-	30	73
	VU4-65S-3.7T4	3.7	700	29	485	724	533	147	296	345	239	510	-	-	-	-	30	82
	VU4-65S-5.5T4	5.5	706	29	515	772	581	165	332	375	239	537	-	-	-	-	30	111
	VU4-65S-7.5T4	7.5	706	29	515	772	581	165	332	375	239	537	-	-	-	-	30	117
	VU4-65S-11T4	11	794	39	555	849	625	189	386	395	270	595	-	-	-	-	30	163
	VU4-65S-15T4	15	854	39	555	849	625	189	386	395	270	640	-	-	-	-	30	212
80	VU4-80S-1.5T4	1.5	660	33	465	697	496	109	232	305	273	493	-	-	-	-	25	55
	VU4-80S-2.2T4	2.2	726	33	485	719	498	132	267	325	273	543	-	-	-	-	30	74
	VU4-80S-3.7T4	3.7	726	33	485	719	498	132	267	325	273	543	-	-	-	-	30	79
	VU4-80S-5.5T4	5.5	739	33	525	778	554	148	304	365	273	570	-	-	-	-	30	110
	VU4-80S-7.5T4	7.5	739	33	545	816	592	166	336	385	273	570	-	-	-	-	30	120
	VU4-80S-11T4	11	802	32	555	845	621	185	384	395	280	600	-	-	-	-	30	167
100	VU4-100S-3.7T4	3.7	761	29	575	791	545	131	266	365	305	576	-	-	-	-	30	81
	VU4-100S-5.5T4	5.5	77	29	575	835	590	155	311	385	309	605	-	-	-	-	30	114
	VU4-100S-7.5T4	7.5	774	29	575	835	590	155	311	385	309	605	-	-	-	-	30	120
50	VU4-50S-0.75T4(L/LN)	0.75	640	27	395	587	405	104	232	265	259	659	319	599	719	245	25	44
	VU4-50S-1.5T4(L/LN)	1.5	640	27	415	625	443	122	262	285	259	659	319	599	719	245	25	50
65	VU4-65S-1.5T4(L/LN)	1.5	677	29	465	680	488	123	262	345	298	698	358	638	758	245	25	58
	VU4-65S-2.2T4(L/LN)	2.2	748	29	465	680	488	123	262	345	282	832	352	762	902	245	30	75
	VU4-65S-3.7T4(L/LN)	3.7	755	29	485	724	533	147	296	345	282	832	352	762	902	245	30	84
80	VU4-80S-1.5T4(L/LN)	1.5	710	33	465	679	455	109	232	305	331	731	391	671	791	245	25	57
	VU4-80S-2.2T4(L/LN)	2.2	781	33	485	719	498	132	267	325	315	865	385	795	935	245	30	76
	VU4-80S-3.7T4(L/LN)	3.7	781	33	485	719	498	132	267	325	315	865	385	795	935	245	30	81
100	VU4-100S-3.7T4(L/LN)	3.7	816	29	575	791	545	131	266	365	348	898	418	828	968	245	30	83

EXPECTED PERFORMANCE CURVE

MODEL : VU4-505-0.75T4

■ PERFORMANCE CURVES

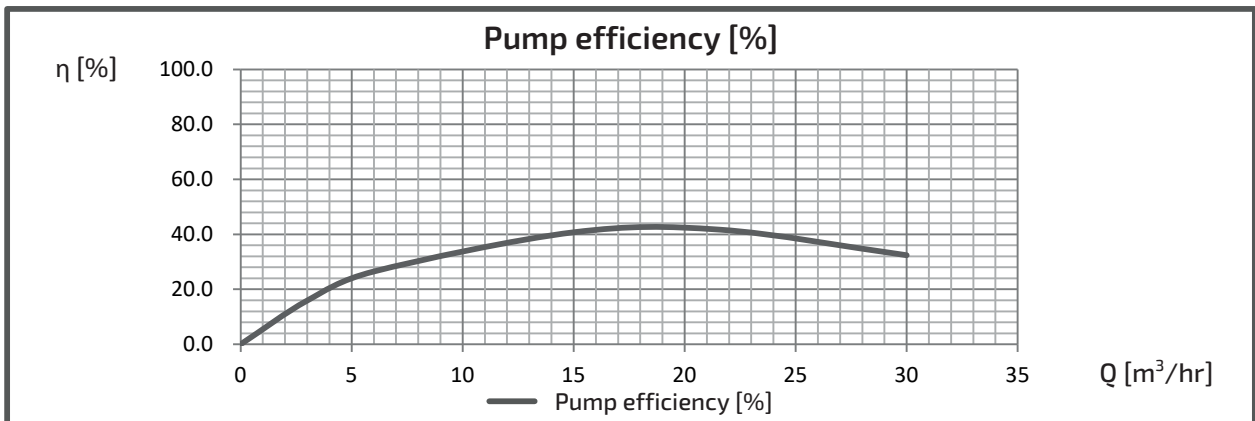
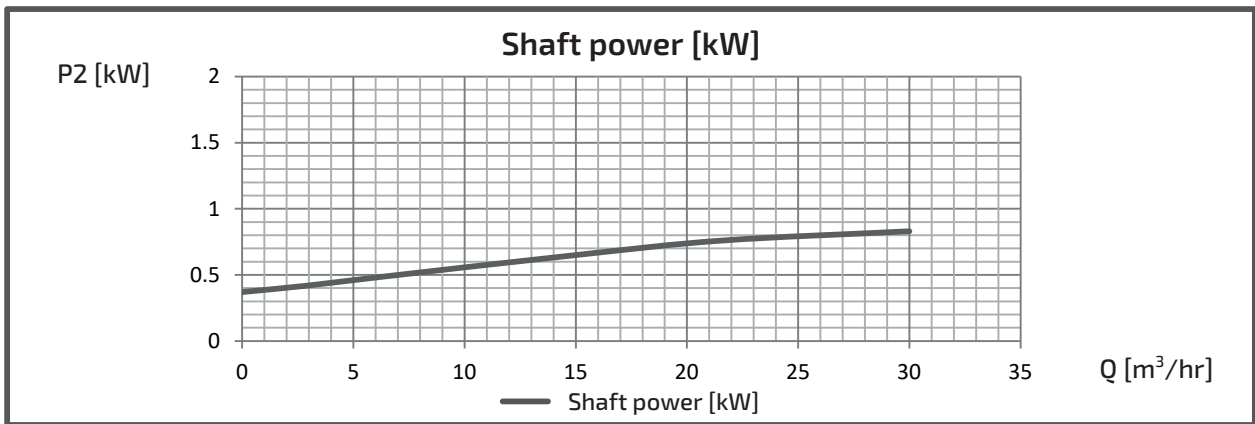
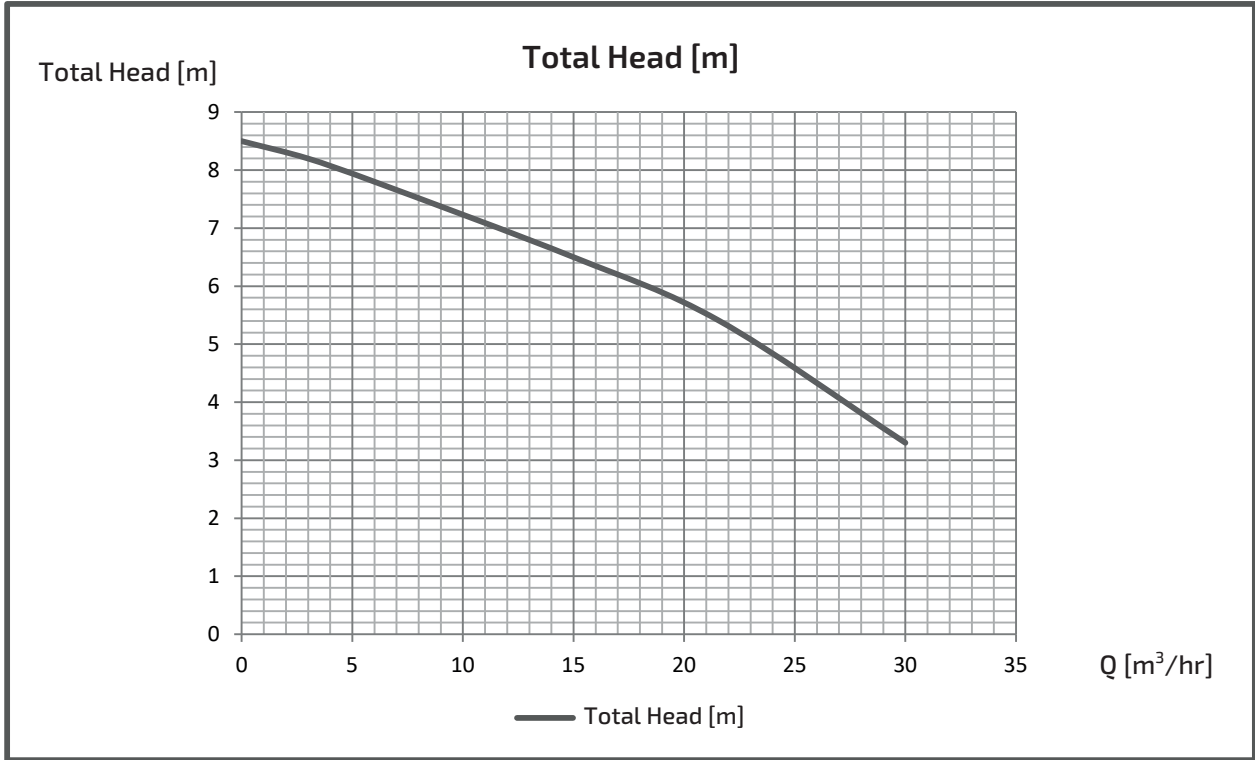

EXPECTED PERFORMANCE CURVE

MODEL : VU4-505-1.5T4

■ PERFORMANCE CURVES

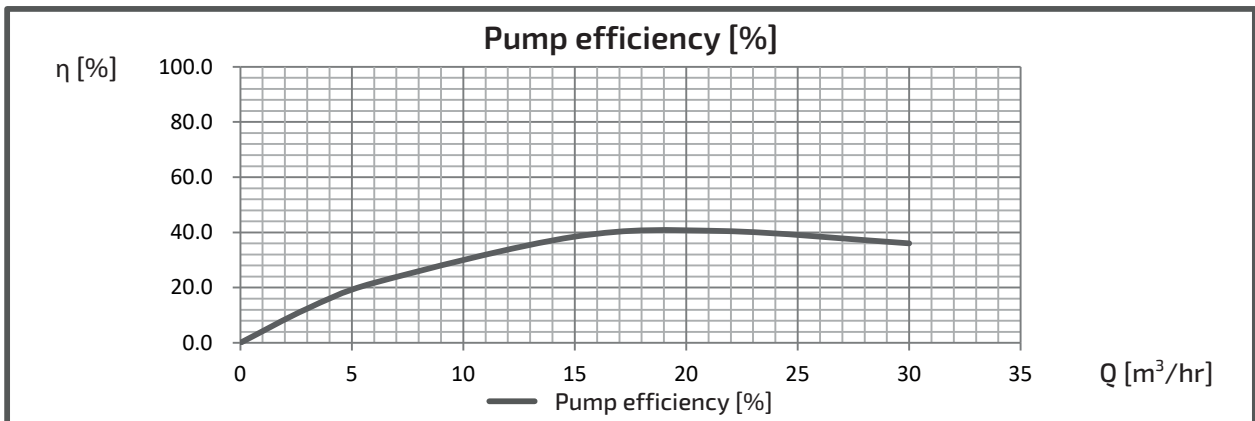
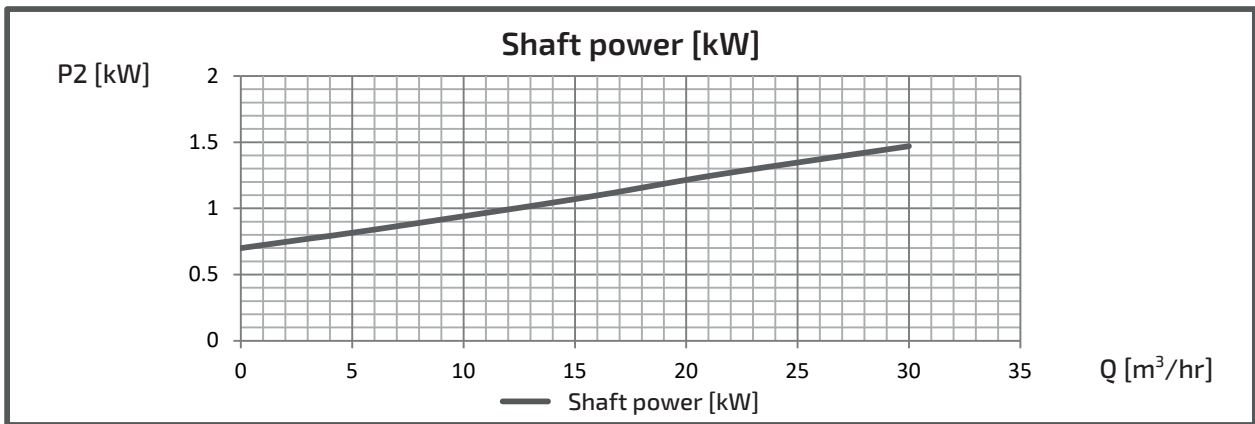
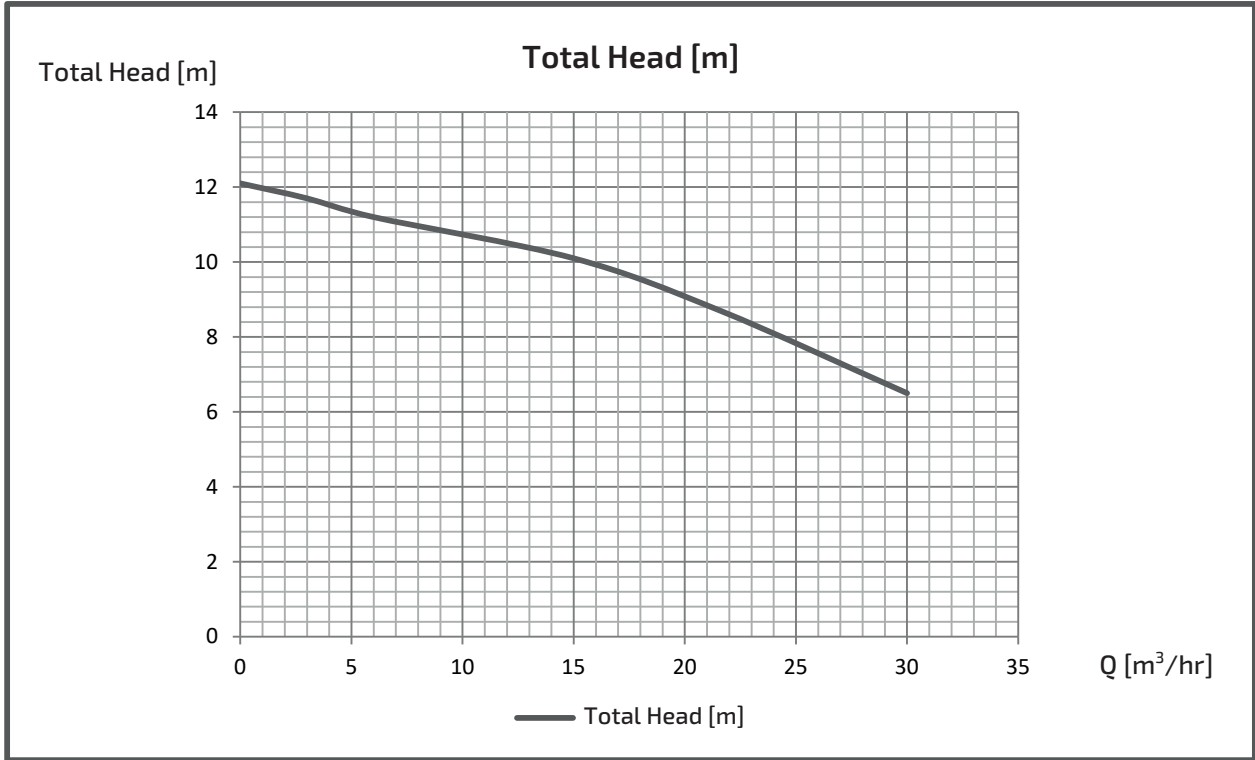

EXPECTED PERFORMANCE CURVE

MODEL : VU4-655-1.5T4

■ PERFORMANCE CURVES

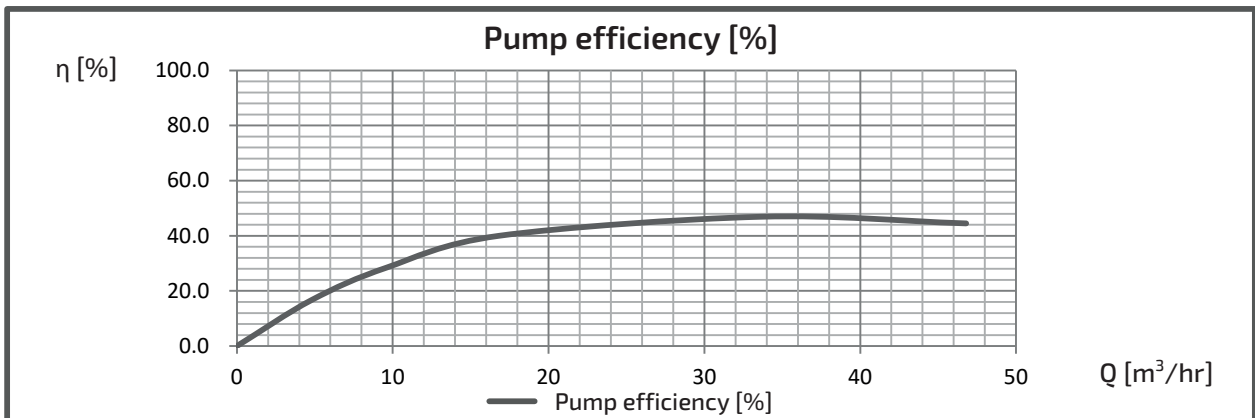
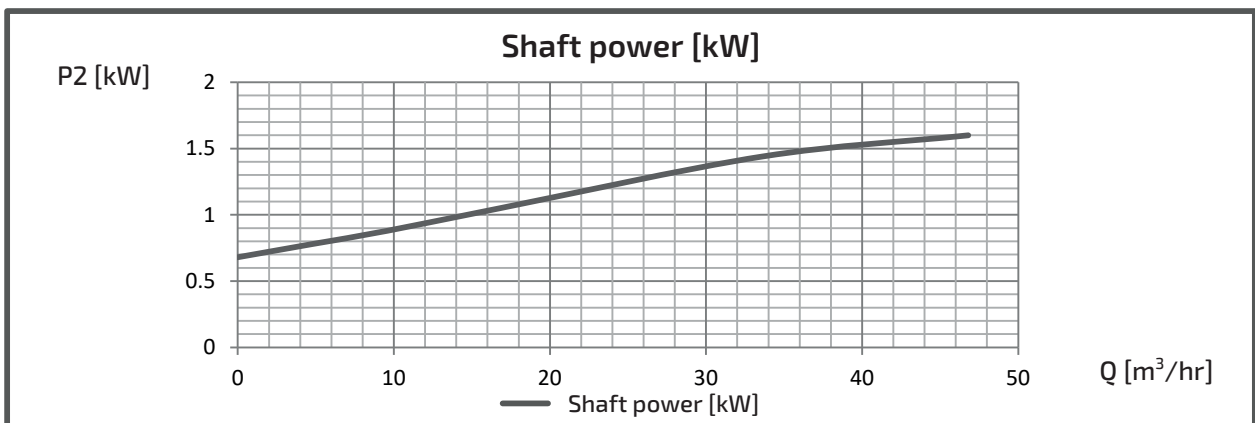
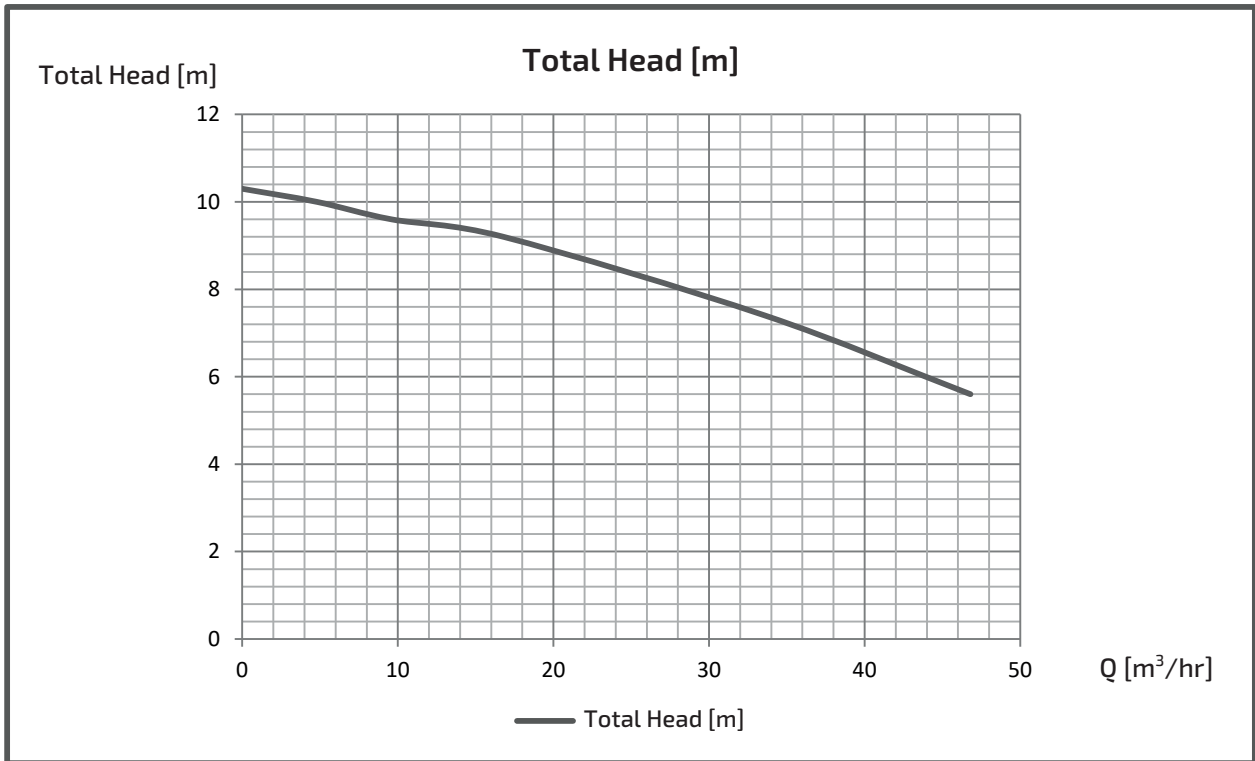

EXPECTED PERFORMANCE CURVE

MODEL : VU4-655-2.2T4

■ PERFORMANCE CURVES

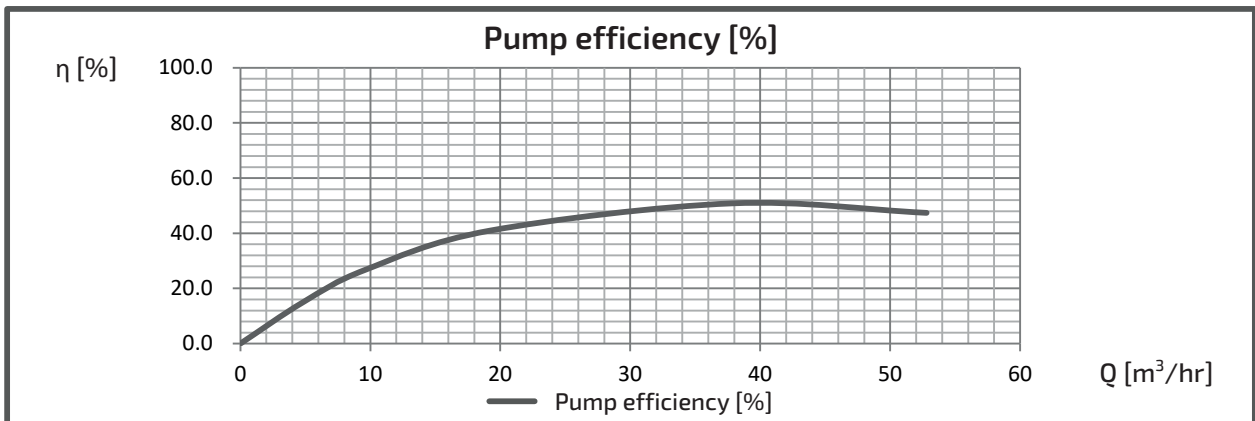
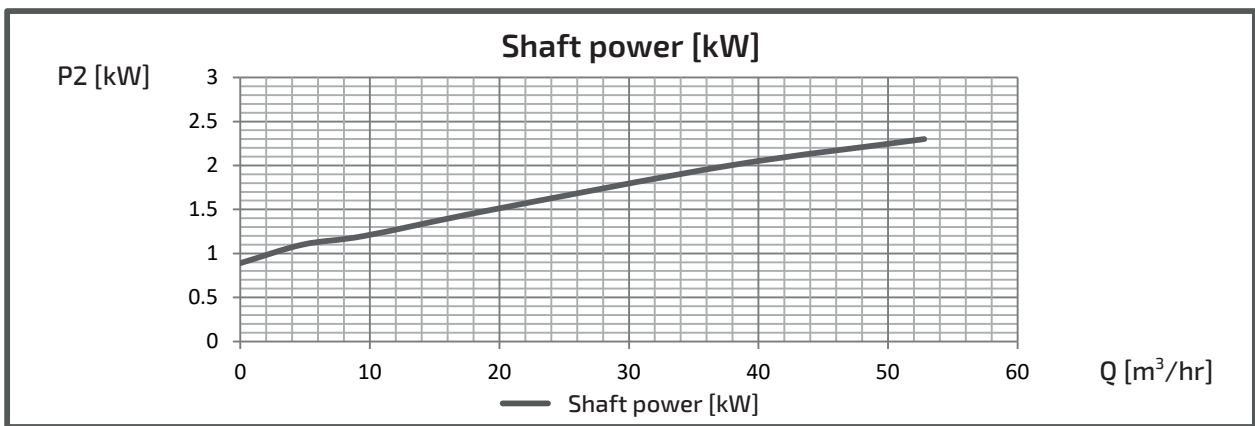
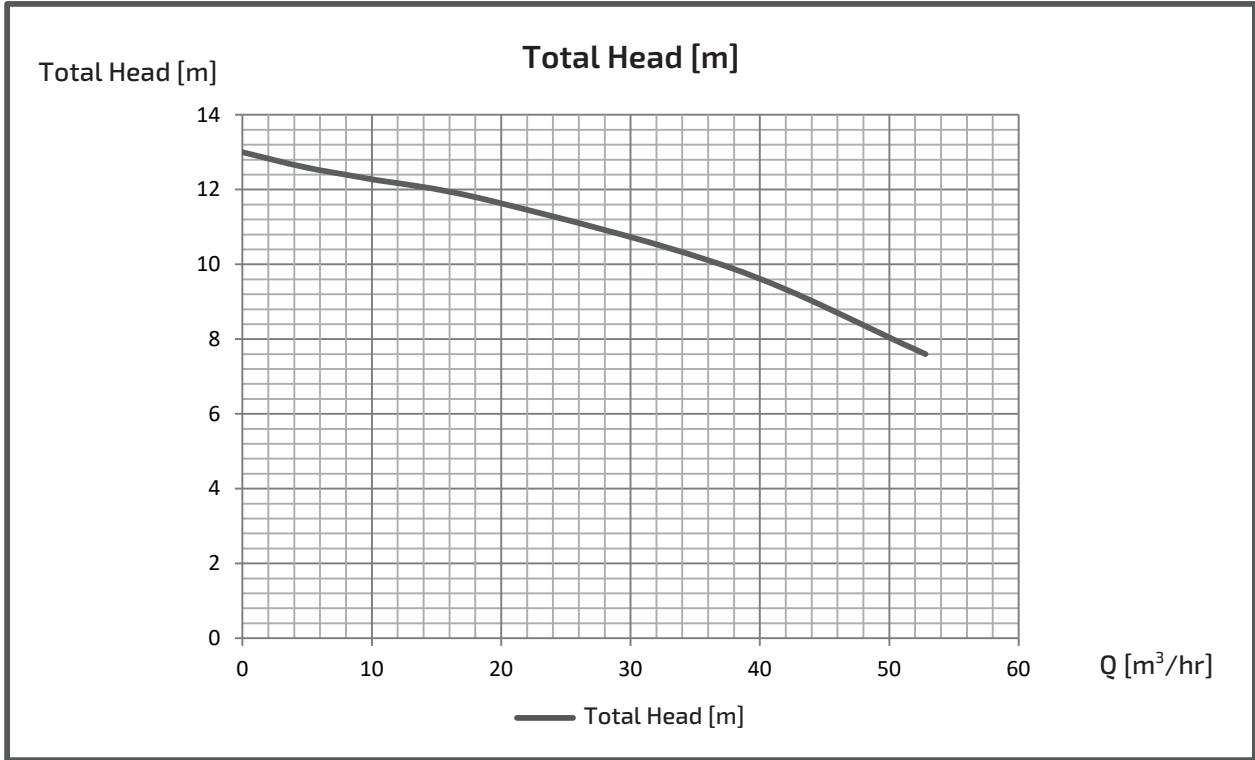

EXPECTED PERFORMANCE CURVE

MODEL : VU4-655-3.7T4

■ PERFORMANCE CURVES

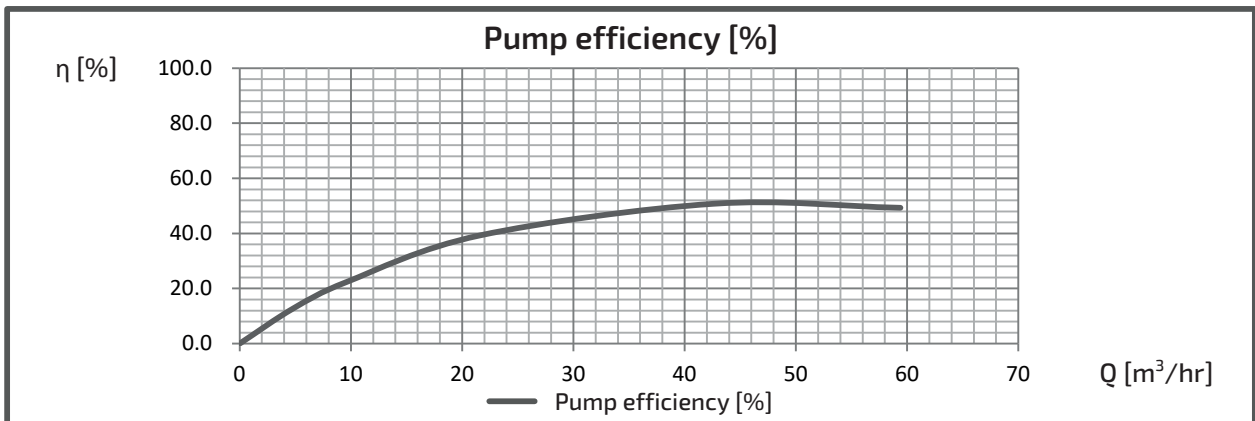
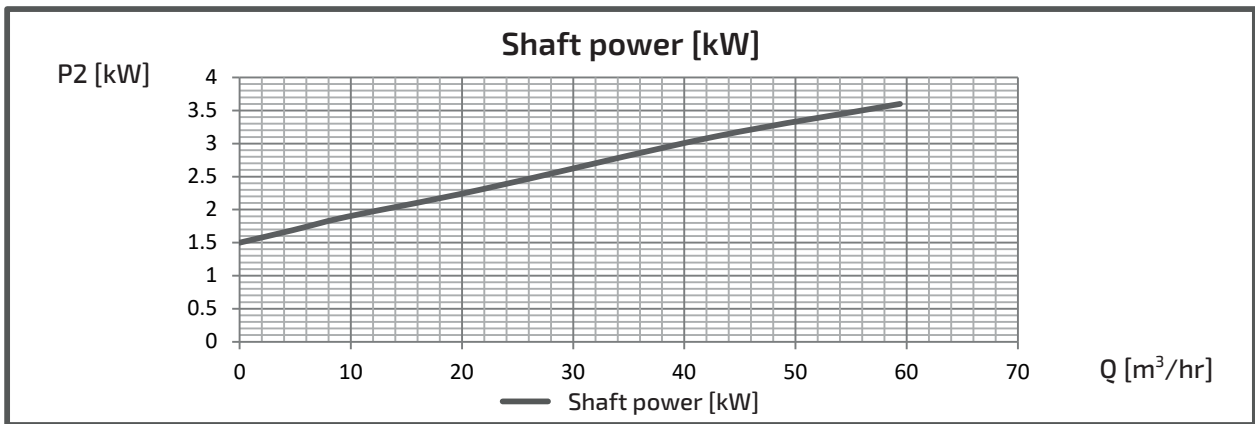
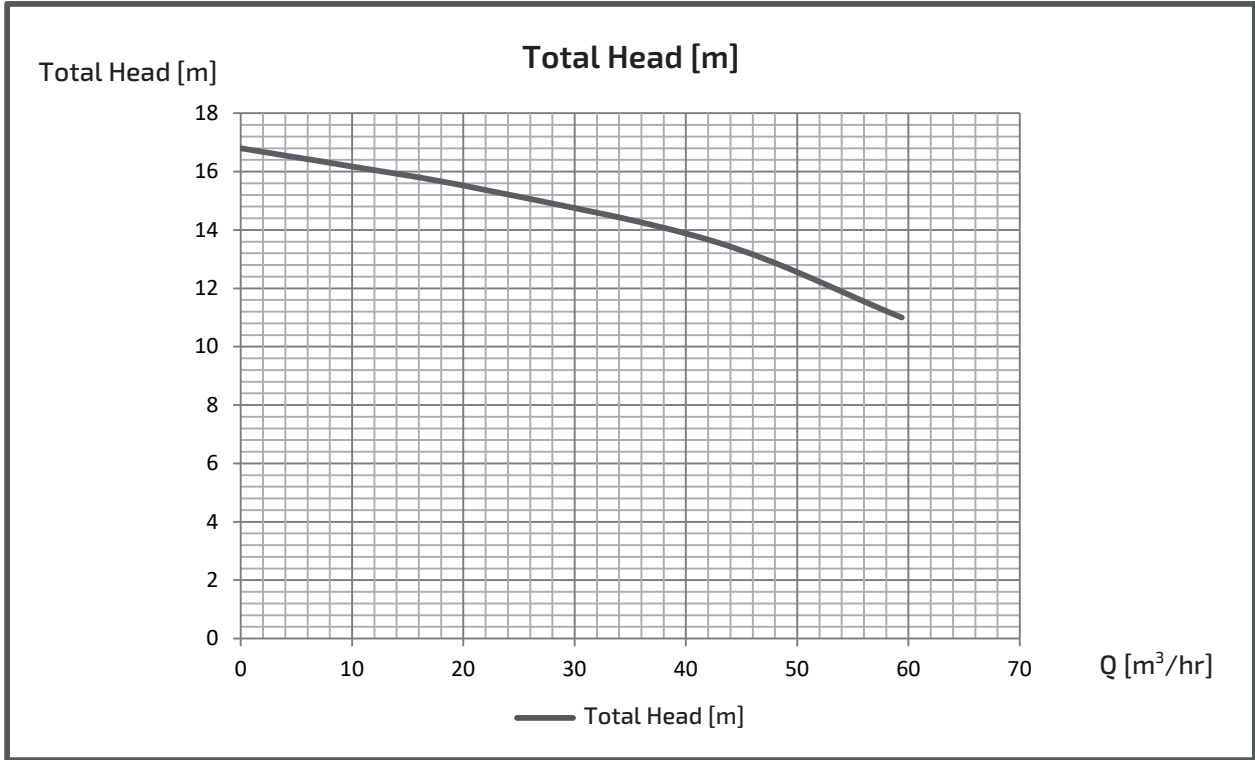

EXPECTED PERFORMANCE CURVE

MODEL : VU4-655-5.5T4

■ PERFORMANCE CURVES

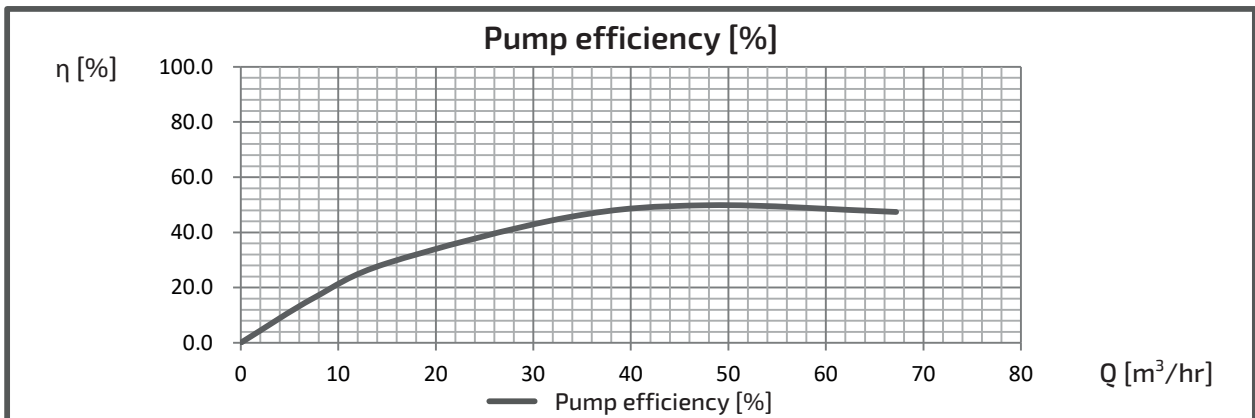
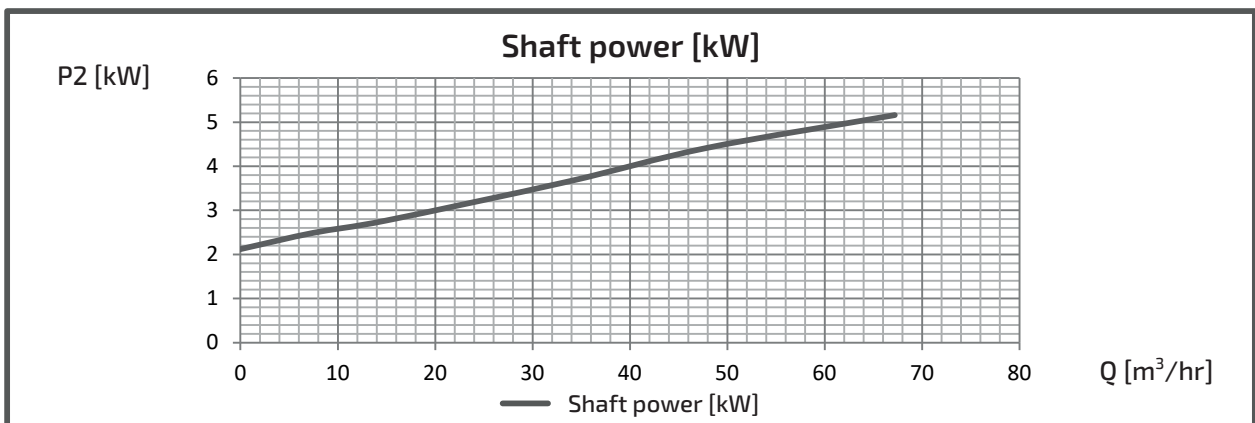
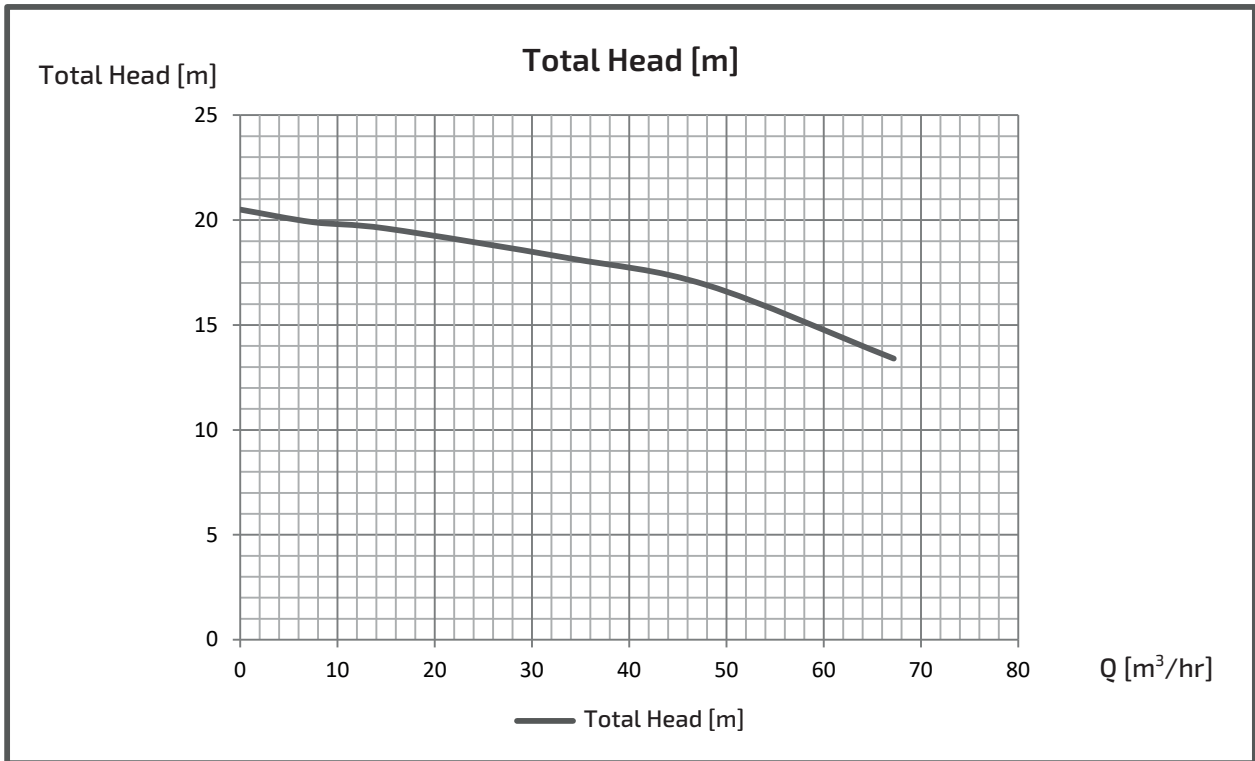

EXPECTED PERFORMANCE CURVE

MODEL : VU4-655-7.5T4

■ PERFORMANCE CURVES

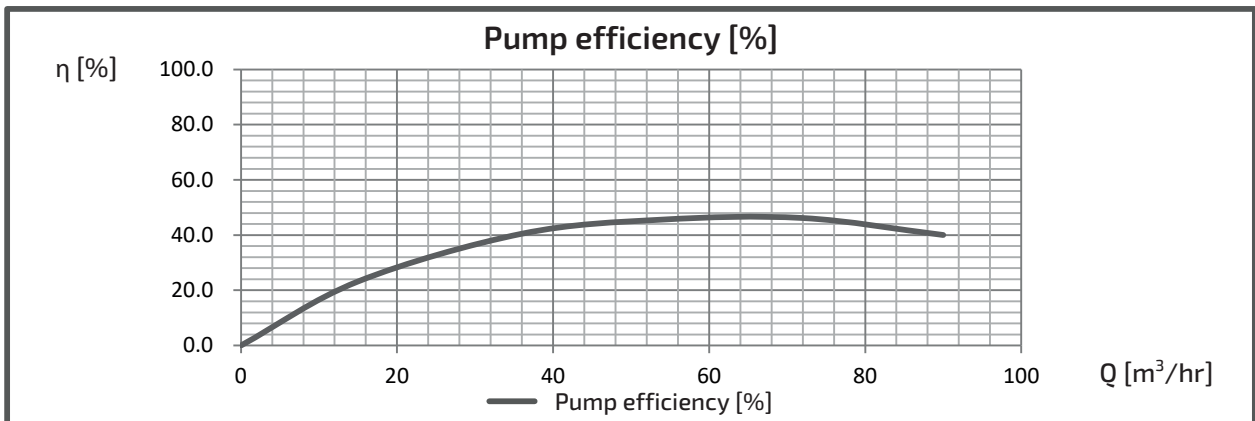
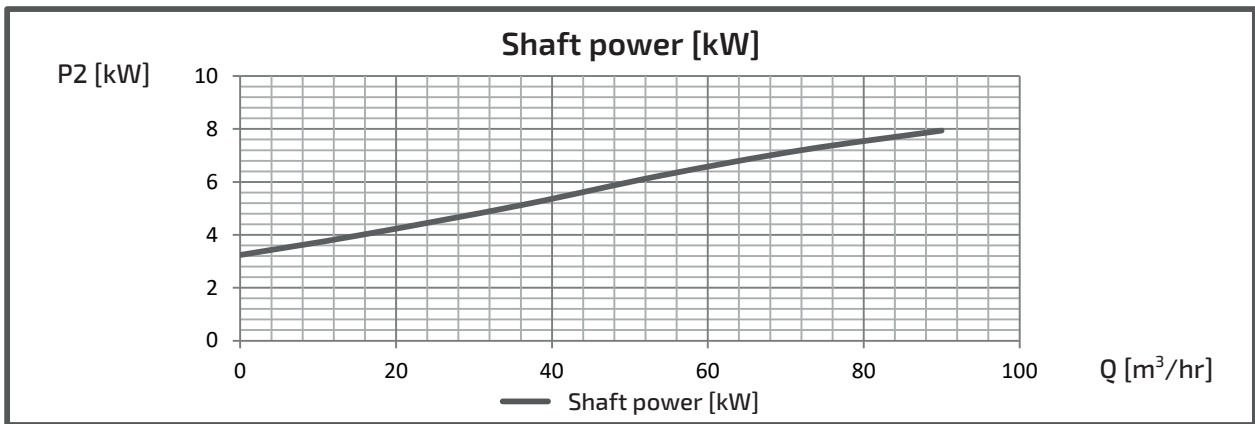
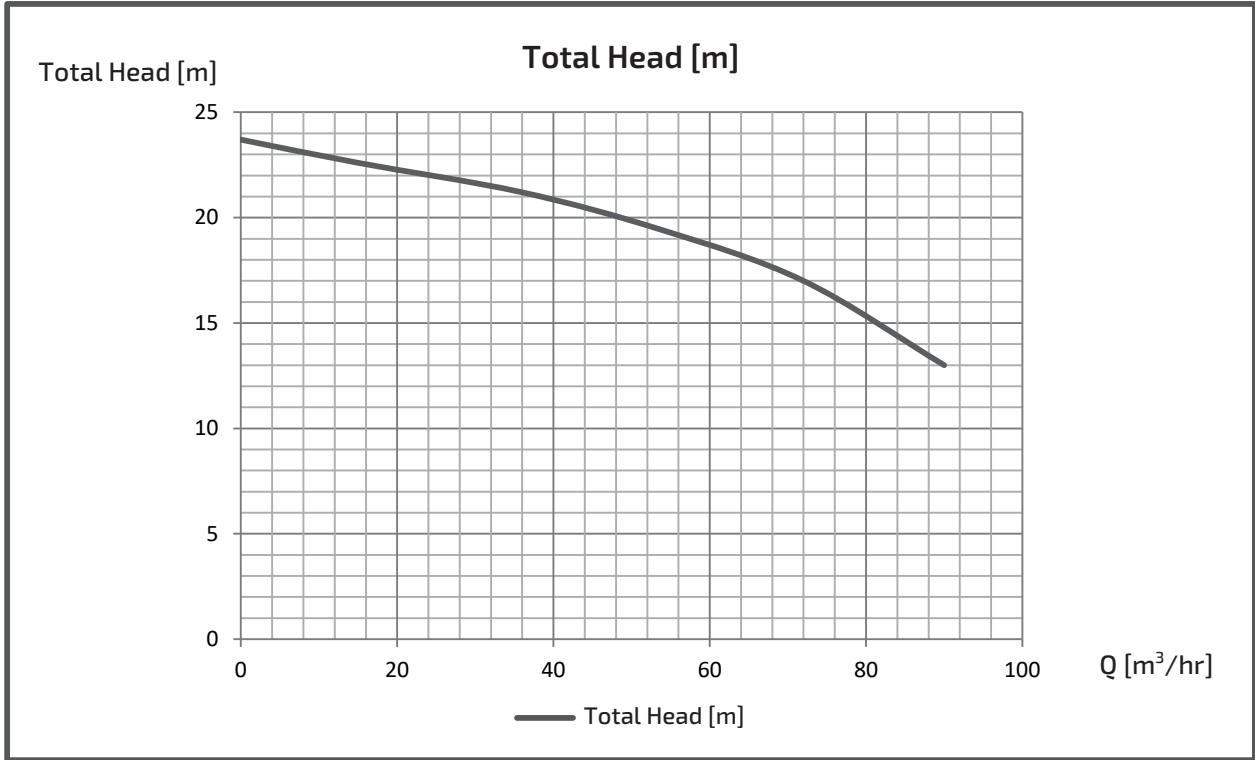

EXPECTED PERFORMANCE CURVE

MODEL : VU4-655-11T4

■ PERFORMANCE CURVES

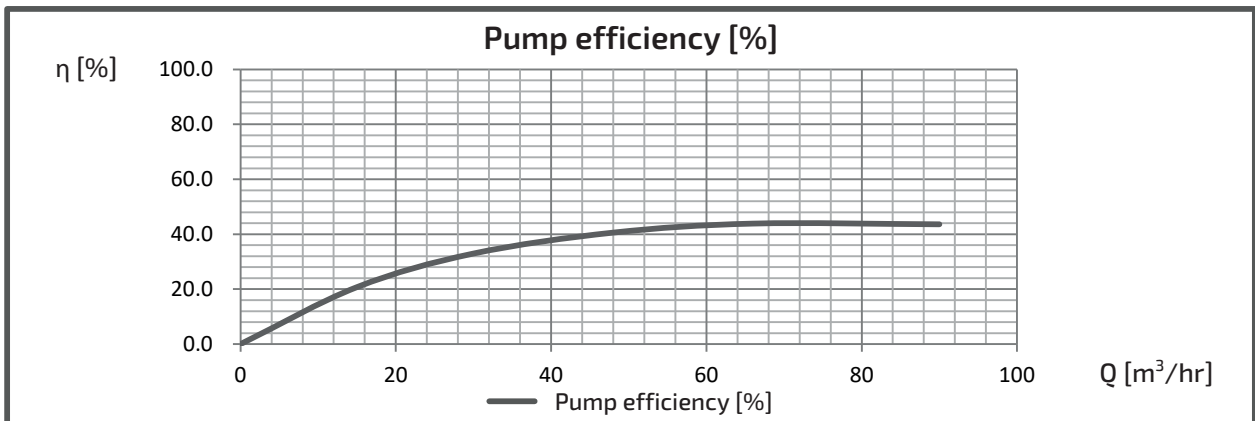
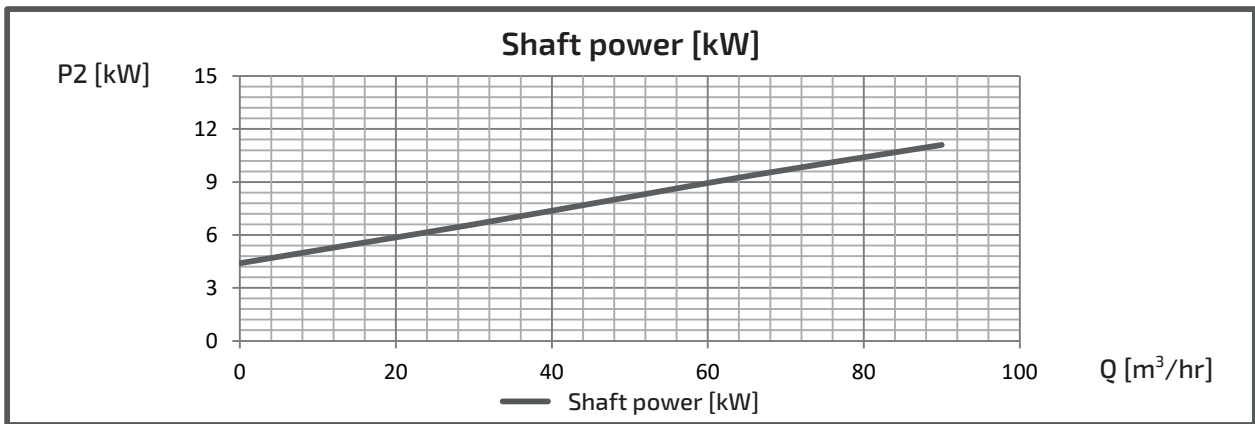
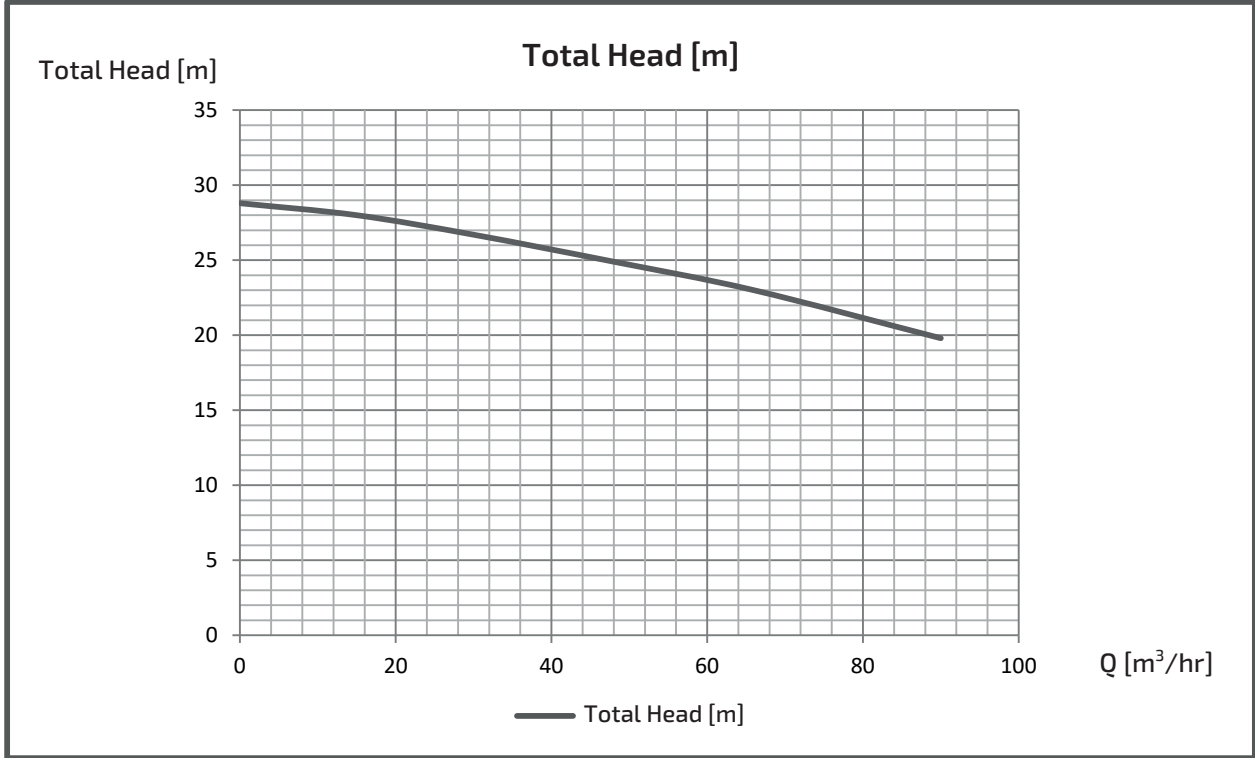

EXPECTED PERFORMANCE CURVE

MODEL : VU4-655-15T4

■ PERFORMANCE CURVES

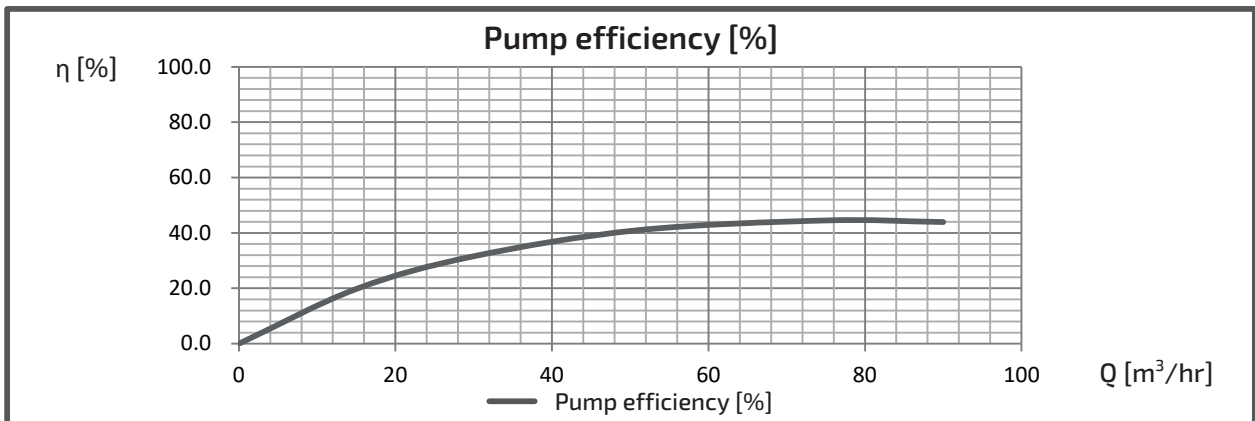
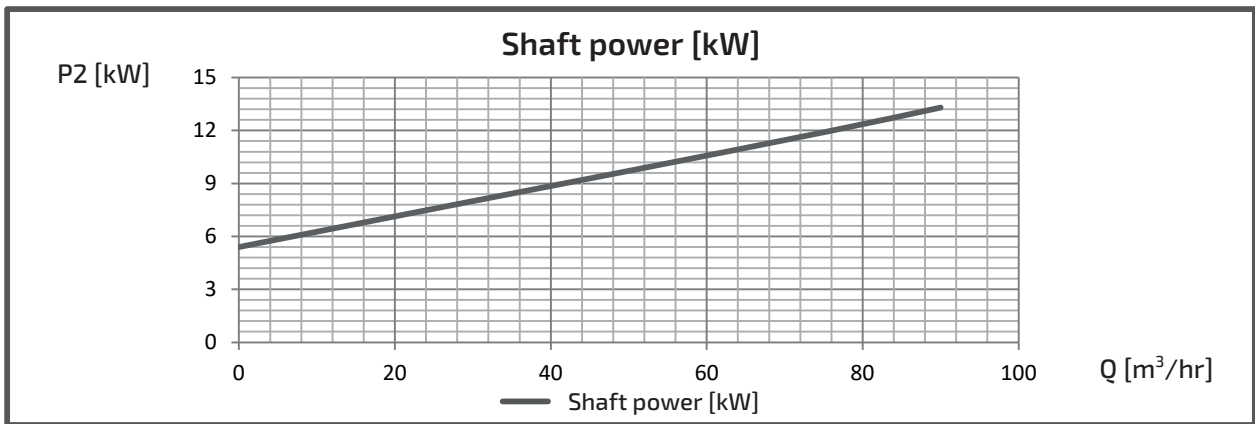
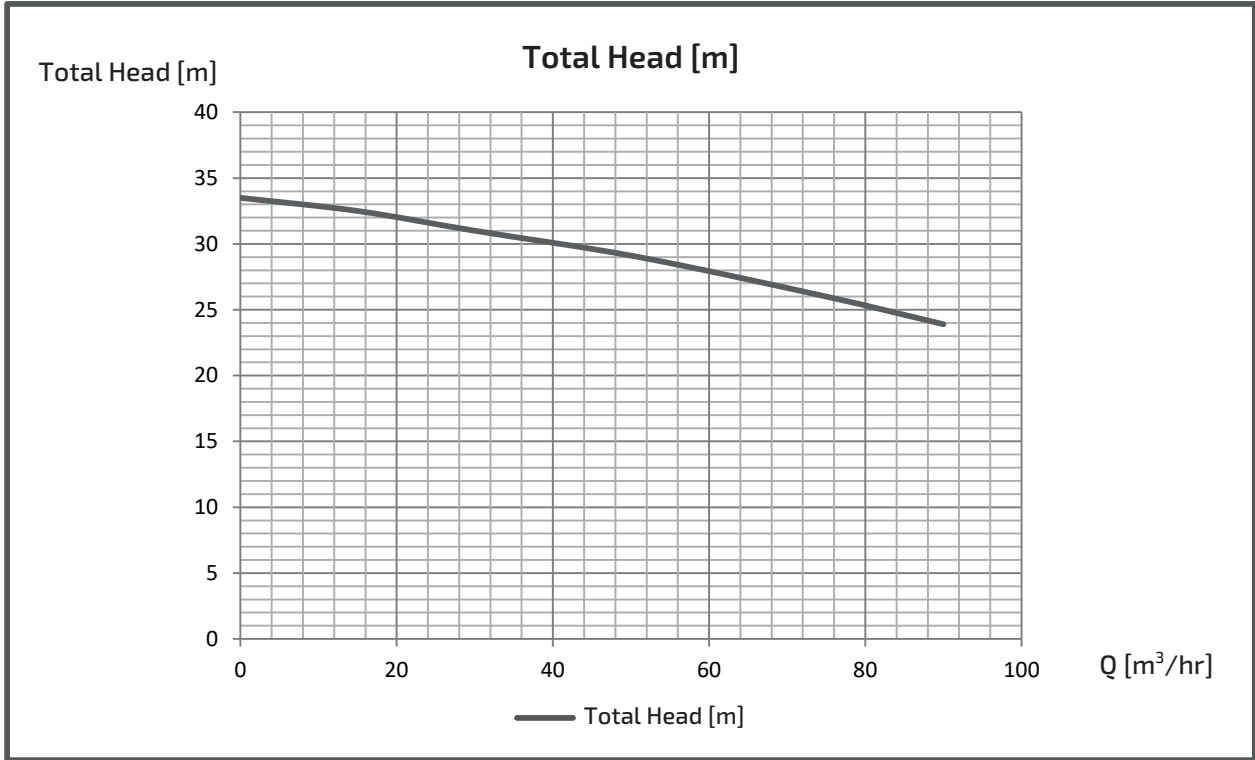

EXPECTED PERFORMANCE CURVE

MODEL : VU4-805-1.5T4

■ PERFORMANCE CURVES

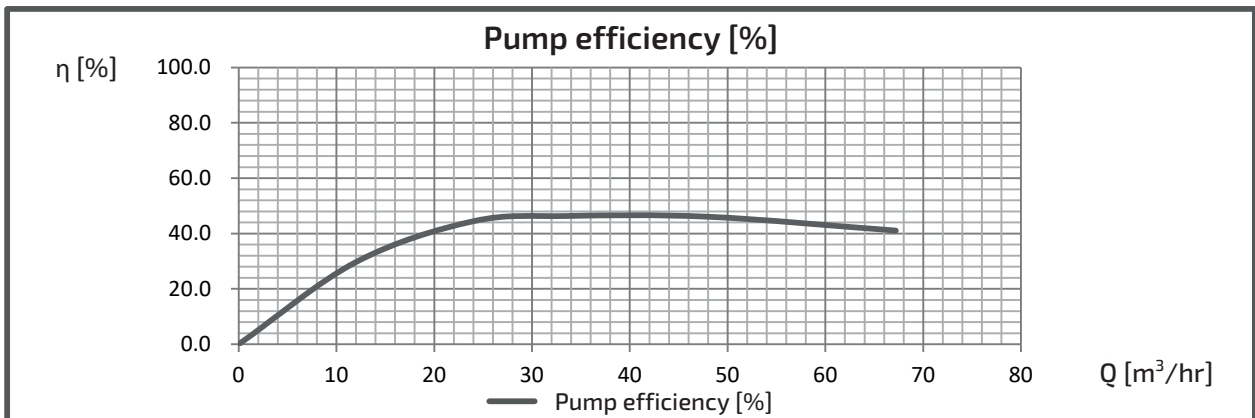
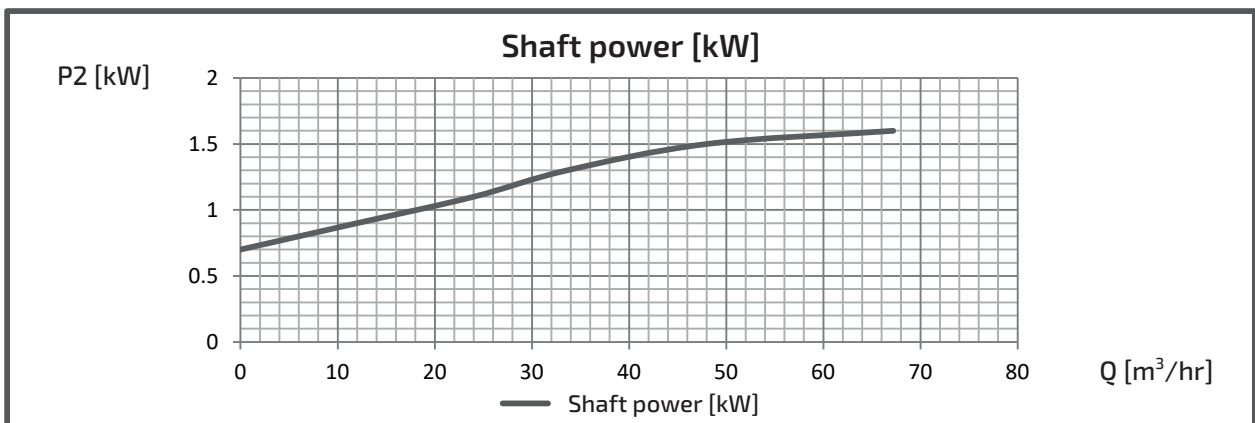
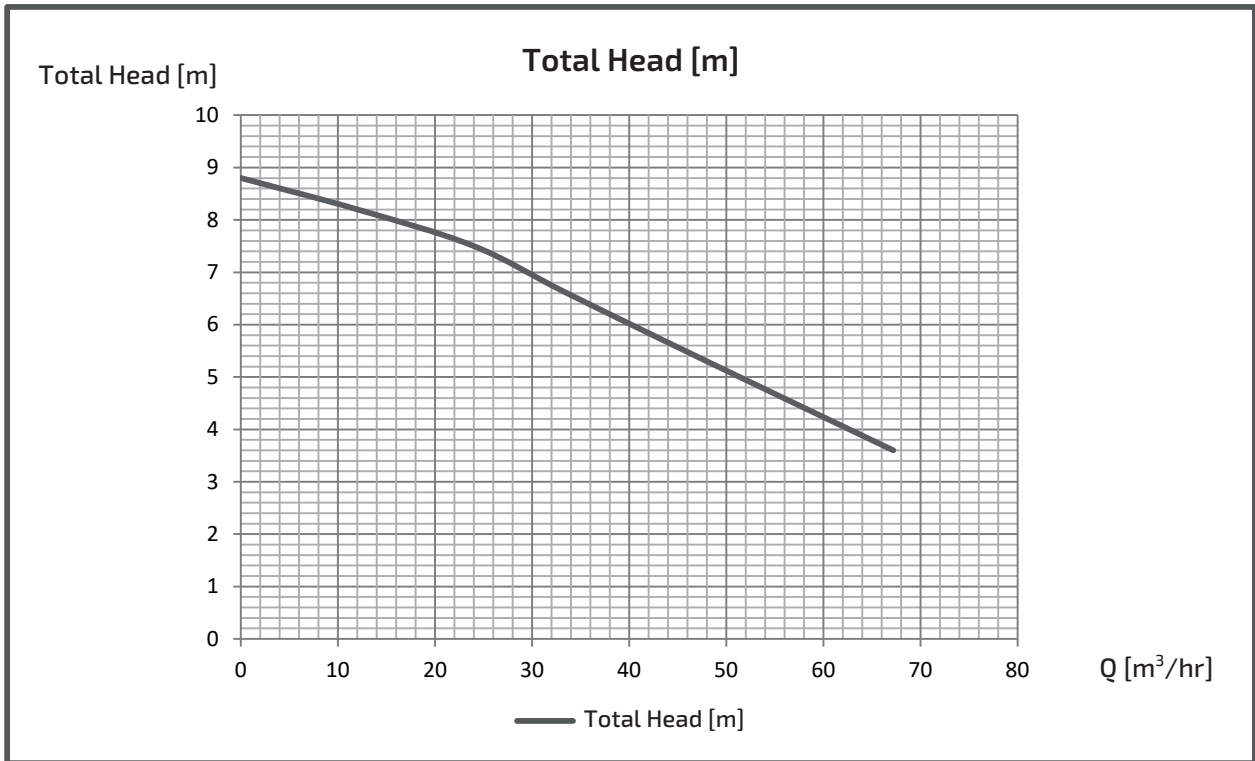

EXPECTED PERFORMANCE CURVE

MODEL : VU4-805-2.2T4

■ PERFORMANCE CURVES

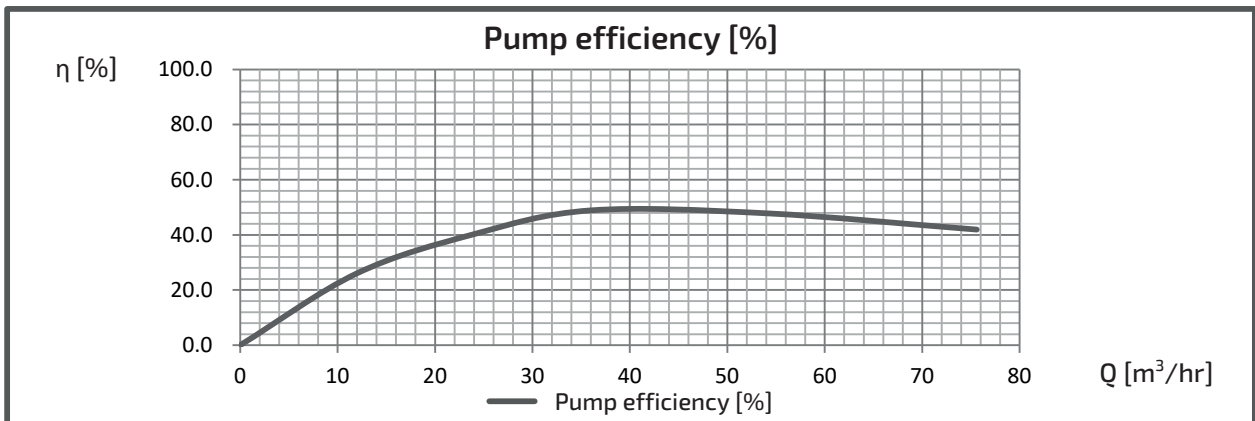
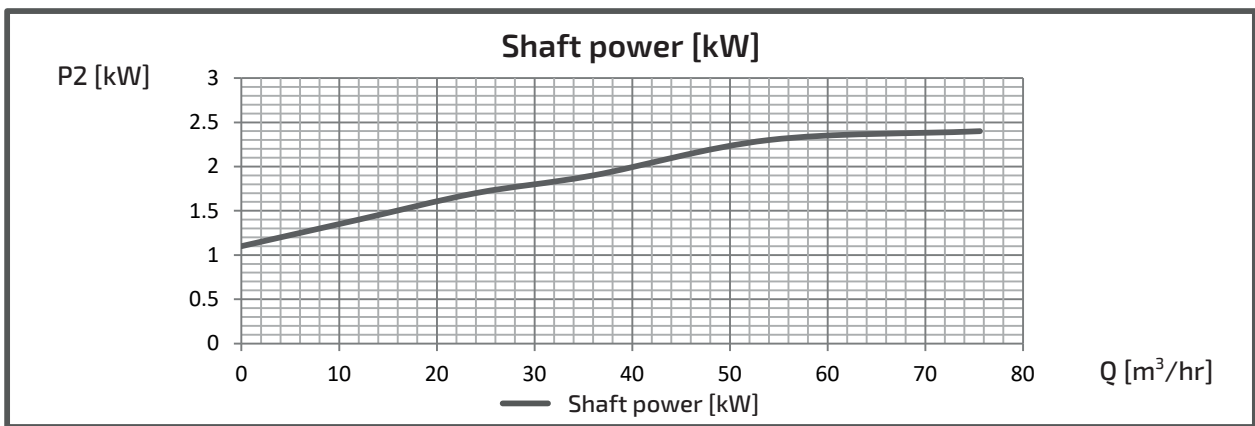
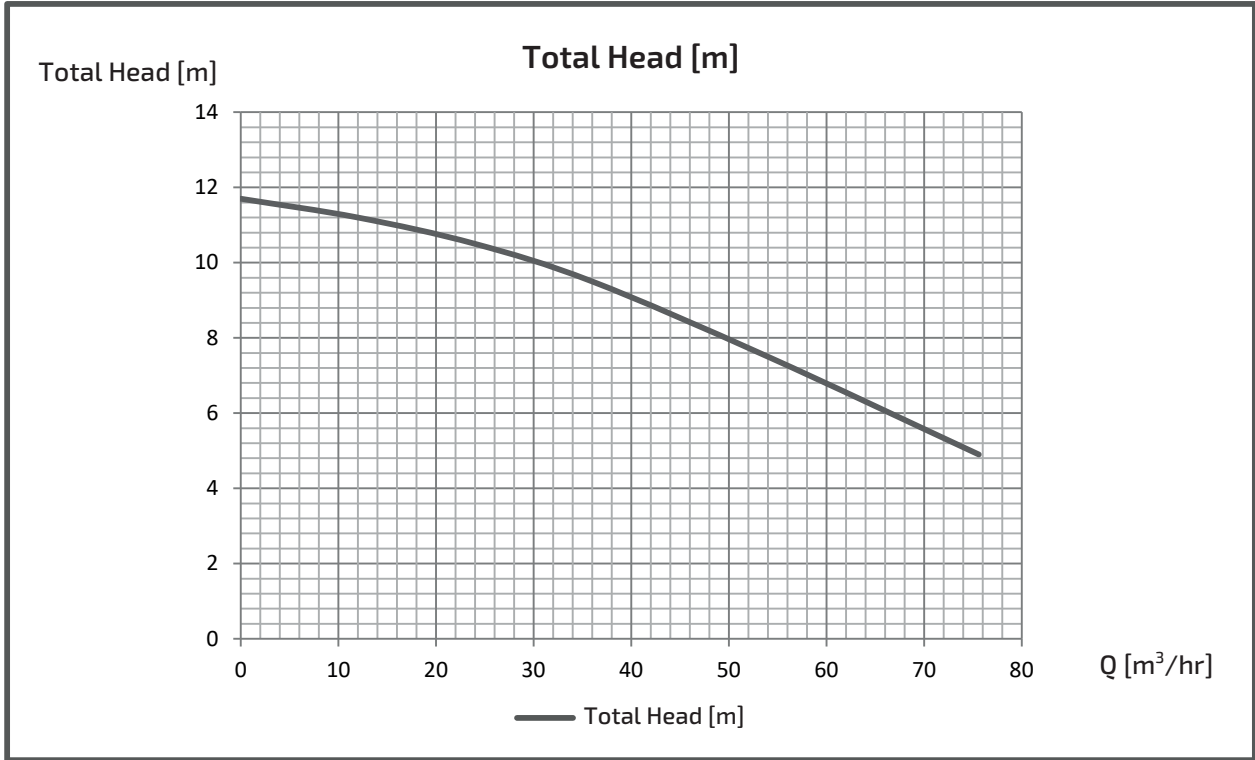

EXPECTED PERFORMANCE CURVE

MODEL : VU4-805-3.7T4

■ PERFORMANCE CURVES

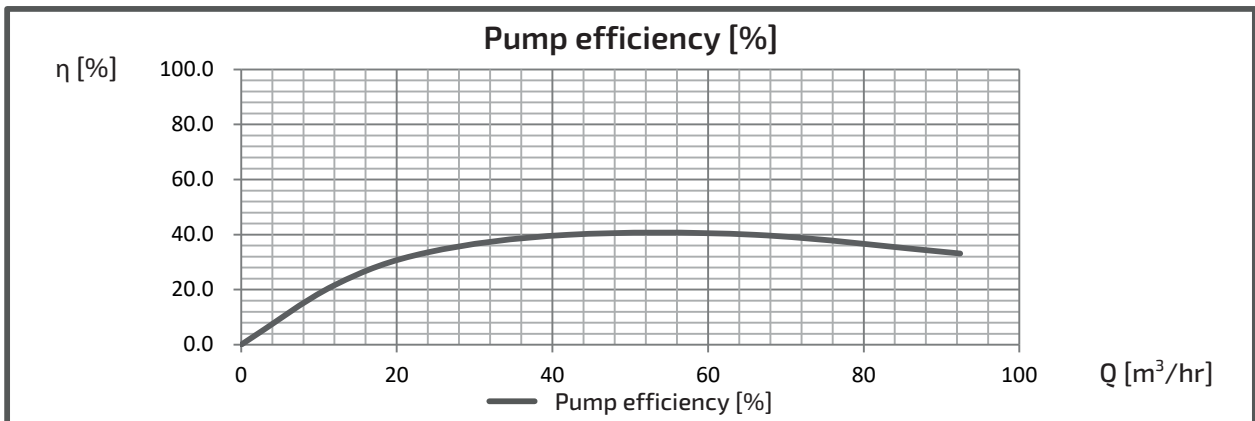
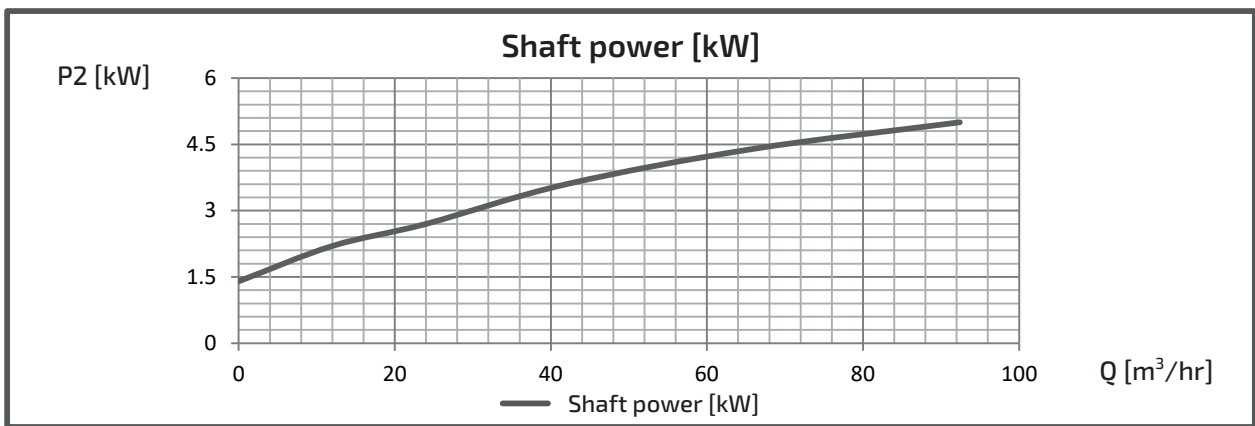
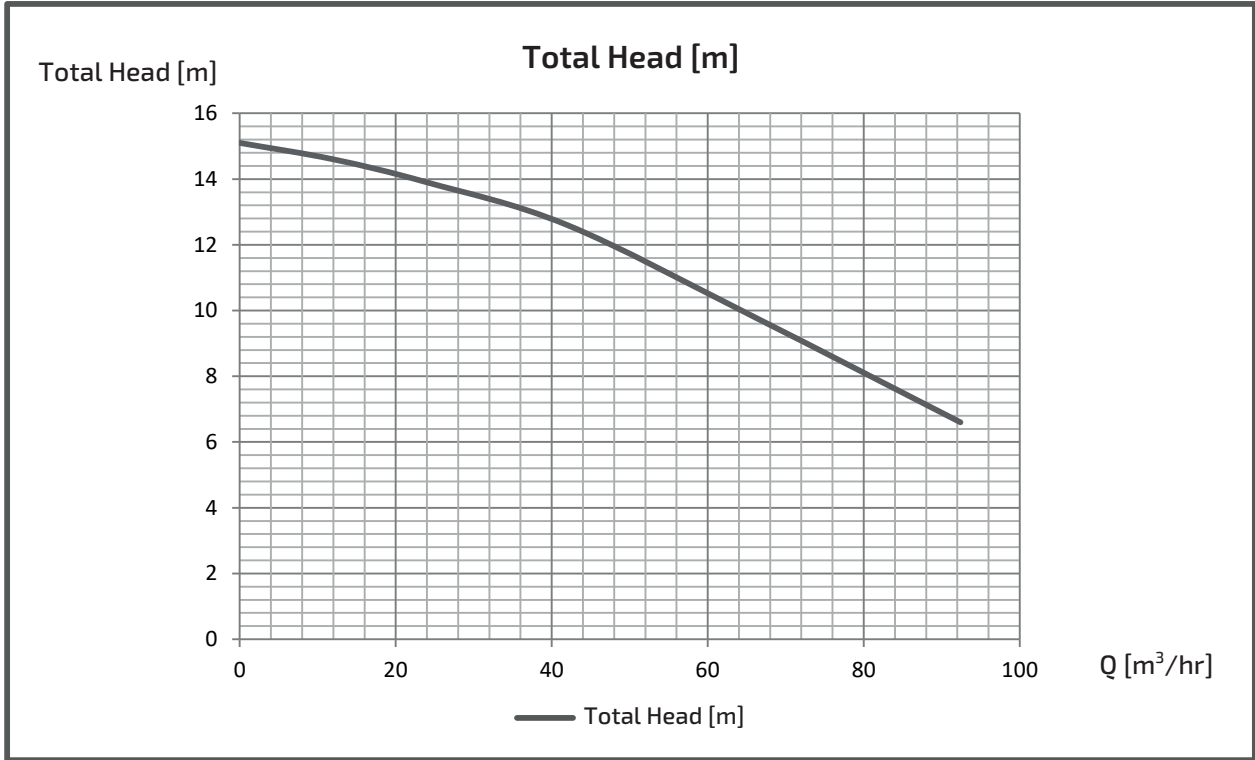

EXPECTED PERFORMANCE CURVE

MODEL : VU4-805-5.5T4

■ PERFORMANCE CURVES

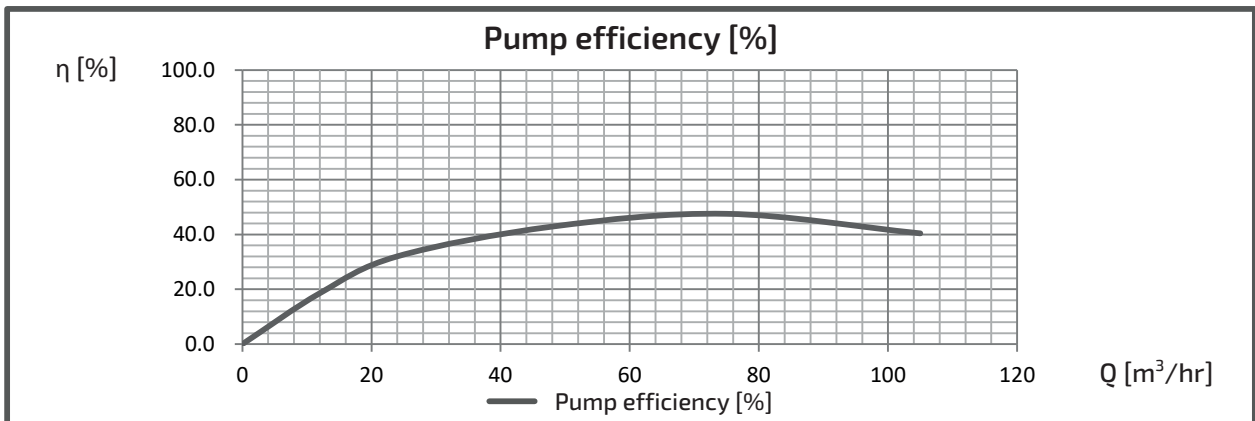
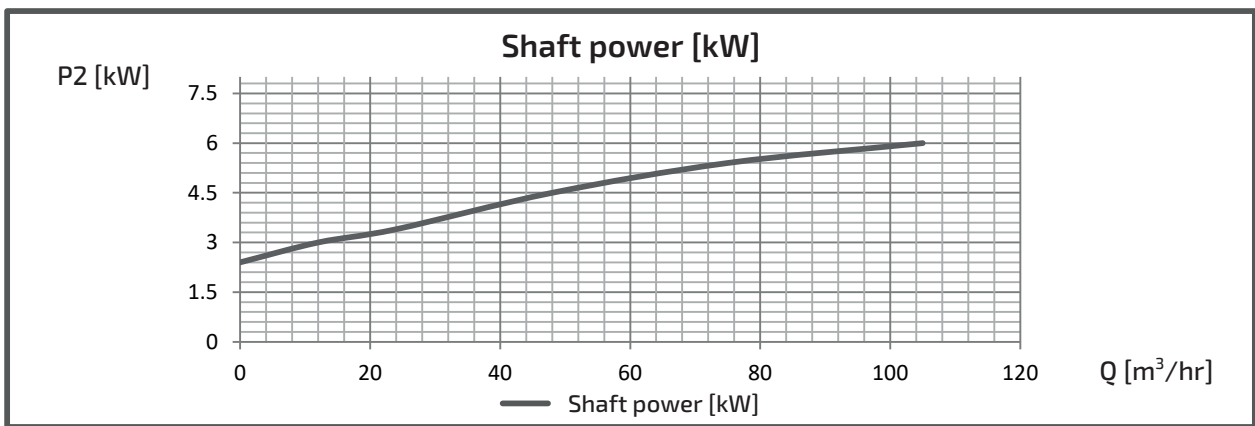
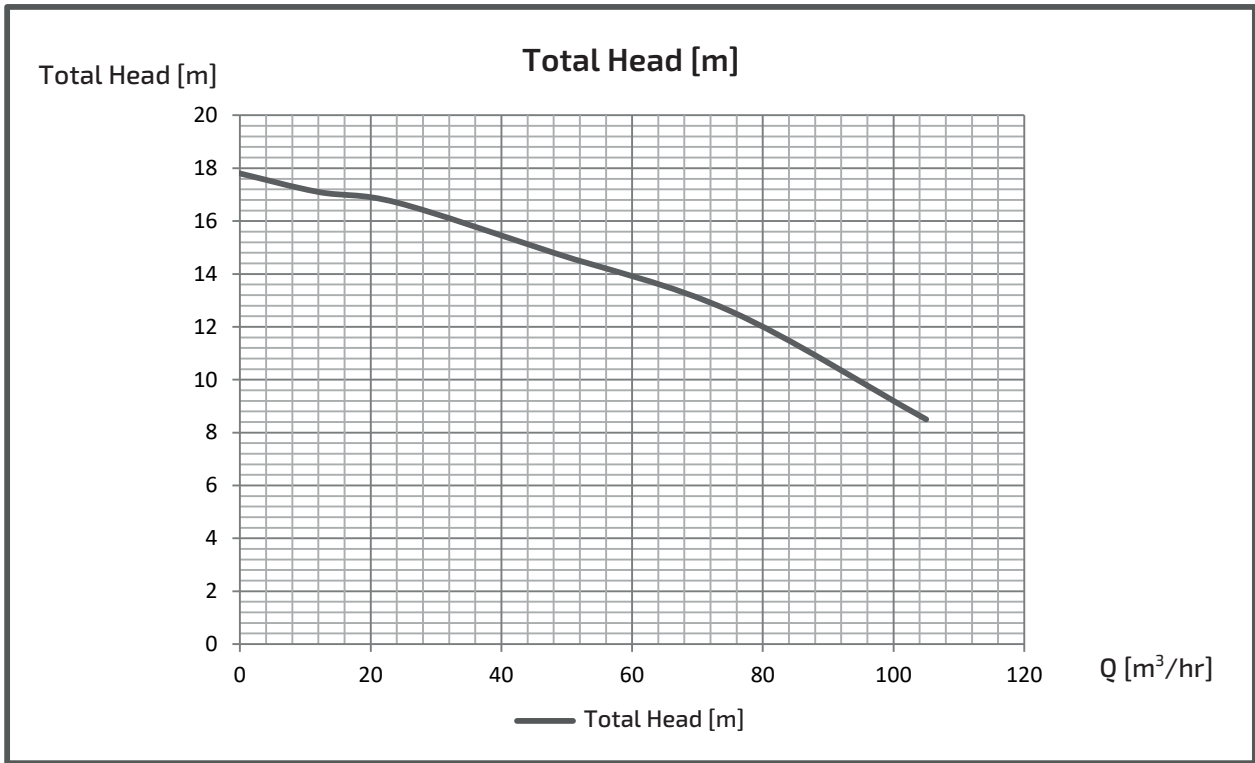

EXPECTED PERFORMANCE CURVE

MODEL : VU4-805-7.5T4

■ PERFORMANCE CURVES

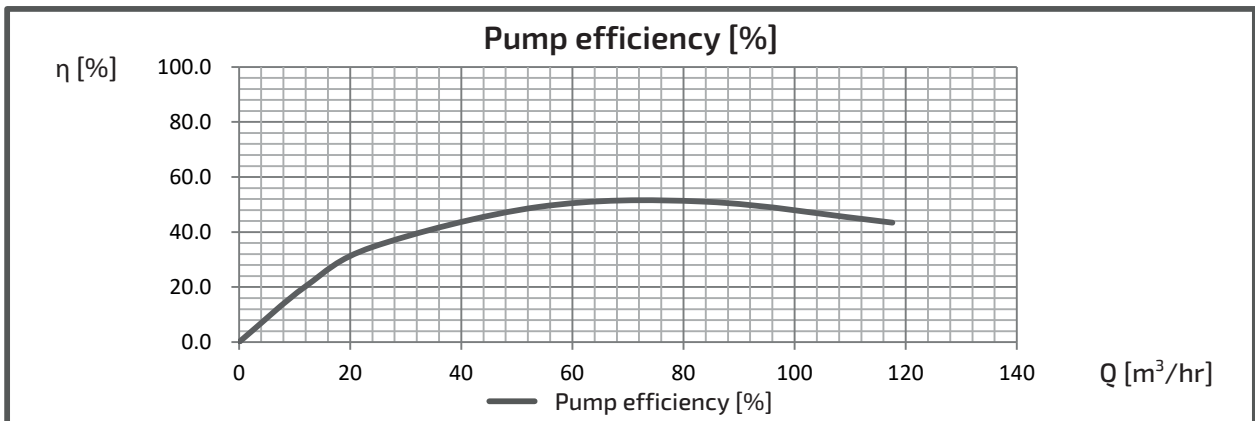
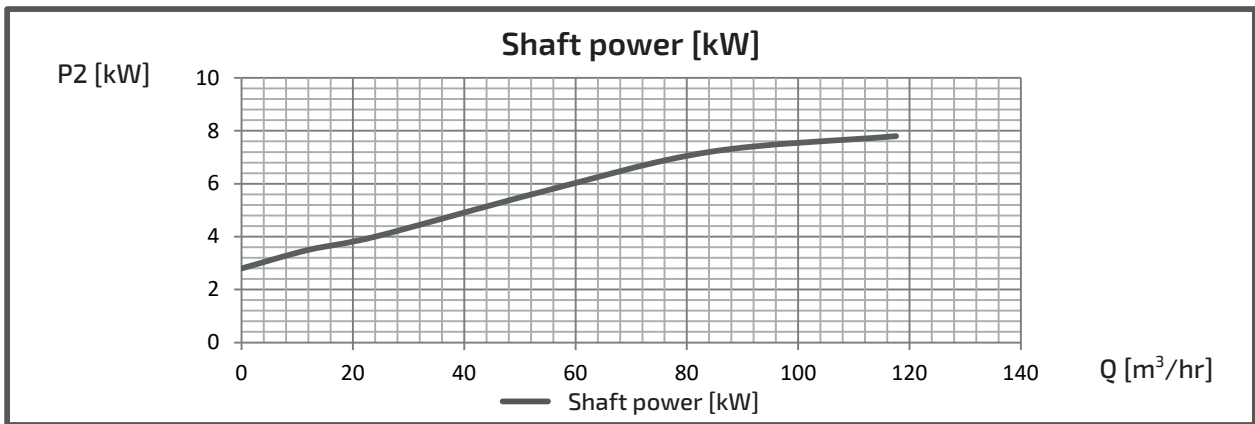
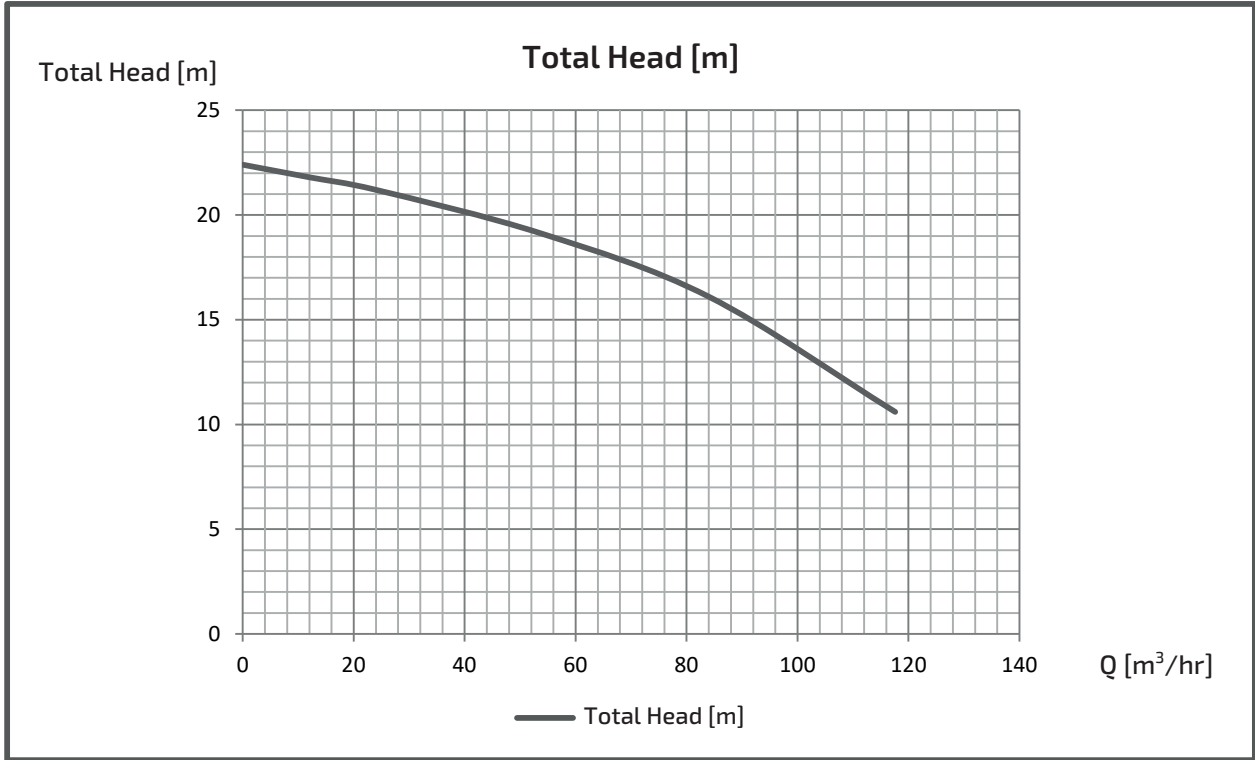

EXPECTED PERFORMANCE CURVE

MODEL : VU4-805-11T4

■ PERFORMANCE CURVES

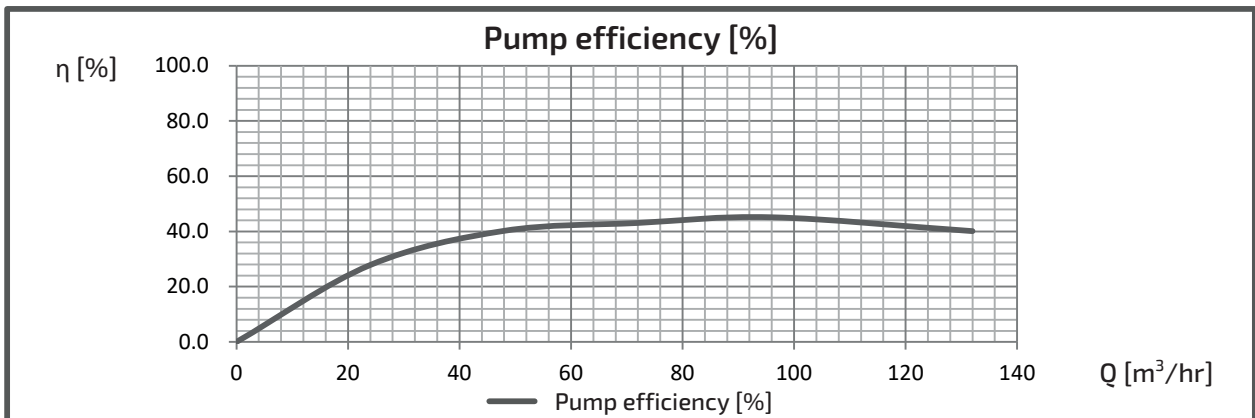
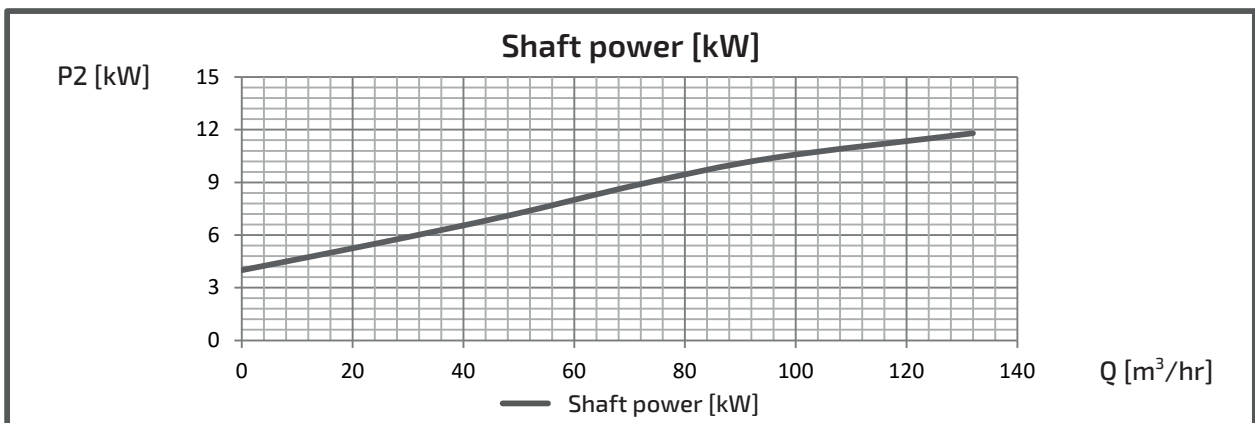
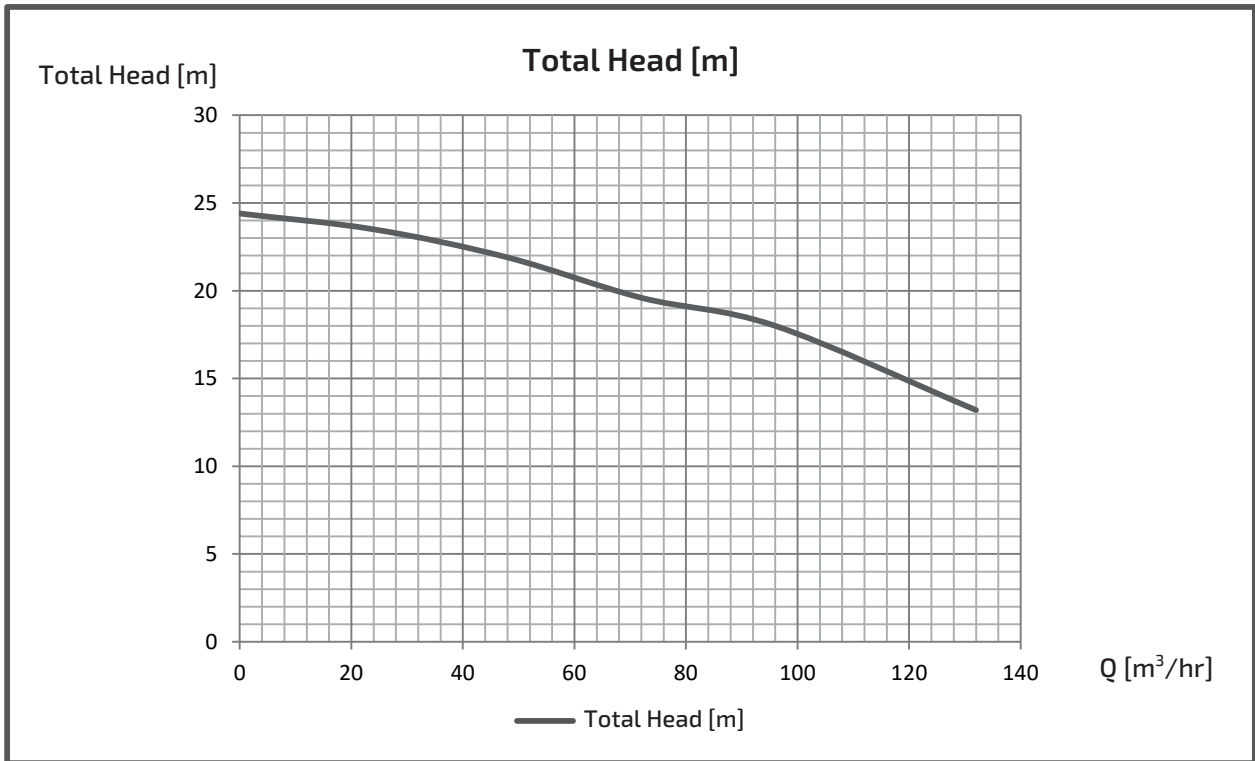

EXPECTED PERFORMANCE CURVE

MODEL : VU4-805-15T4

■ PERFORMANCE CURVES

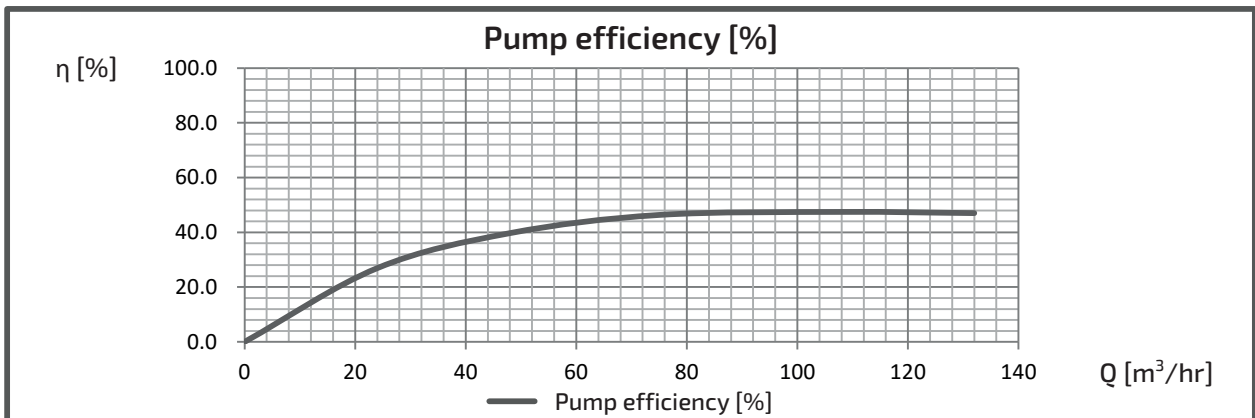
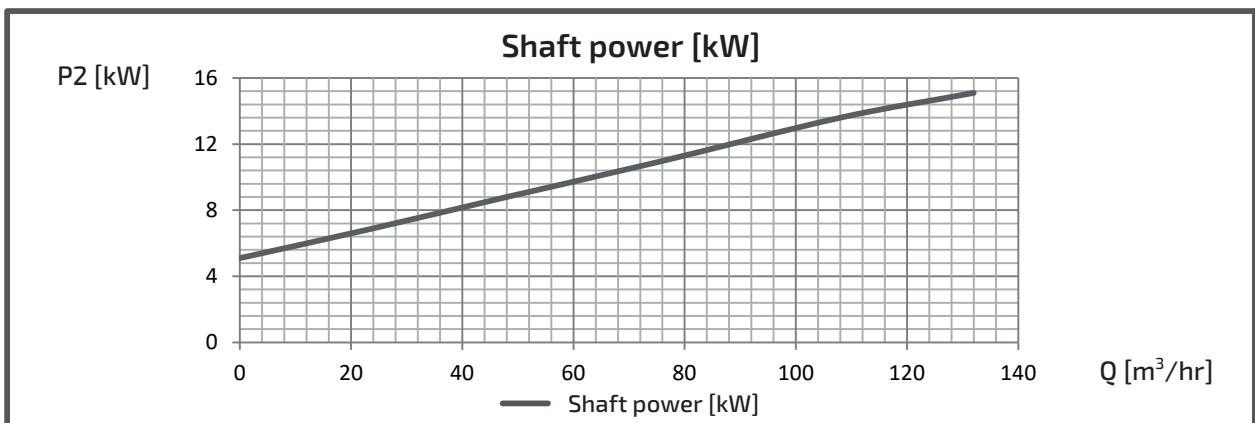
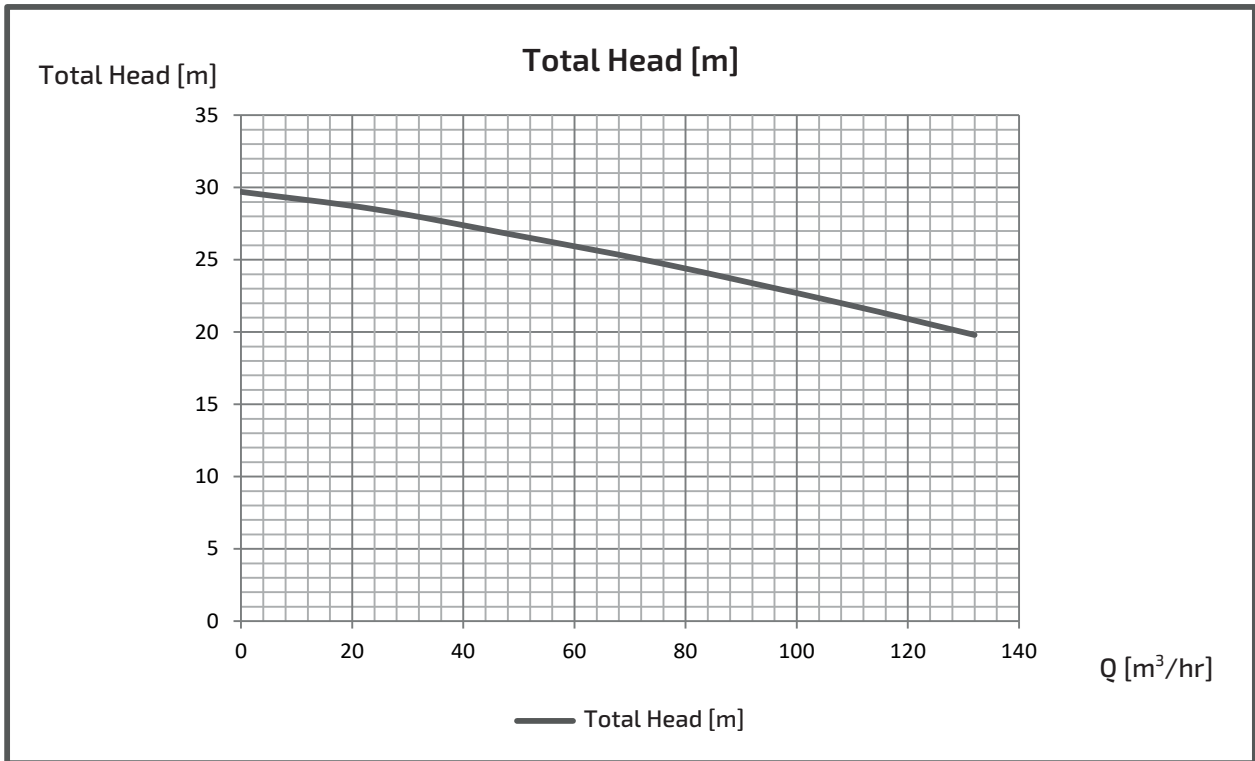

EXPECTED PERFORMANCE CURVE

MODEL : VU4-1005-3.7T4

■ PERFORMANCE CURVES

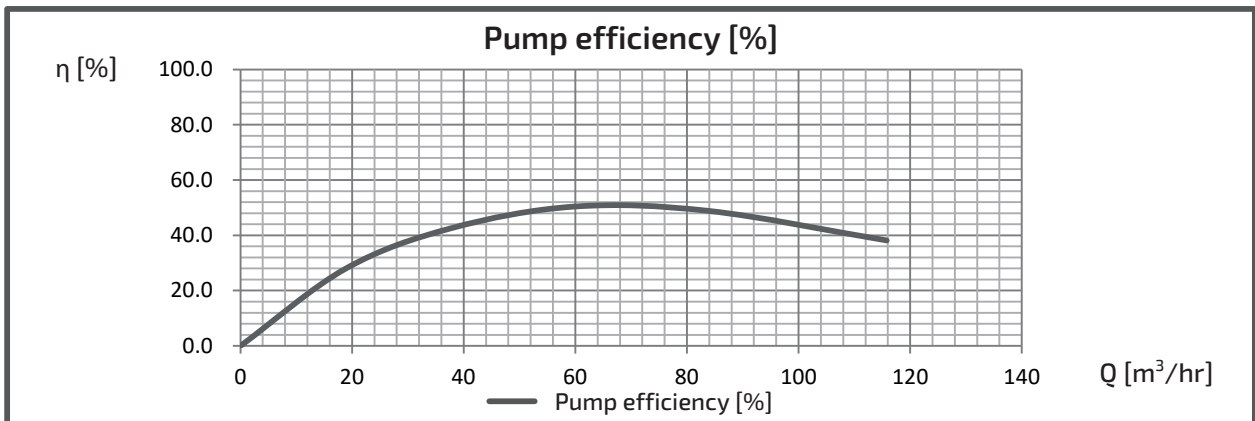
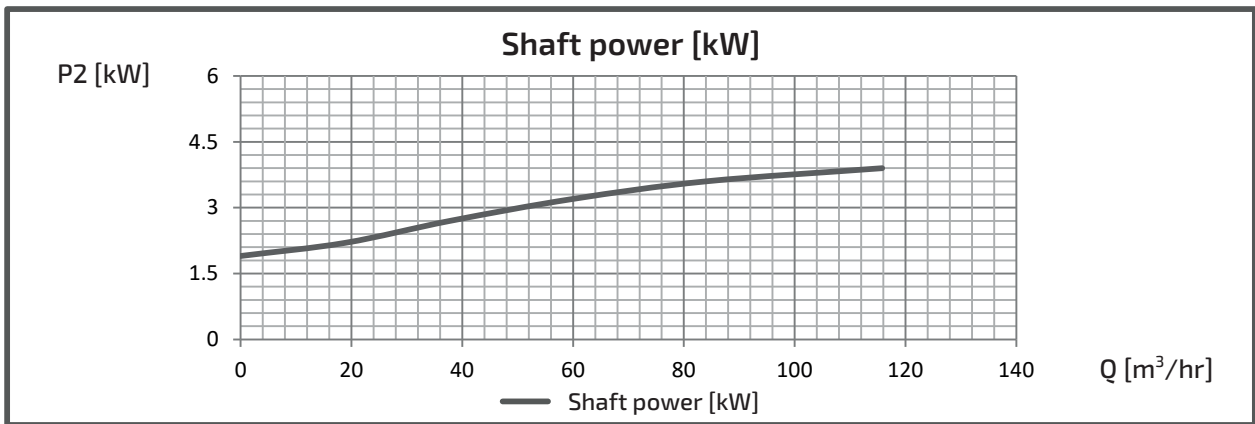
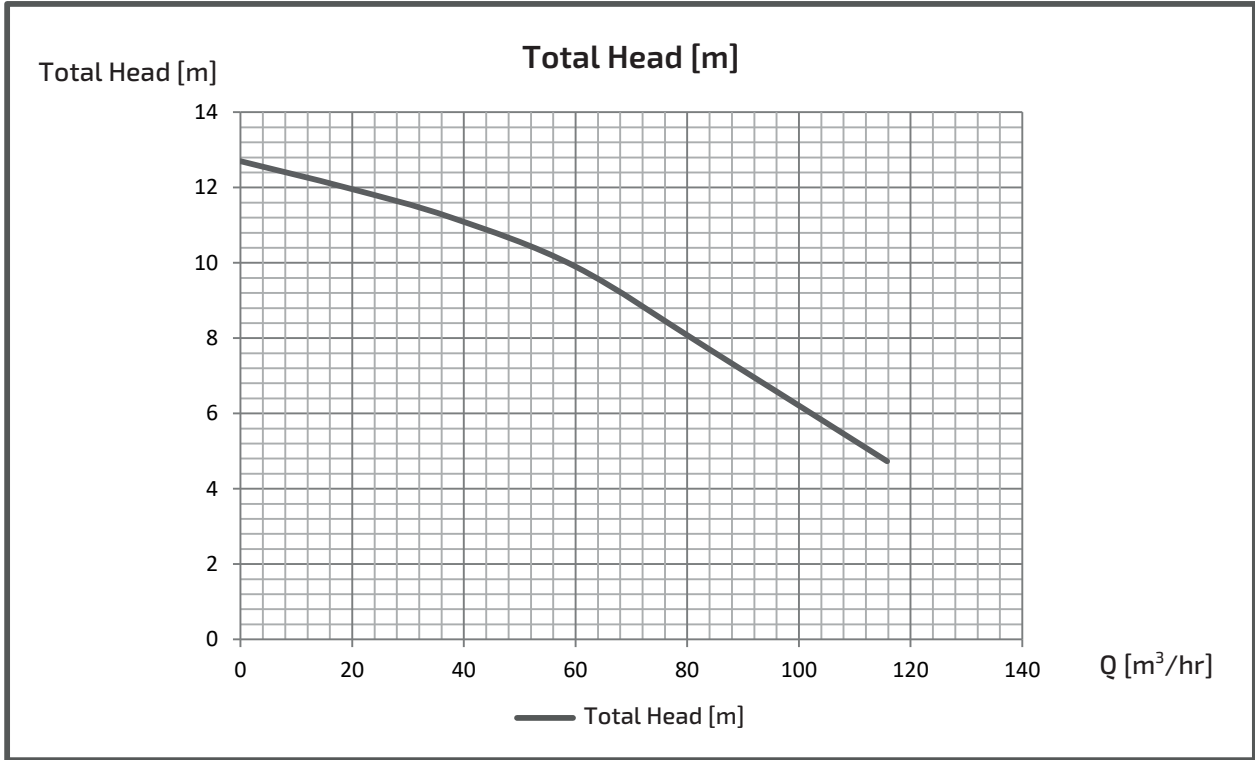

EXPECTED PERFORMANCE CURVE

MODEL : VU4-1005-5.5T4

■ PERFORMANCE CURVES

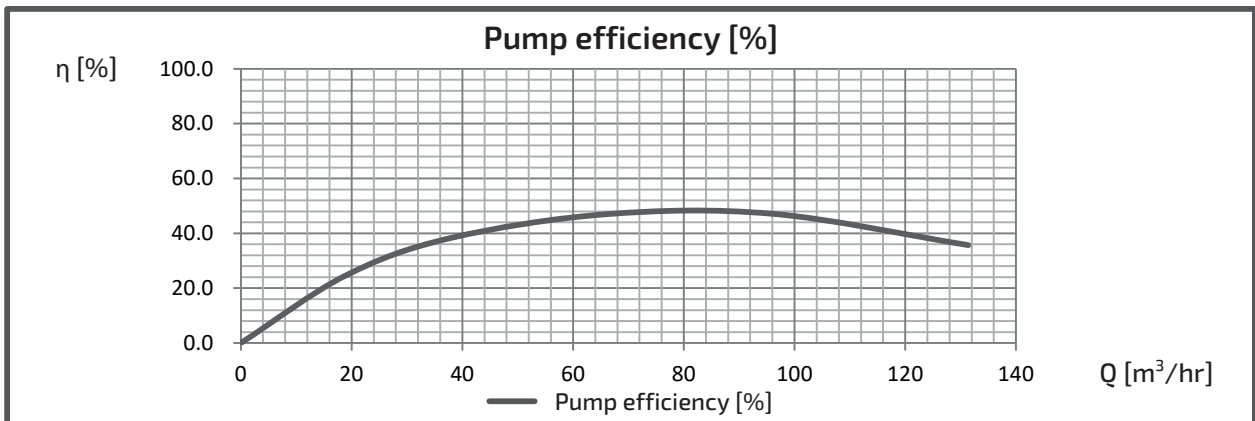
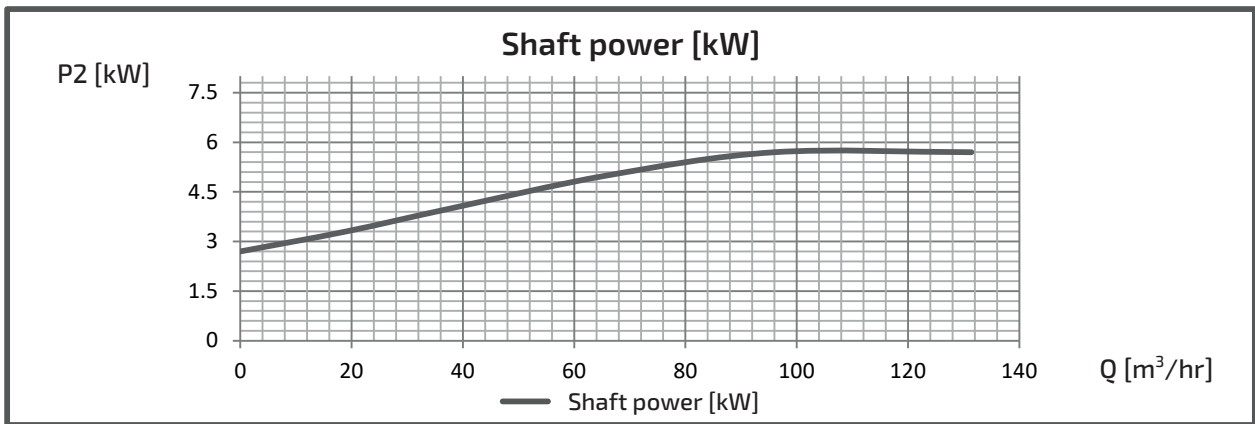
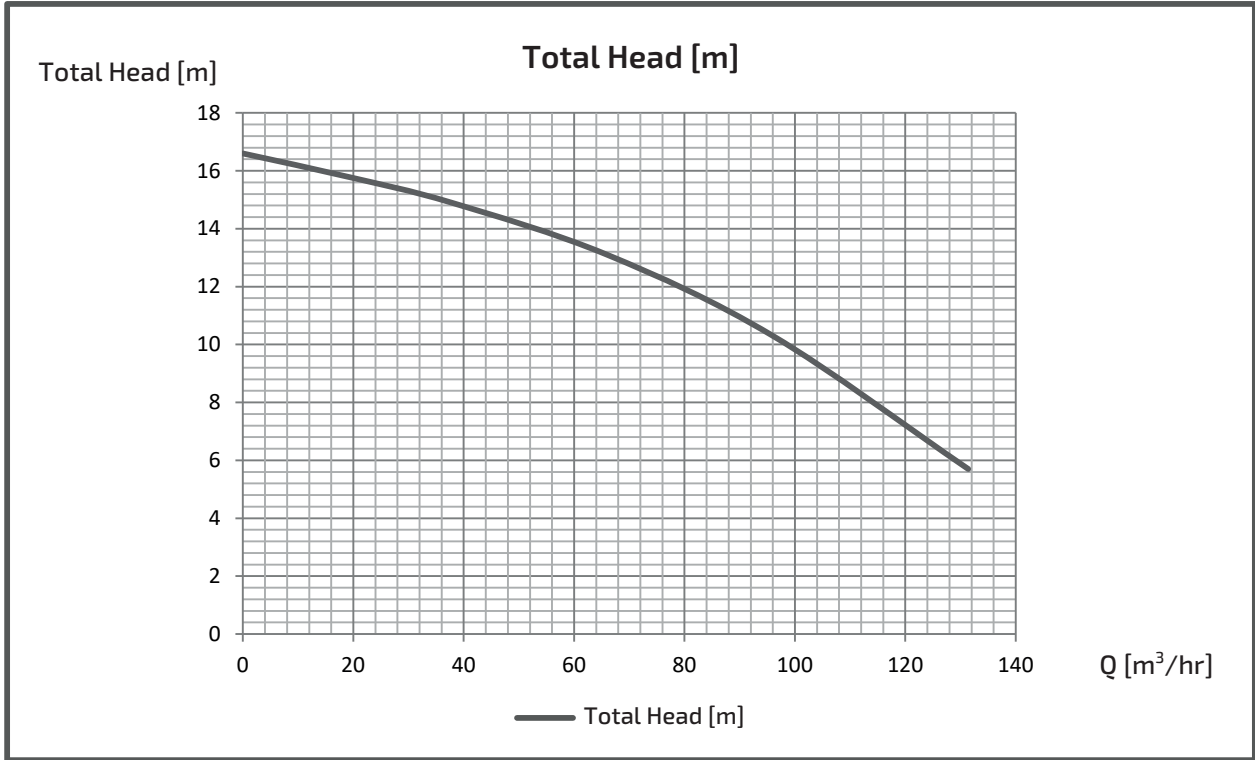

EXPECTED PERFORMANCE CURVE

MODEL : VU4-1005-7.5 T4

■ PERFORMANCE CURVES

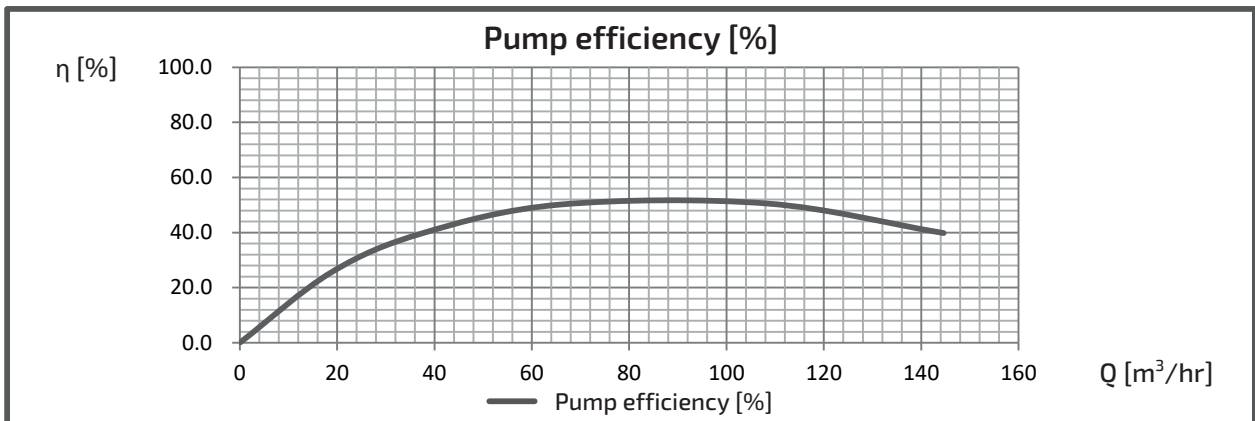
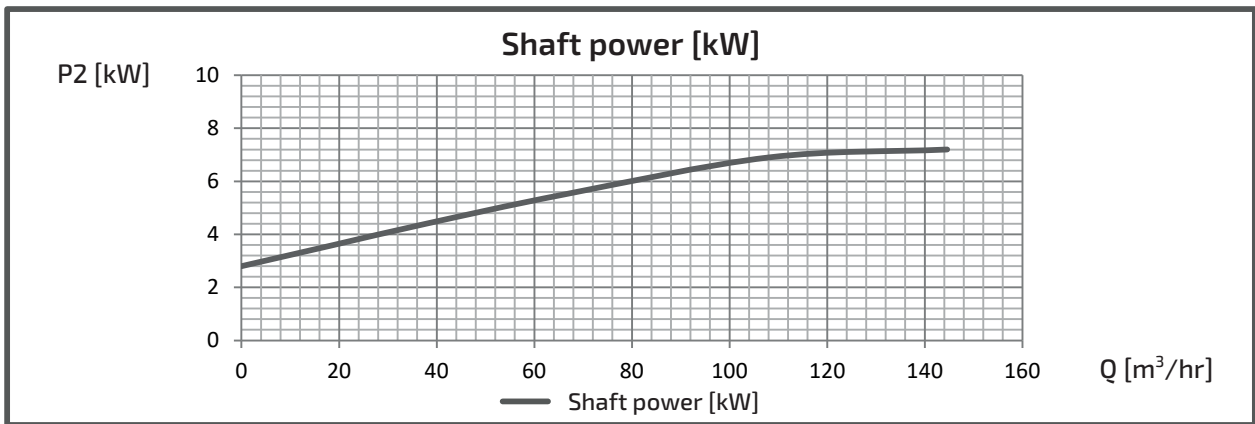
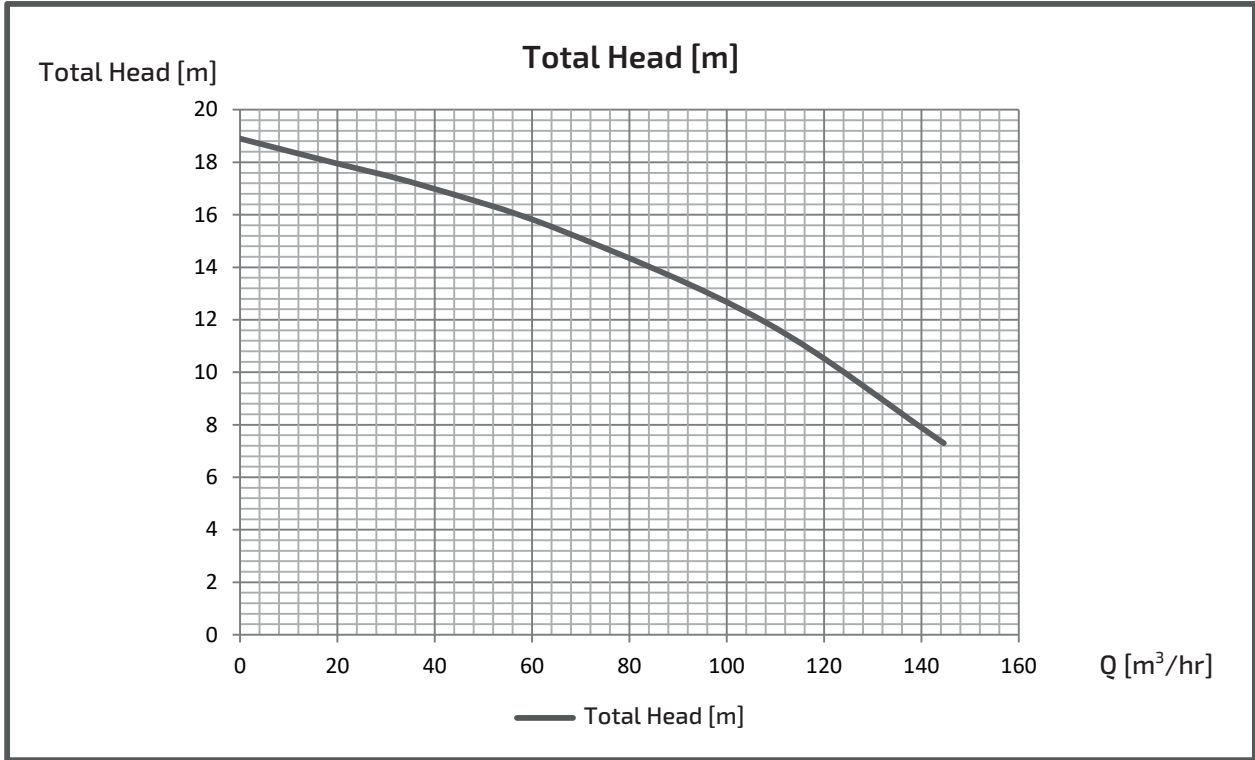

IMPORTANT SAFETY PRECAUTIONS

Always read the manual thoroughly and fully comprehend the contents for safe operation before starting use. Precautions for using products safely and for preventing personal injuries or physical damage are given in the manual.

- Matters falling under the following may not be covered by the warranty: uses out of the specified scope of application, failure to comply with precautions, improper repairs and alterations, matters arising from natural disasters, matters arising from the installation environment (improper power source, foreign objects, sand etc.), non-compliance with laws and regulations or standards pertaining thereto, accidental or intentional damage or injury, replacement of consumable parts, defects due to resale, etc.
- Do not use the product for applications out of the product specifications. Doing so may cause electric shock, fire, water leakage, etc.
- Have spare equipment ready when using pumps for equipment for living things (fish farms, fish tanks, aquariums, etc.) or critical equipment.
- Pump failure may cause lack of oxygen and water quality deterioration, and may affect the lives of the living things.
When using pumps for equipment for living things (fish farms, fish tanks, aquariums, etc.), do not install the pump in the tank where the living things are put into. The current leakage or sealing liquid leak from the mechanical seal may cause the death of the living things.
- If used to transport food-related items, give due consideration to the materials used. Contamination by foreign objects may occur.
- Avoid using for living things which disagrees with copper alloy. It may affect the lives of the living things.
- Select a product which is appropriate for your application. Inappropriate use of products may cause accidents.
- Conduct construction in accordance with the applicable laws and regulations (the Technical Standards of Electric Installation, interior wiring regulation, Building Standards Act, Water Supply Law, etc.). Not only does it violate the laws and regulations, but it also may cause injuries due to electric shock, fire, falling and tipping over.
- Do not use in places where people are assumed to get in contact with the product (baths, pools, lakes, etc.). Electric leak may occur and cause electric shock.
- Depending on the equipment, attach a filter etc. appropriate for your application on the discharge side before use, perform thorough flushing to check that there is no contamination. Cutting oil, rubber mold releasing agent, foreign objects etc. from the manufacturing line and cutting oil, foreign objects etc. from the pipeline may contaminate the liquid which is to be handled.
- Do not operate pumps with a specification of 50Hz at 60Hz. It may cause damage due to overpressure or burn damage of motors etc. due to overload. Do not operate pumps with a specification of 60Hz at 50Hz. Pump performance may be reduced.
- Only repair technicians may disassemble, repair, modify the product or replace cables. Defects may cause failure, damage, electrification or fire.
- It is recommended that both periodic and daily inspections be performed in order to ensure that the pump will operate reliably for as long as possible. Failure to perform inspections may lead to pump failure, accidents etc. For periodic inspections, please consult your distributor or our nearest sales office.

Note

Specifications/Configurations may be altered as a result of improvements and such.
Unauthorized reproduction of this document is prohibited.