

GS02/3-C

GS2/3-C

GS-M

KAWAMOTO SELF-PRIMING PUMP
2 POLES / 50 Hz

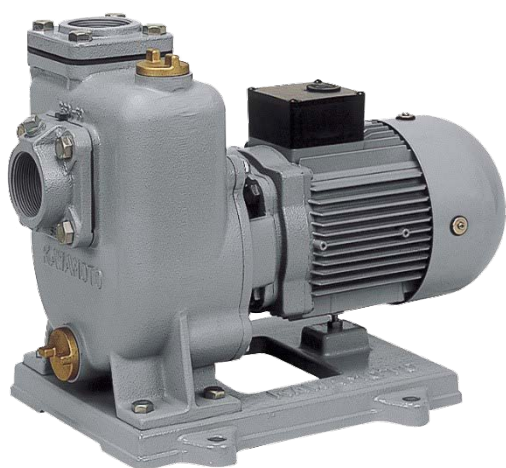

GS02/3-C



GS2/3-C

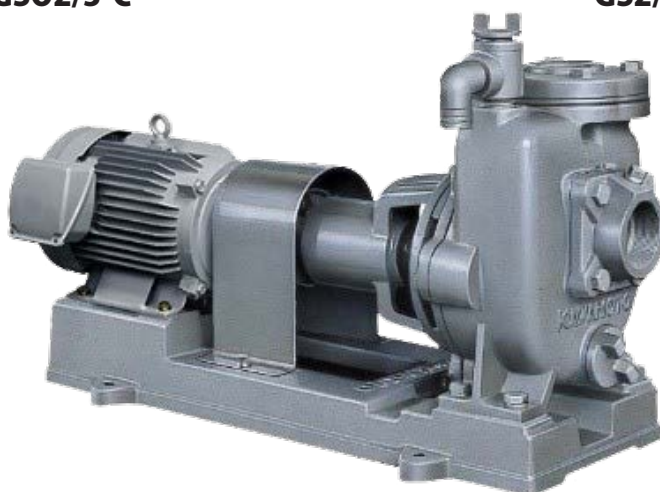

GS-M

GS-M BORE SIZE 40~100MM

APPLICATIONS AND FEATURES

■ APPLICATIONS

- Self priming type
- Cooling water
- Industry
- Agriculture
- General lift up water

■ FEATURES

- Self-priming pump construction does not require foot valve.
- Various kind of models.
- Easy maintenance and inspection due to back pull out construction.
- Low operation sound.

STANDARD SPECIFICATIONS

Description		Model : GS-M
Applicable Liquid		Clean water
Liquid Temperature		0 ~ 40 °C (however there should be no freezing)
Main Pump	Casing	Cast Iron
	Impeller	Cast Iron (Closed)
	Shaft	SUS403
Motor	Speed	2900 rpm
	Protection	IP55, TEFC
Construction	Shaft Seal	Packing seal (Non asbestos)

OPTIONAL SPECIFICATIONS

Description		Model : GS-M
Applicable Liquid		Clean water
Liquid Temperature		0 ~ 40 °C (however there should be no freezing)
Main Pump	Casing	Cast Iron
	Impeller	Bronze (Closed)
	Shaft	SUS304
Motor	Speed	2900 rpm
	Protection	IP55, TEFC
Construction	Shaft Seal	Packing seal (Non asbestos)

PERFORMANCE CHART (GS-M)

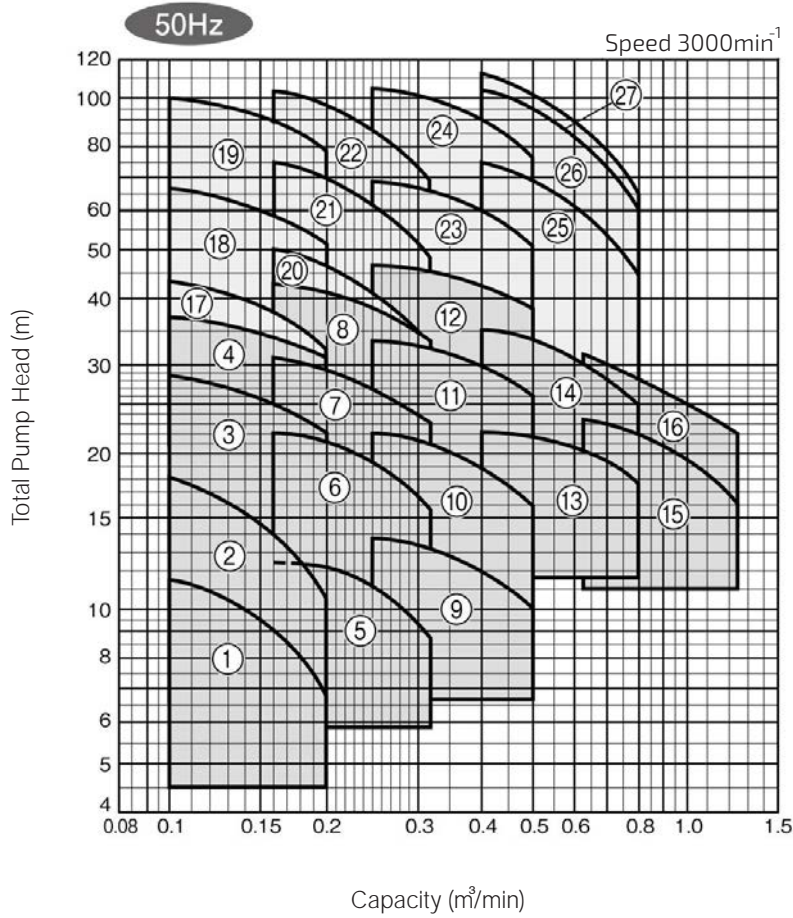

MODEL CODE

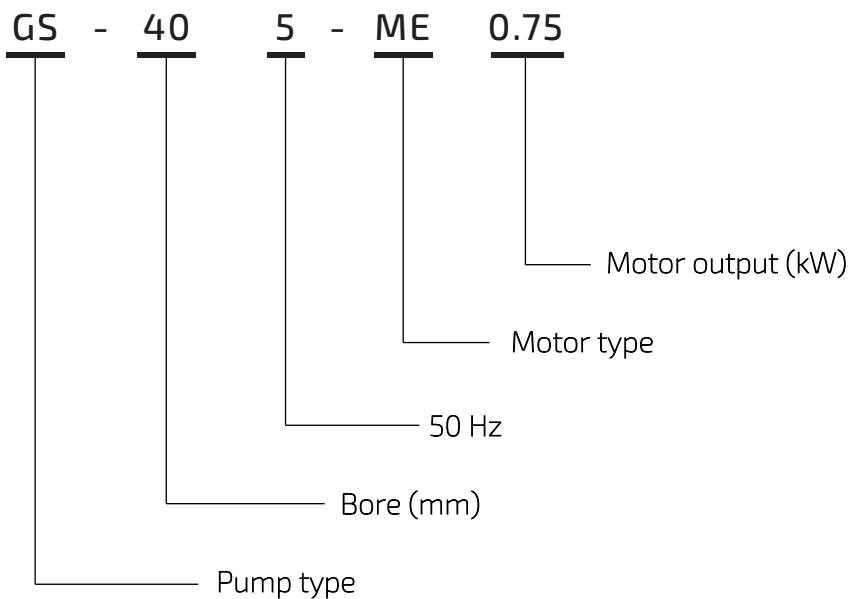

SPECIFICATION TABLE

No.	Bore (mm)	Model	Motor (kW)	Performance					
				Capacity (m ³ /min)	Total Head (m)	Capacity (m ³ /min)	Total Head (m)	Capacity (m ³ /min)	Total Head (m)
1	40	GS-405-MN0.4	0.4	0.1	11.5	0.14	10	0.2	6.8
2		GS405ME0.75	0.75	0.1	18	0.14	15.5	0.2	10.5
3		GS405ME1.5	1.5	0.1	28.5	0.14	26.5	0.2	22
4		GS405ME2.2	2.2	0.1	37	0.14	35	0.2	30.5
5	50	GS505ME0.75	0.75	0.16	12.5	0.22	11.8	0.32	8.8
6		GS505ME1.5	1.5	0.16	22.2	0.22	20.2	0.32	15.5
7		GS505ME2.2	2.2	0.16	31	0.22	28.5	0.32	23
8		GS505ME3.7	3.7	0.16	43	0.22	40	0.32	33.5
9	65	GS655ME1.5	1.5	0.25	13.8	0.36	12.5	0.5	10
10		GS655ME2.2	2.2	0.25	22	0.36	20	0.5	15.8
11		GS655ME3.7	3.7	0.25	33.5	0.36	31.5	0.5	26
12		GS655ME5.5	5.5	0.25	47	0.36	44.5	0.5	38.5
13	80	GS805ME3.7	3.7	0.4	22	0.56	21	0.8	17.5
14		GS805ME5.5	5.5	0.4	35.5	0.56	32	0.8	25
15	100	GS1005ME5.5	5.5	0.63	23.5	0.9	20.5	1.25	16
16		GS1005ME7.5	7.5	0.63	31	0.9	27	1.25	22

SECTION DRAWING

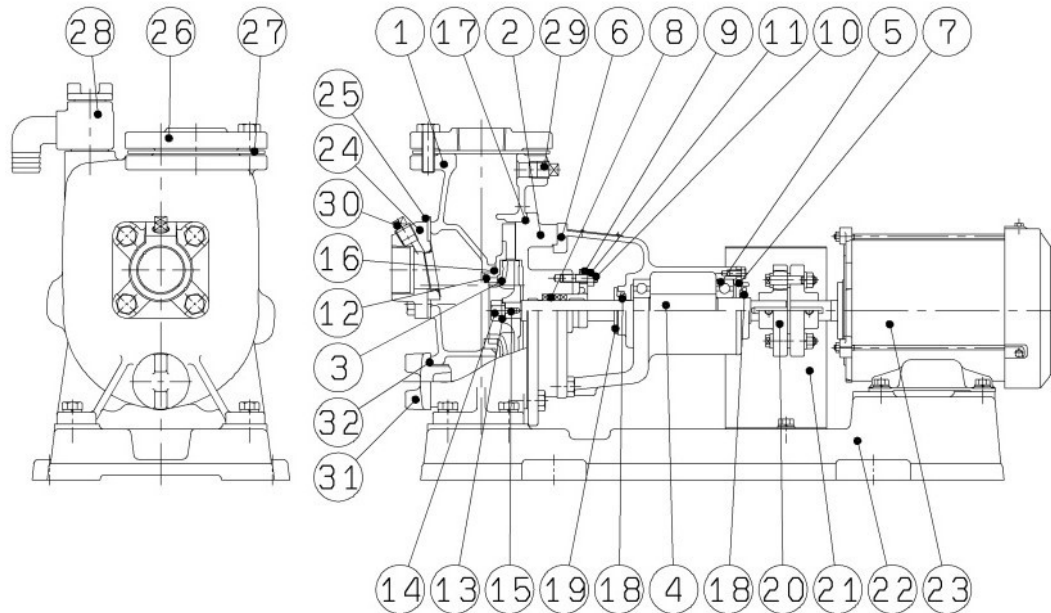

No.	Part name	Material	No.	Part name	Material
1	Casing	Cast iron	17	O-Ring	Rubber
2	Casing cover	Cast iron	18	Deflector	Rubber
3	Impeller	Cast iron	19	Deflector	Rubber
4	Shaft	SUS403	20	Coupling	Cast iron
5	Bearing	-	21	Coupling guard	SPCC
6	Bearing box	Cast iron	22	Base plate	Cast iron
7	Bearing cover	Cast iron	23	Motor	-
8	Gland packing	-	24	Flange	Cast iron
9	Packing gland	Bronze	25	Check valve	Rubber
10	Double end stud bolt	C3604	26	Flange	Cast iron
11	Nut	C3604	27	Flange packing	Rubber
12	Guide vane	Cast iron	28	Exhaust valve	-
13	Washer	C1201	29	Plug	SWCH10K
14	Nut	C3604	30	Plug	SWCH10K
15	Key	SUS403	31	Plug	Plastic
16	O-Ring	Rubber	32	Ring packing	Rubber

PUMP DIMENSION

Unit:mm

Bore d	ST	DT
40	38	25
50	38	27
65	104	31
80	126	33
100	134	39

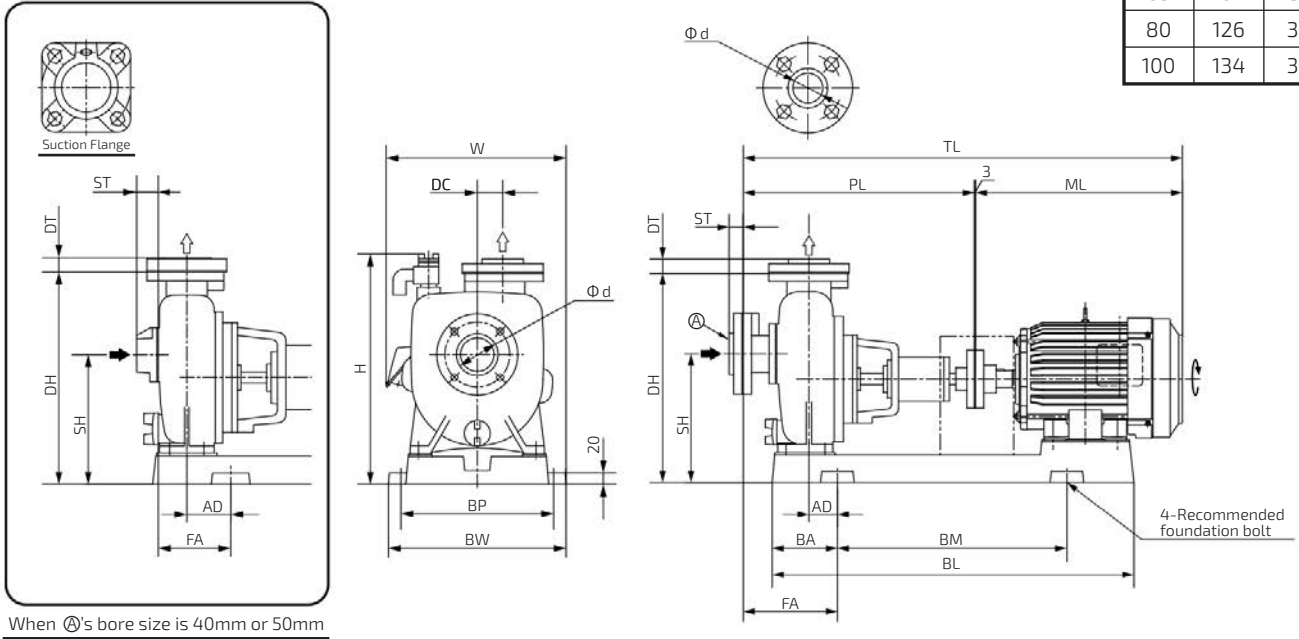

Bore (mm)	Model	Motor (kW)	Pump		Base					Combination							Foundation Bolt	Weight (kg)	
			DC	PL	BL	BA	BM	BP	BW	H	DH	SH	TL	AD	FA	W			ML
40	GS-405-MN0.4	0.4	35	390	558	127	320	220	254	401	322	207	631	62	117	273	238	M12x160	42
	GS405ME0.75	0.75	35	390	576	127	320	220	254	396	322	207	655	62	117	272	262		48
	GS405ME1.5	1.5	50	428	668	137	400	250	284	412	372	227	743	77	127	300	312		62
	GS405ME2.2	2.2	50	404	689	137	400	310	344	437	395	240	719	77	127	-	312		86
50	GS505ME0.75	0.75	40	405	576	127	320	220	254	396	322	212	670	67	132	272	262	M12x160	50
	GS505ME1.5	1.5	40	405	626	107	400	250	284	396	322	212	720	47	112	300	312		54
	GS505ME2.2	2.2	50	438	668	137	400	250	284	412	372	232	753	82	137	300	312		71
	GS505ME3.7	3.7	50	418	689	137	400	310	344	459	417	267	802	82	137	353	381		91
65	GS655ME1.5	1.5	52	489	698	167	400	250	284	434	392	242	804	87	230	300	312	M16x200	77
	GS655ME2.2	2.2	52	489	698	167	400	250	284	434	392	242	804	87	230	300	312		81
	GS655ME3.7	3.7	55	503	750	172	400	310	354	497	455	280	887	92	235	358	381		115
	GS655ME5.5	5.5	55	503	788	142	500	340	384	497	455	280	957	62	205	389	451		131
80	GS805ME3.7	3.7	50	528	736	167	400	280	314	449	412	247	912	97	265	338	381	M16x200	96
	GS805ME5.5	5.5	50	588	862	177	500	340	384	512	475	285	1042	82	250	389	451		147
100	GS1005ME5.5	5.5	60	610	862	177	500	340	384	512	475	285	1064	87	272	389	451	M16x200	155
	GS1005ME7.5	7.5	60	610	862	177	500	340	384	512	475	295	1064	87	272	389	451		162

EXPECTED PERFORMANCE CURVE

MODEL : GS-405-MN0.4

■ PERFORMANCE CURVES

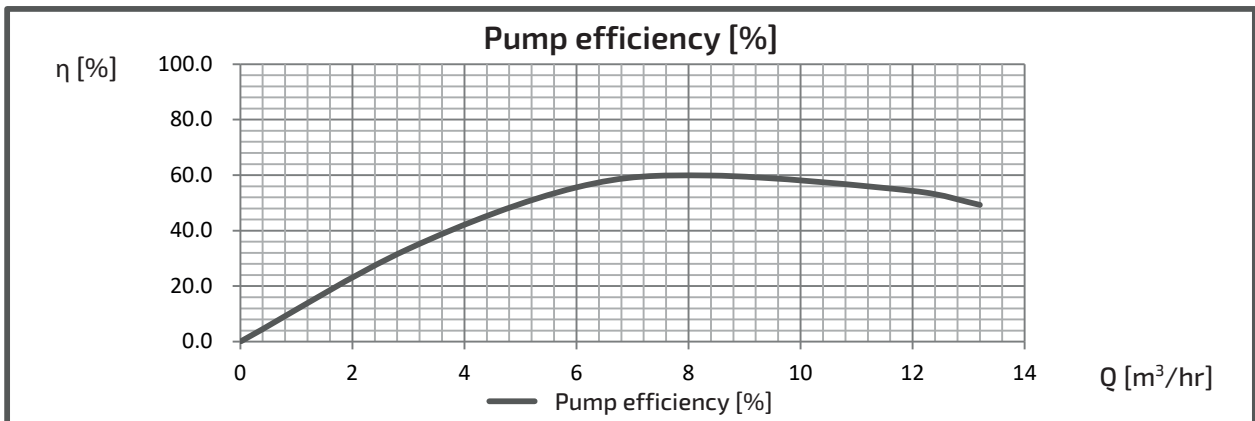
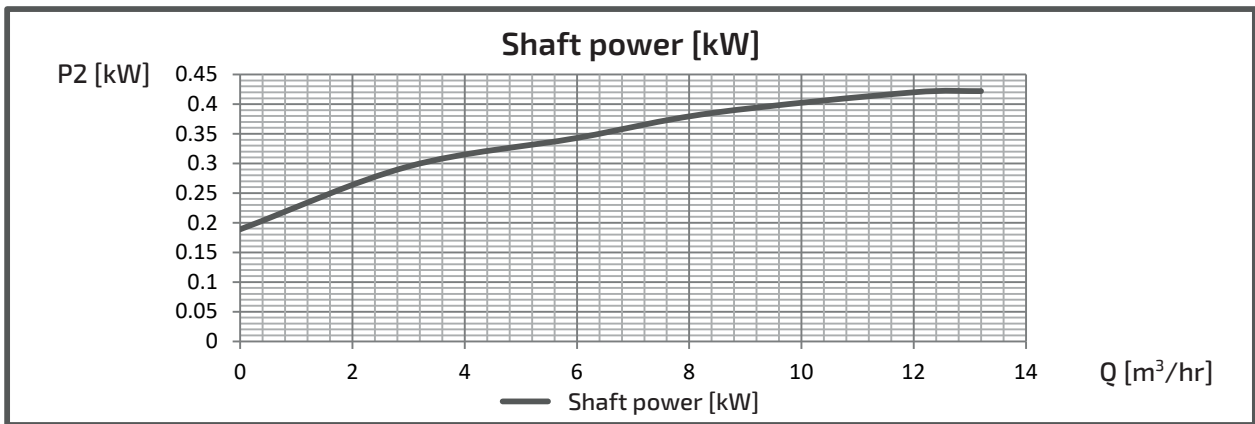
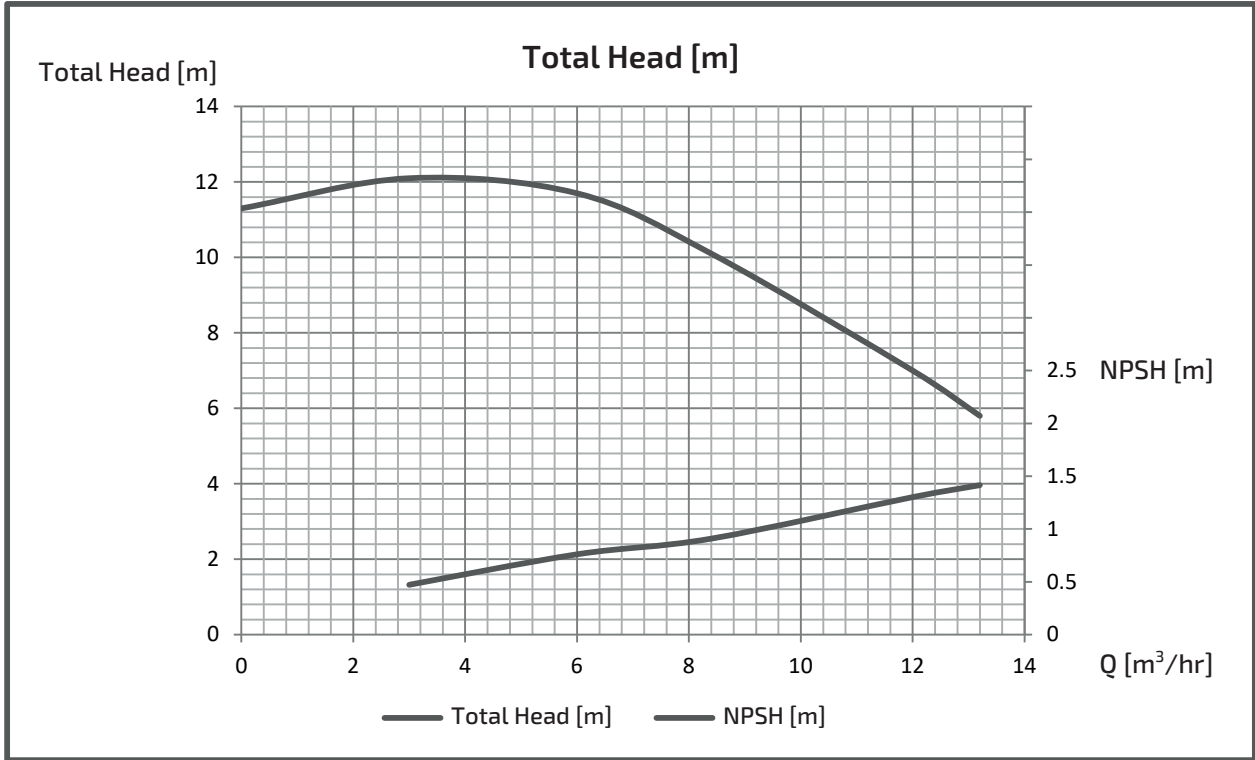

EXPECTED PERFORMANCE CURVE

MODEL : GS405ME0.75

■ PERFORMANCE CURVES

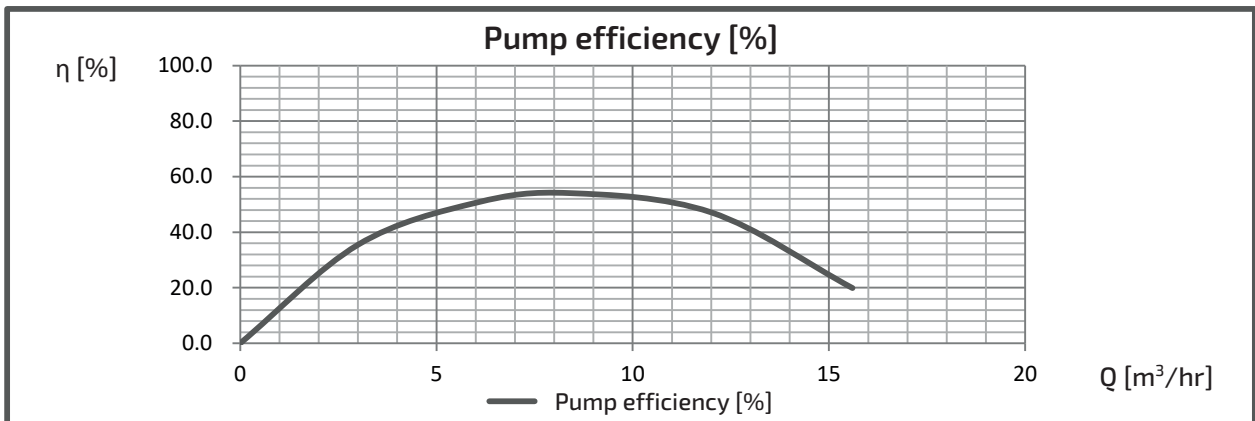
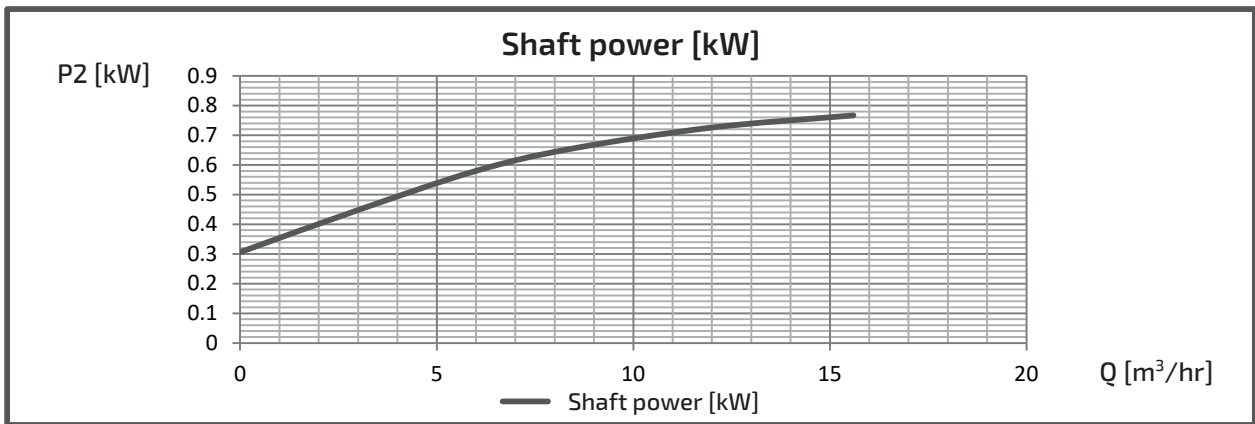
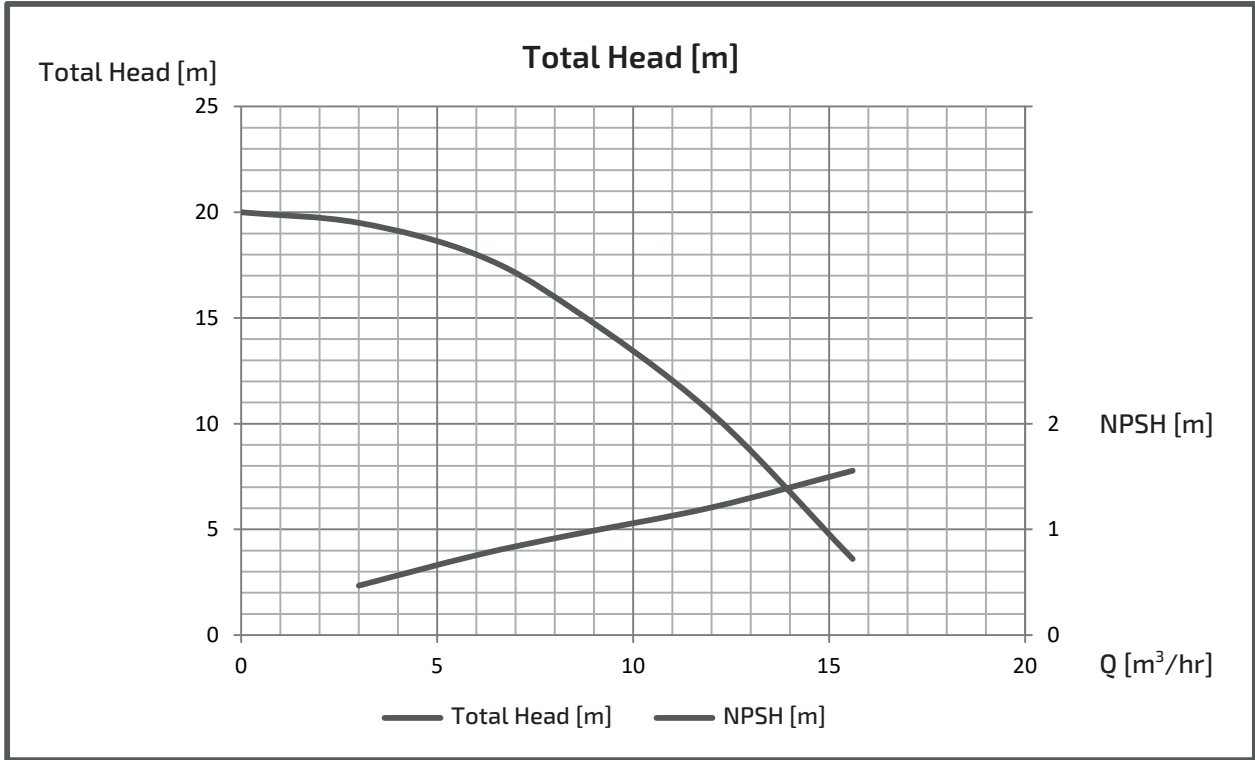

EXPECTED PERFORMANCE CURVE

MODEL : GS405ME1.5

■ PERFORMANCE CURVES

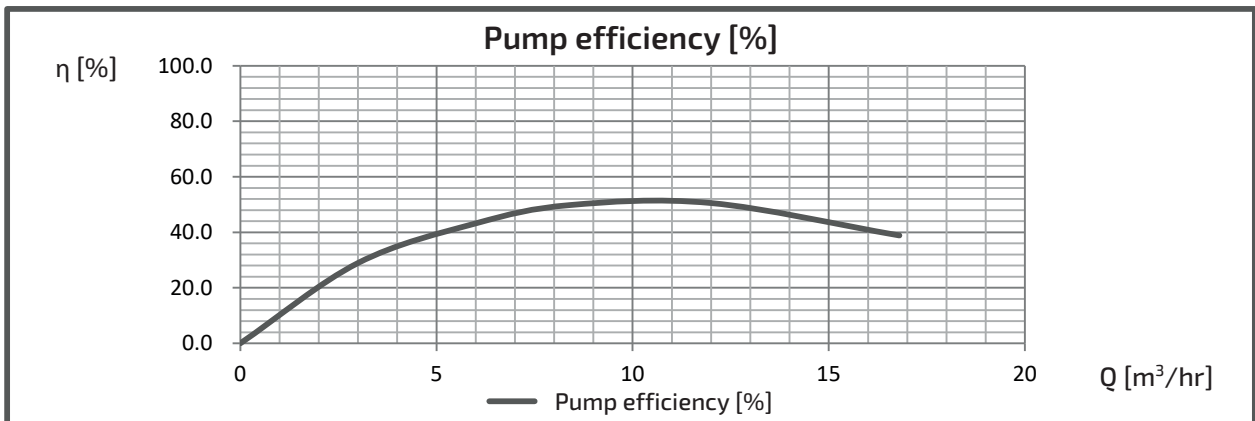
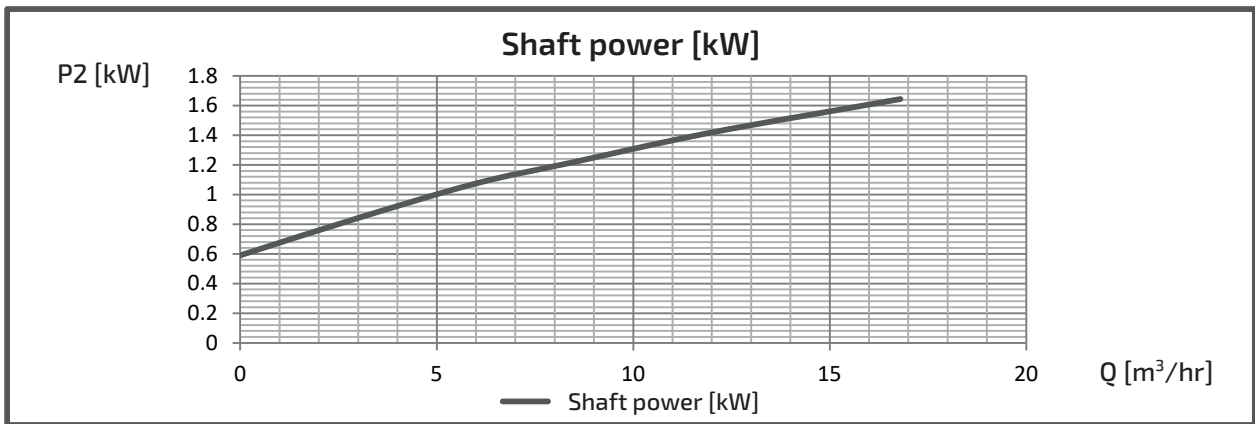
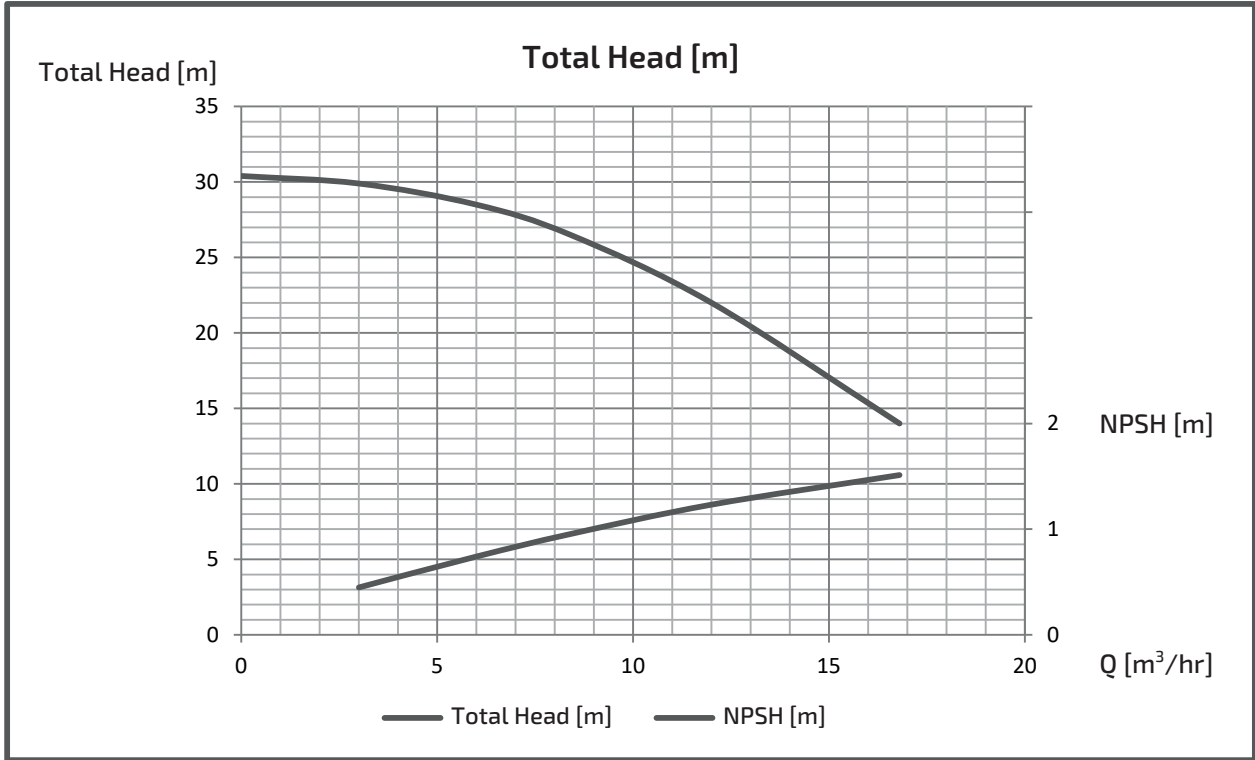

EXPECTED PERFORMANCE CURVE

MODEL : GS405ME2.2

■ PERFORMANCE CURVES

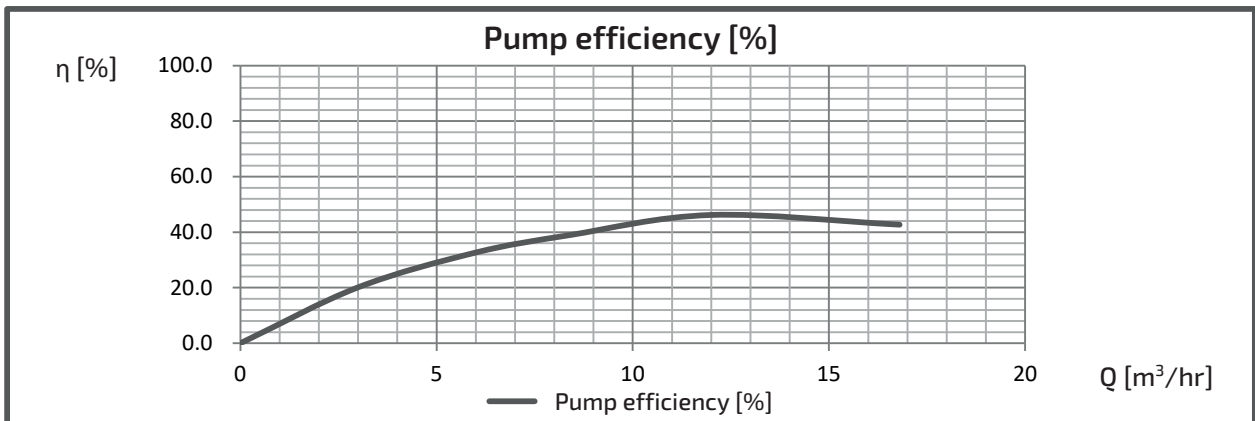
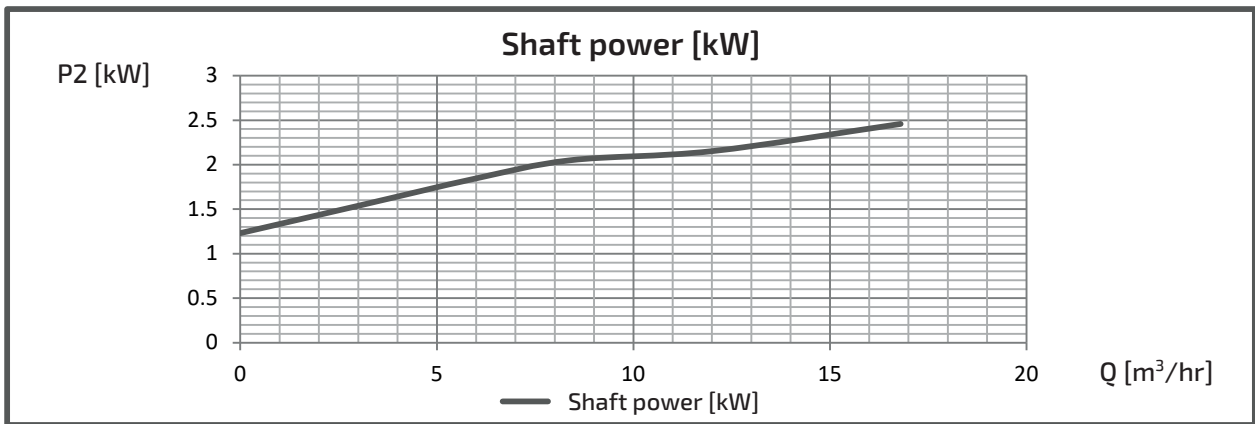
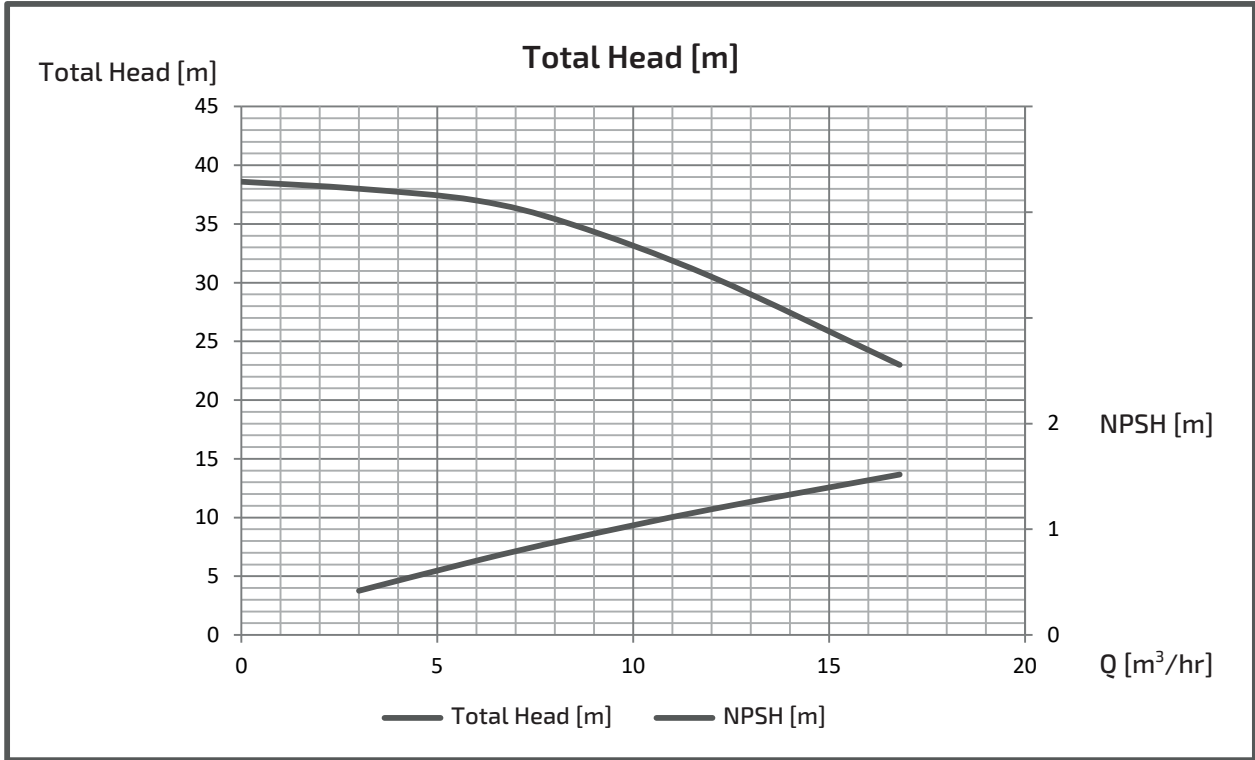

EXPECTED PERFORMANCE CURVE

MODEL : GS505ME0.75

■ PERFORMANCE CURVES

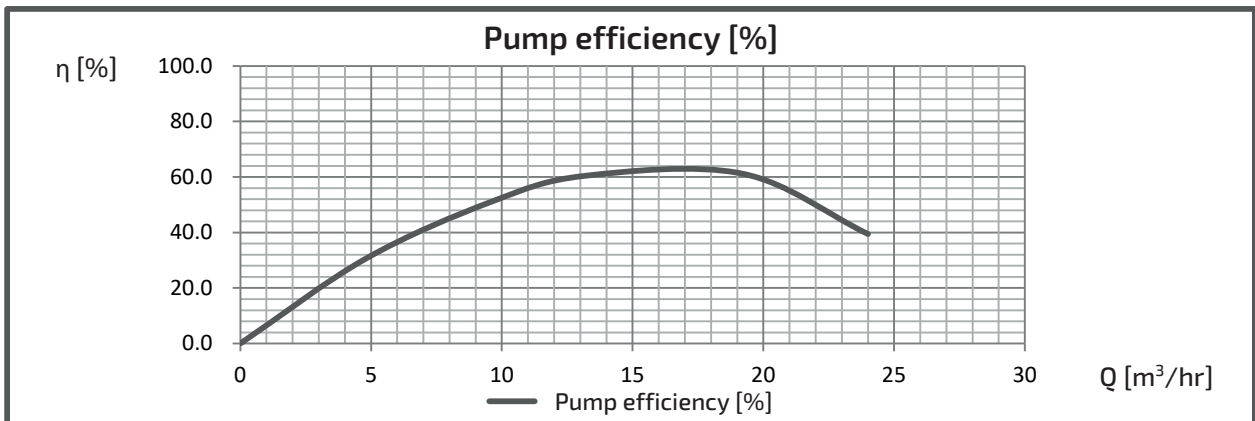
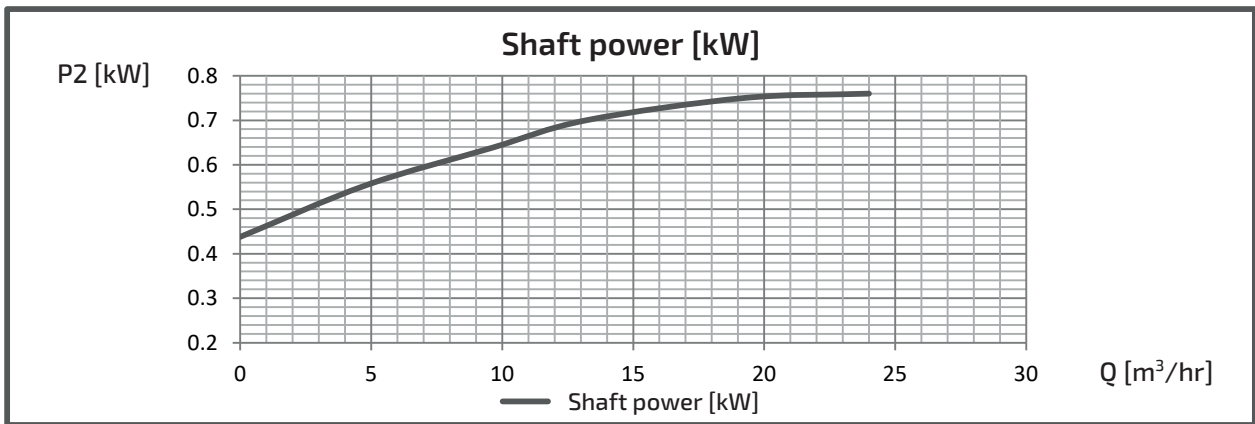
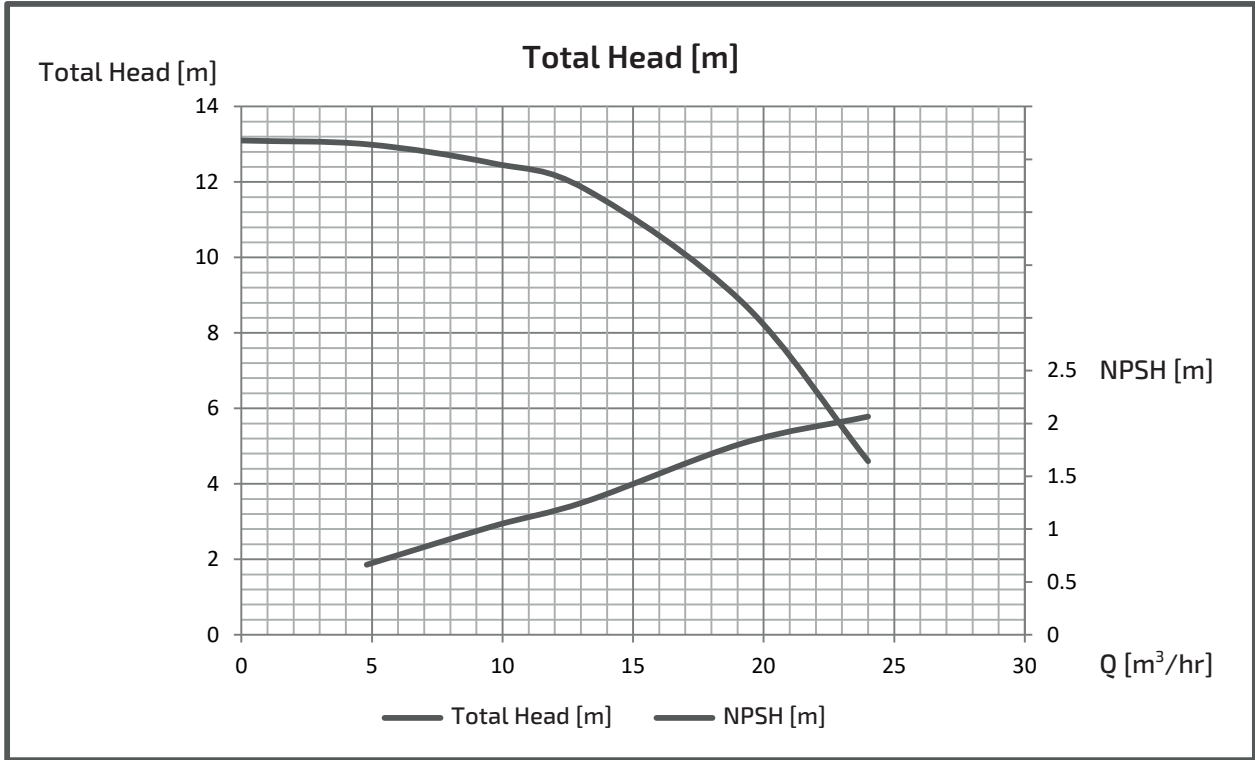

EXPECTED PERFORMANCE CURVE

MODEL : GS505ME1.5

■ PERFORMANCE CURVES

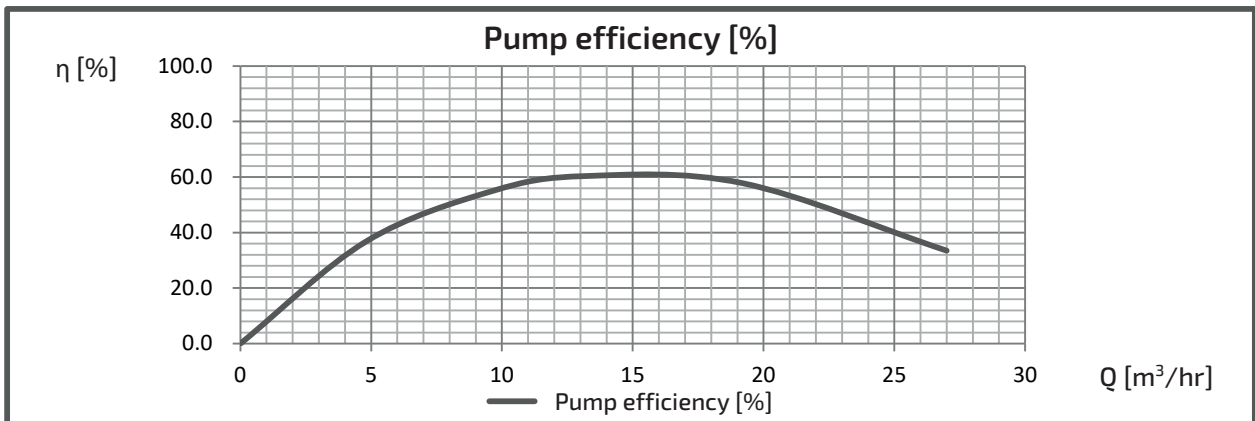
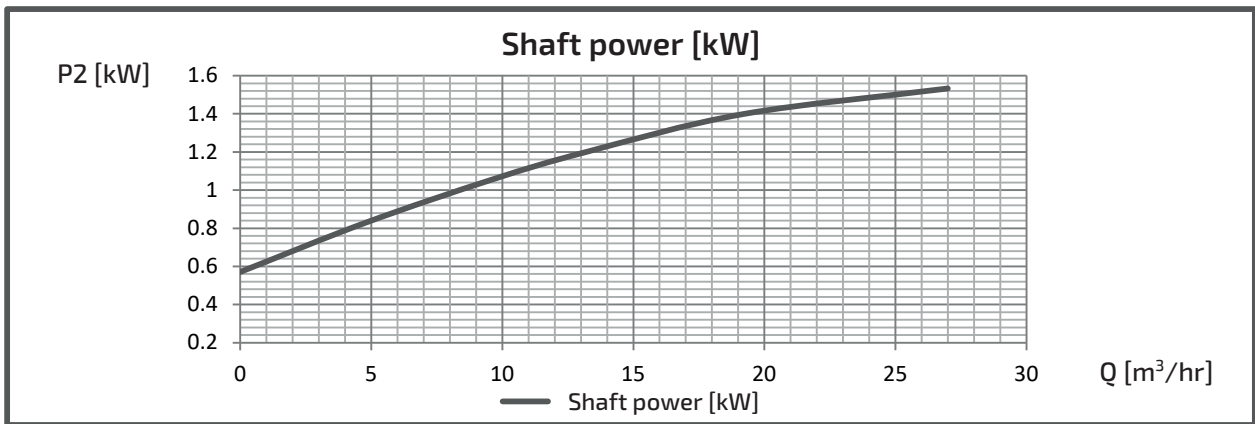
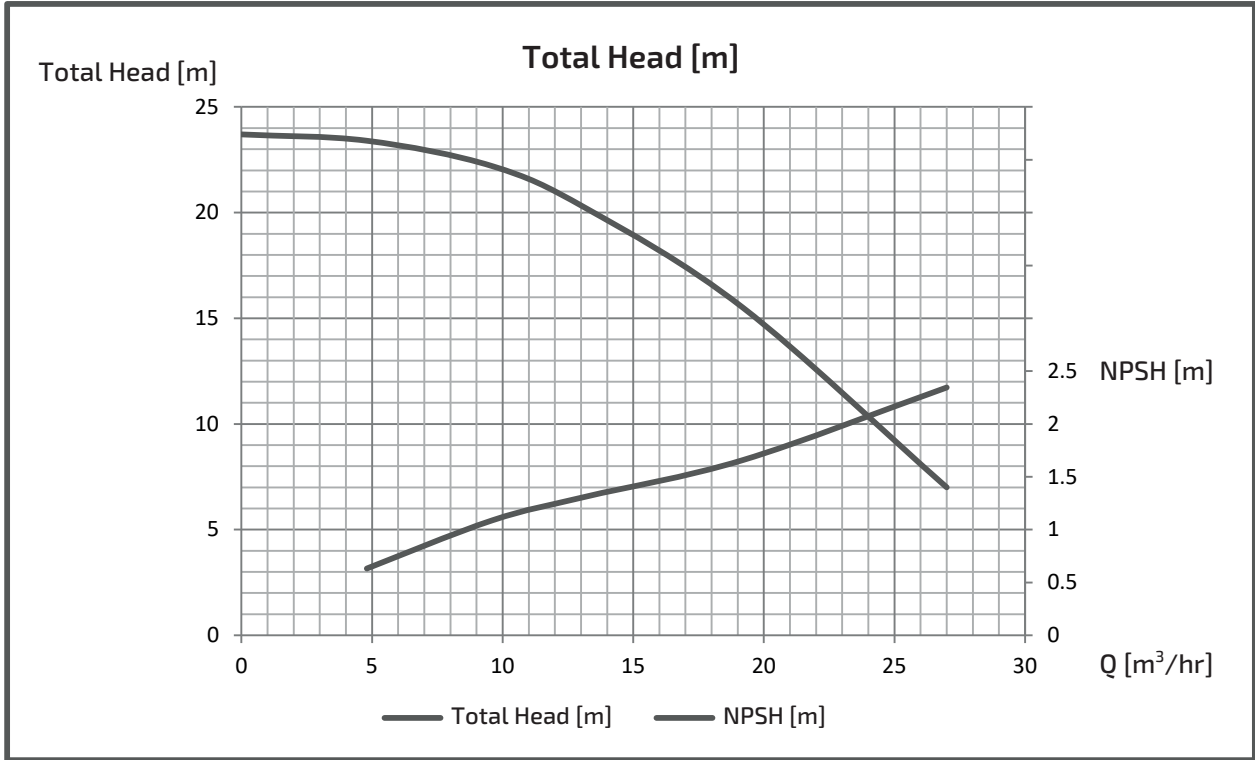

EXPECTED PERFORMANCE CURVE

MODEL : GS505ME2.2

■ PERFORMANCE CURVES

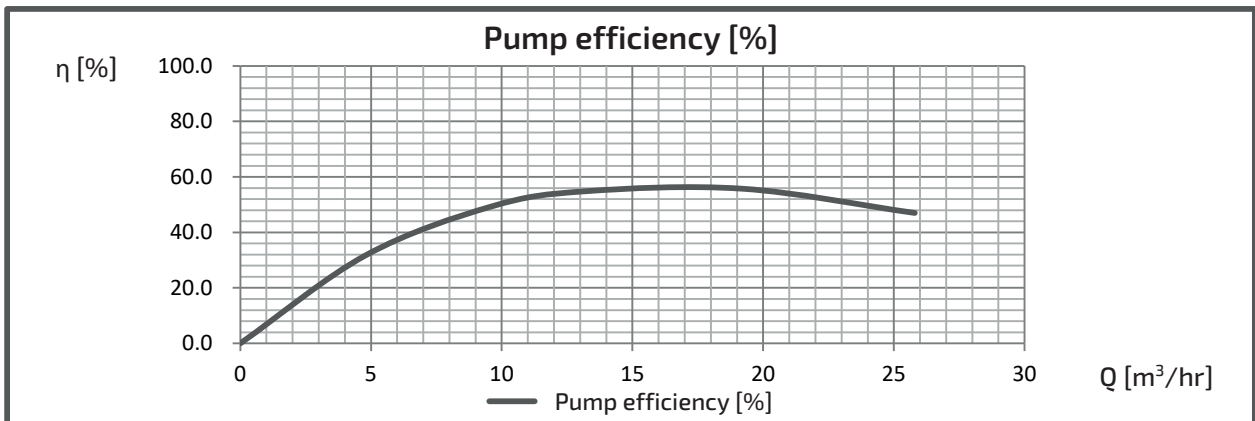
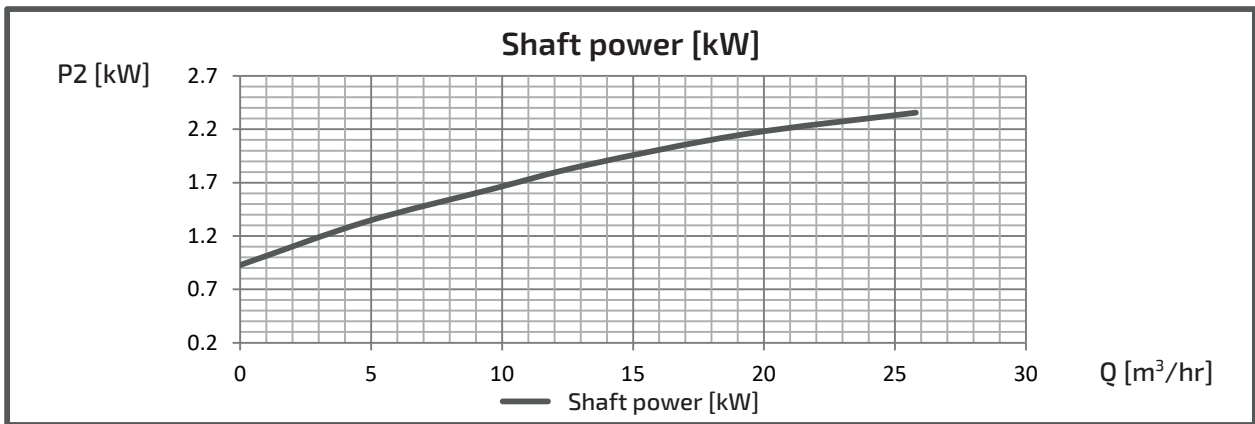
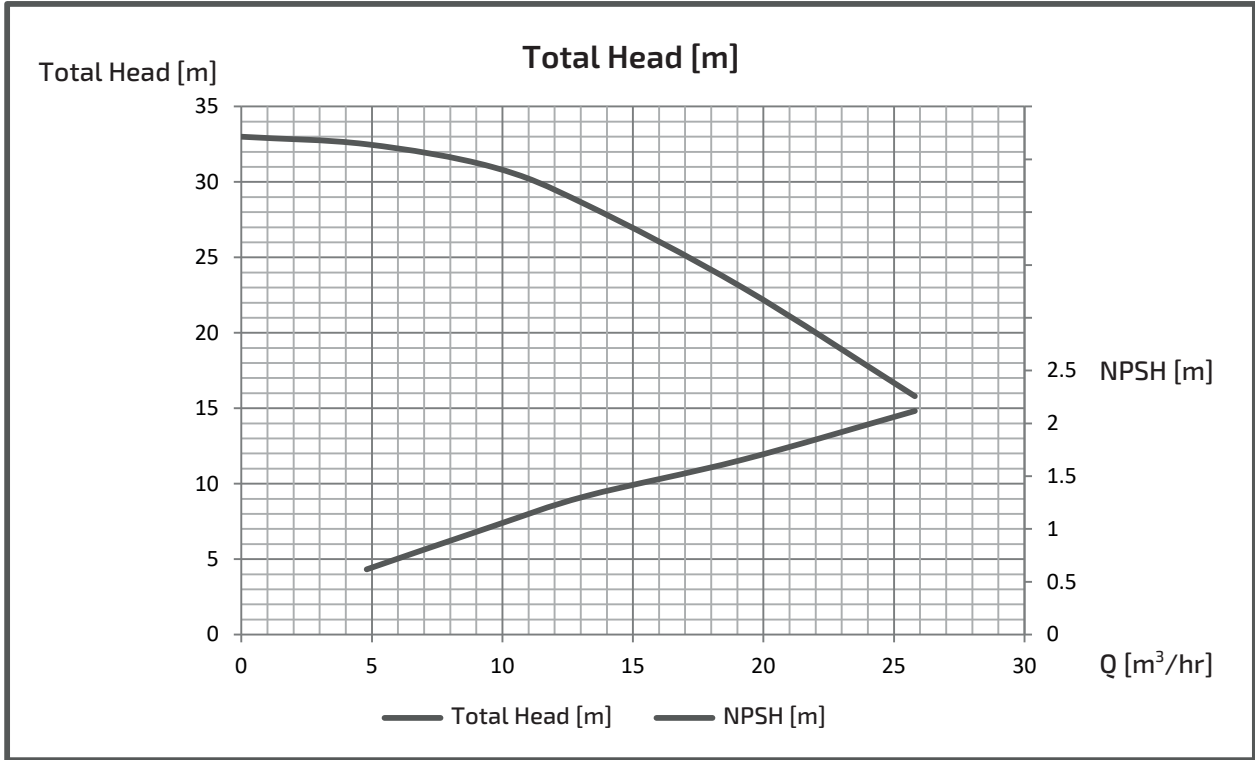

EXPECTED PERFORMANCE CURVE

MODEL : GS505ME3.7

■ PERFORMANCE CURVES

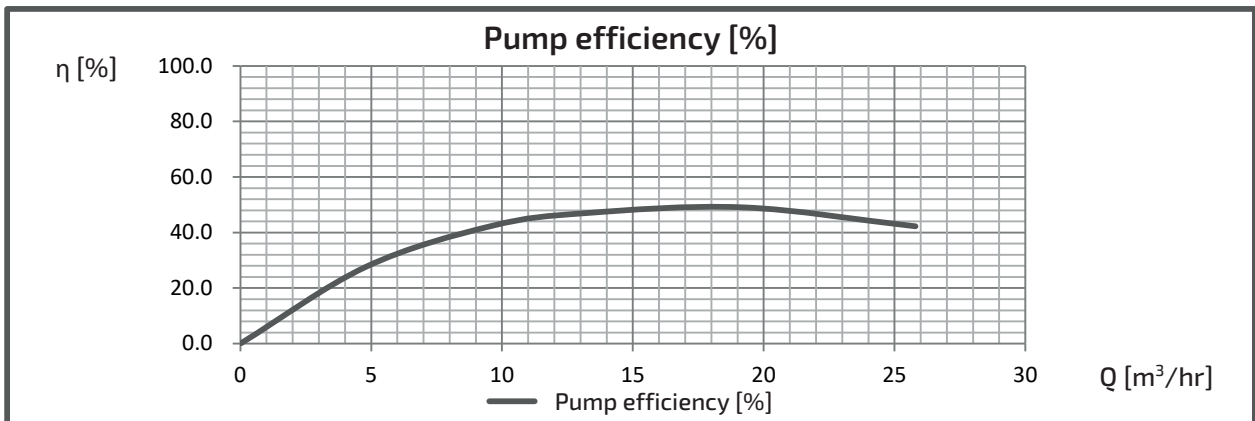
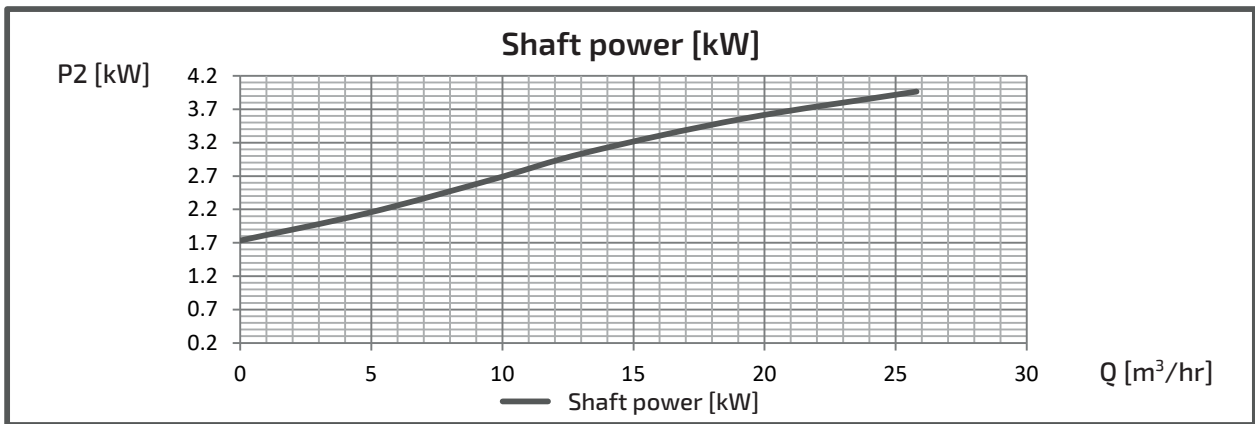
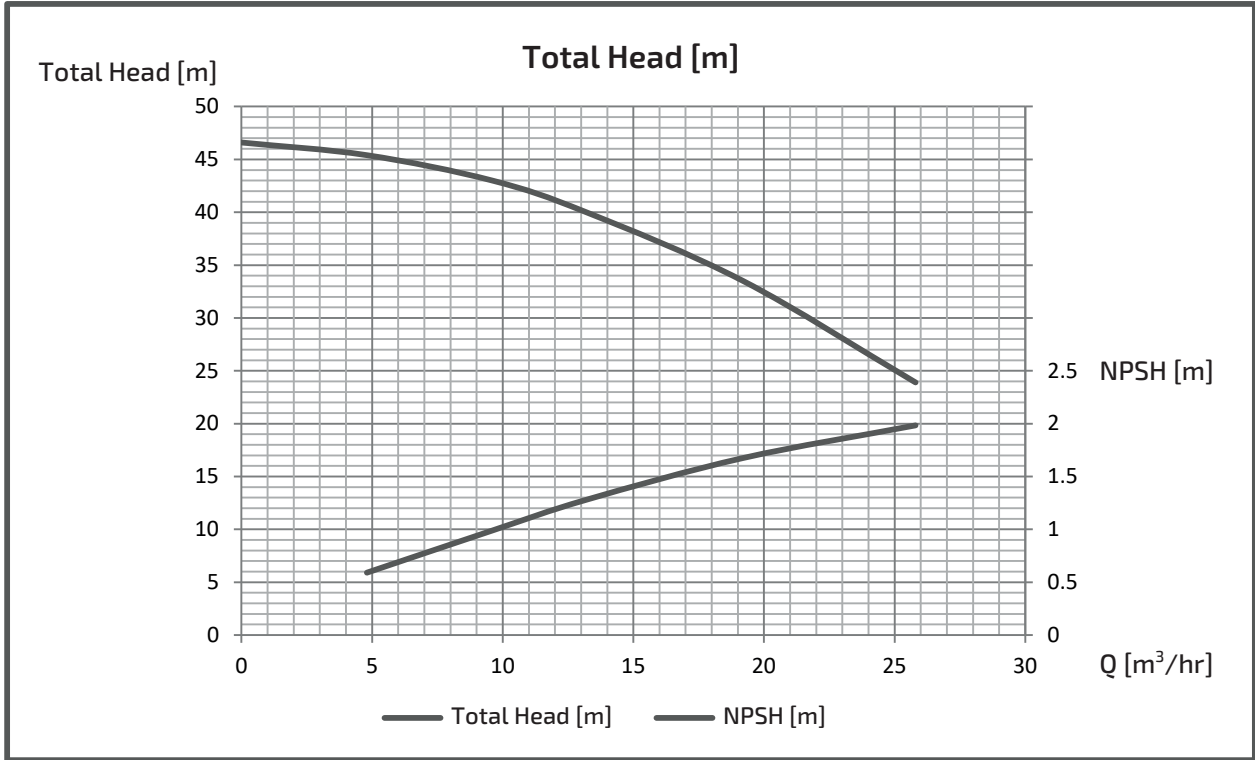

EXPECTED PERFORMANCE CURVE

MODEL : GS655ME1.5

■ PERFORMANCE CURVES

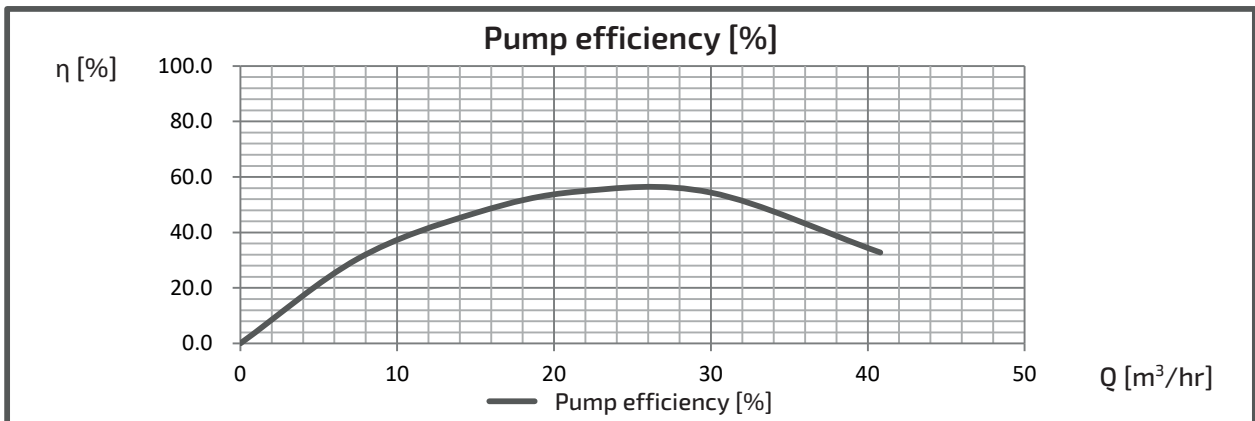
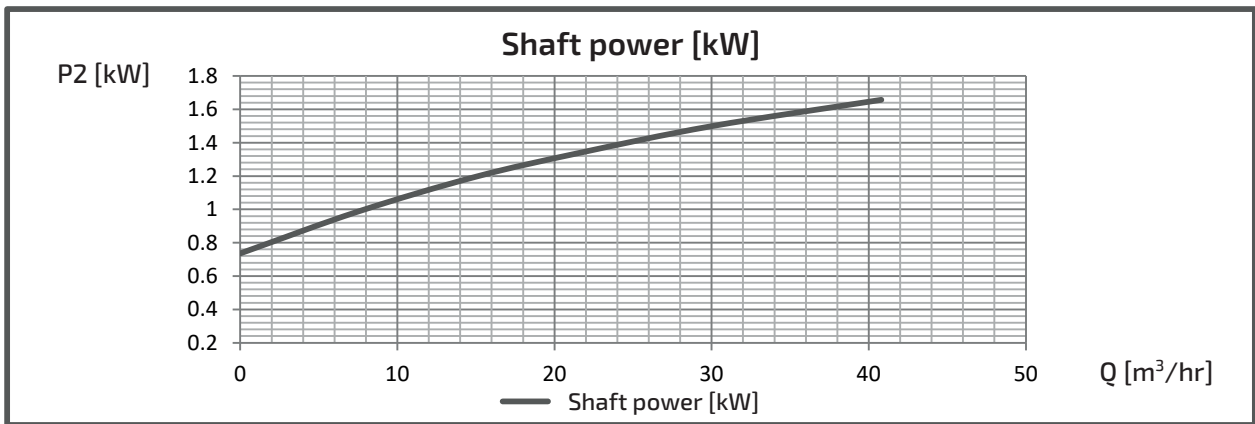
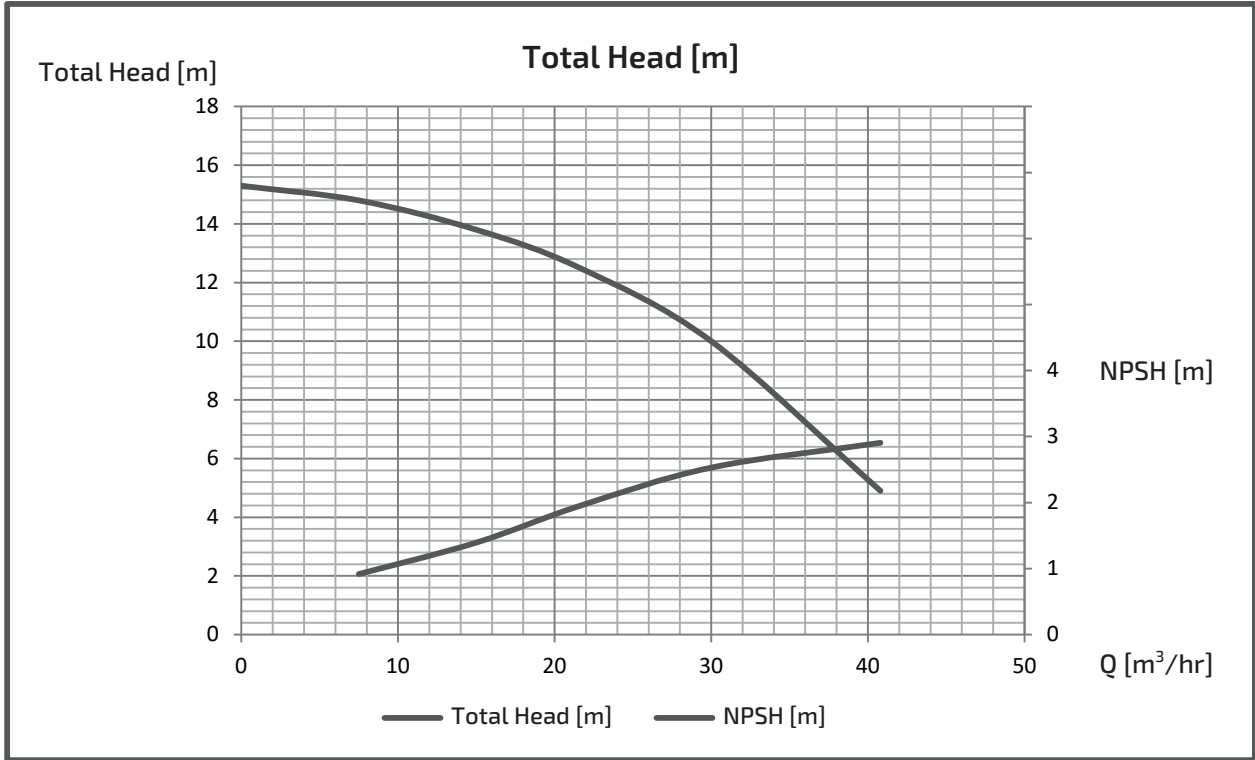

EXPECTED PERFORMANCE CURVE

MODEL : GS655ME2.2

■ PERFORMANCE CURVES

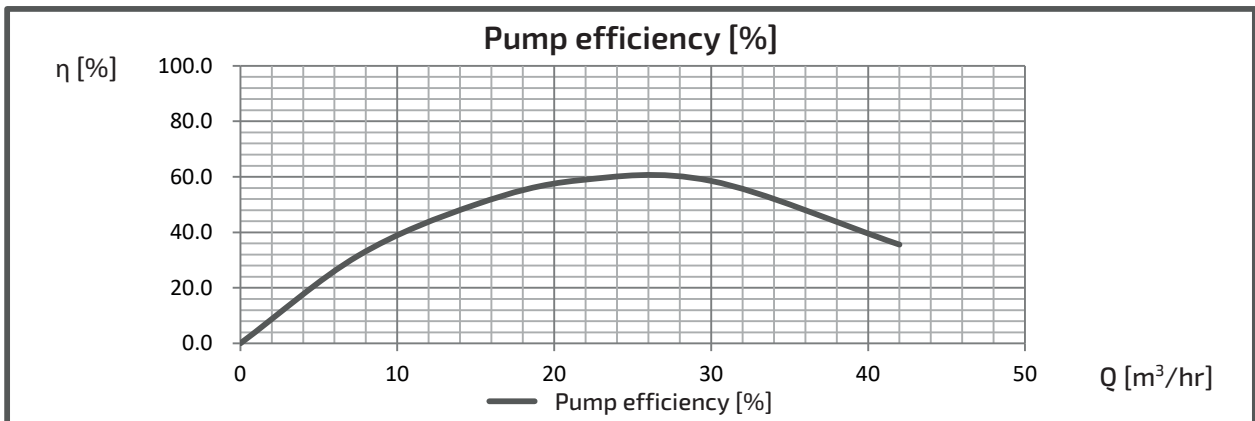
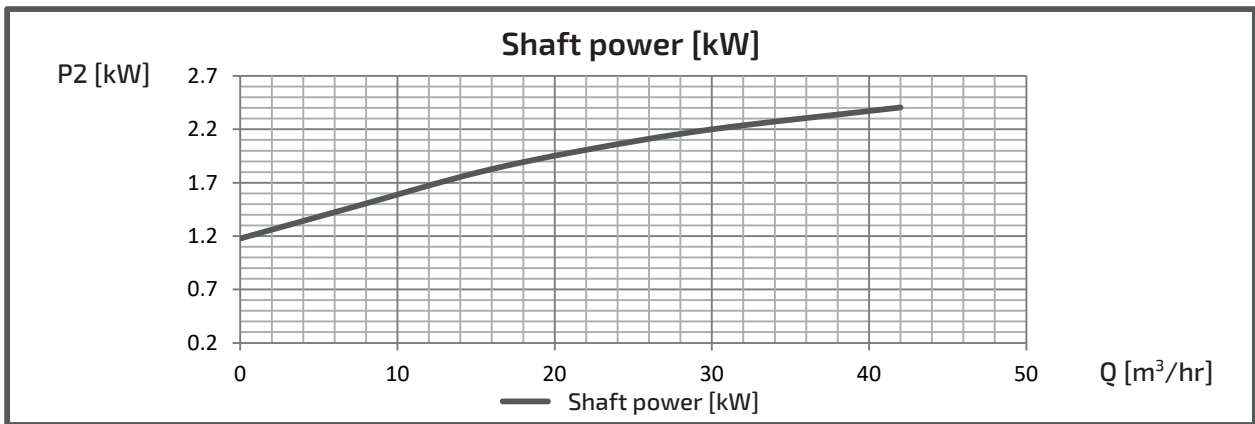
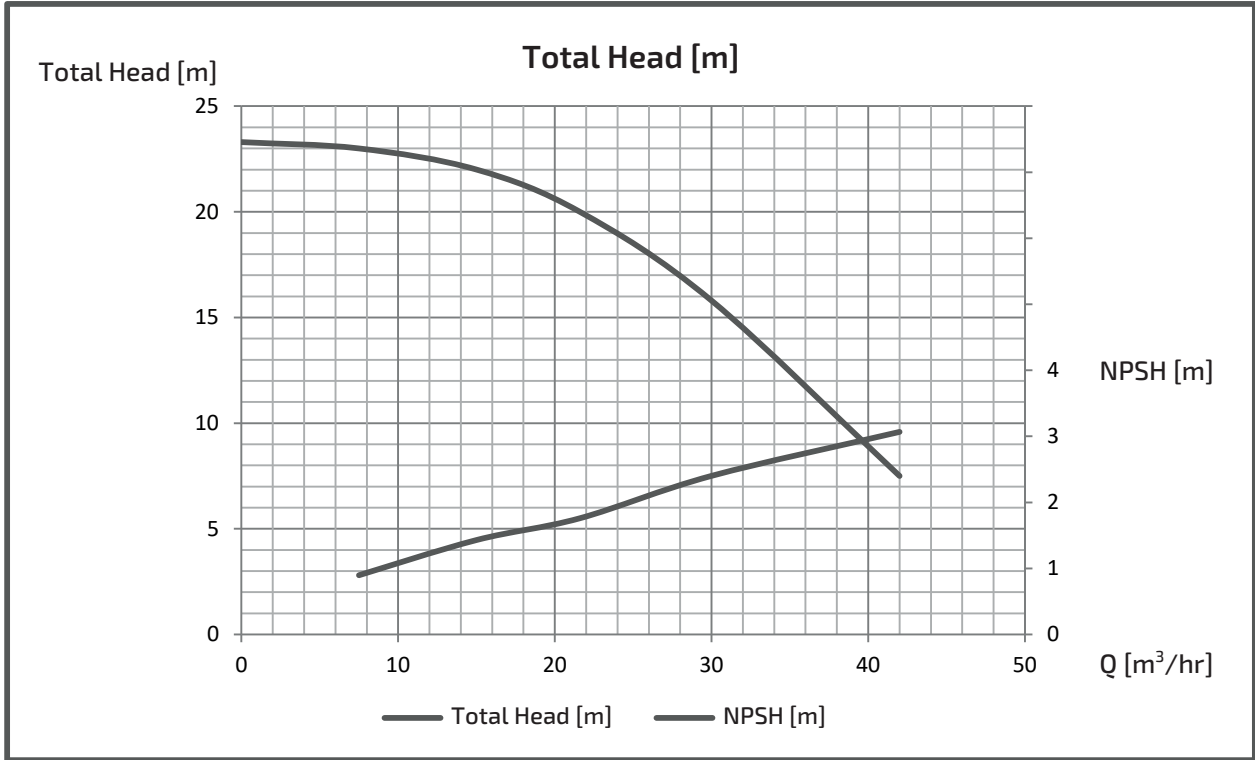

EXPECTED PERFORMANCE CURVE

MODEL : GS655ME3.7

■ PERFORMANCE CURVES

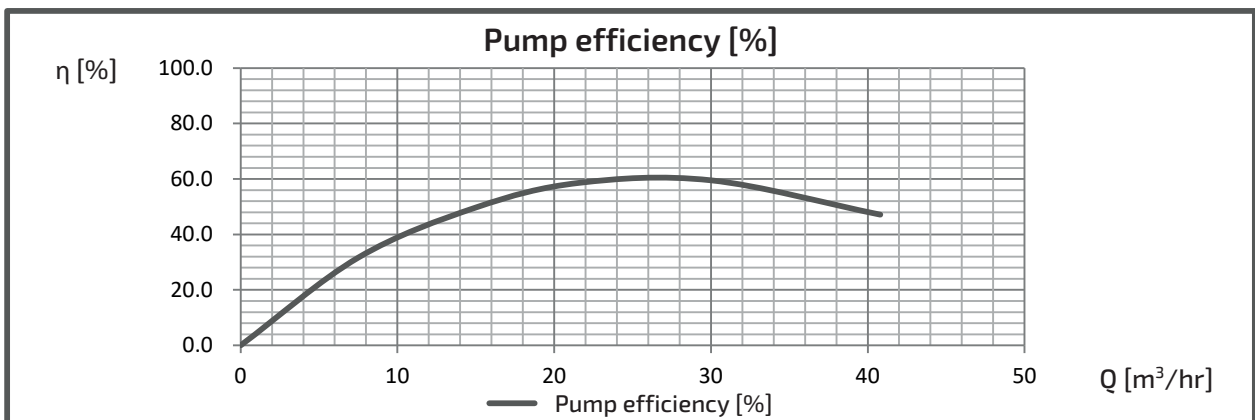
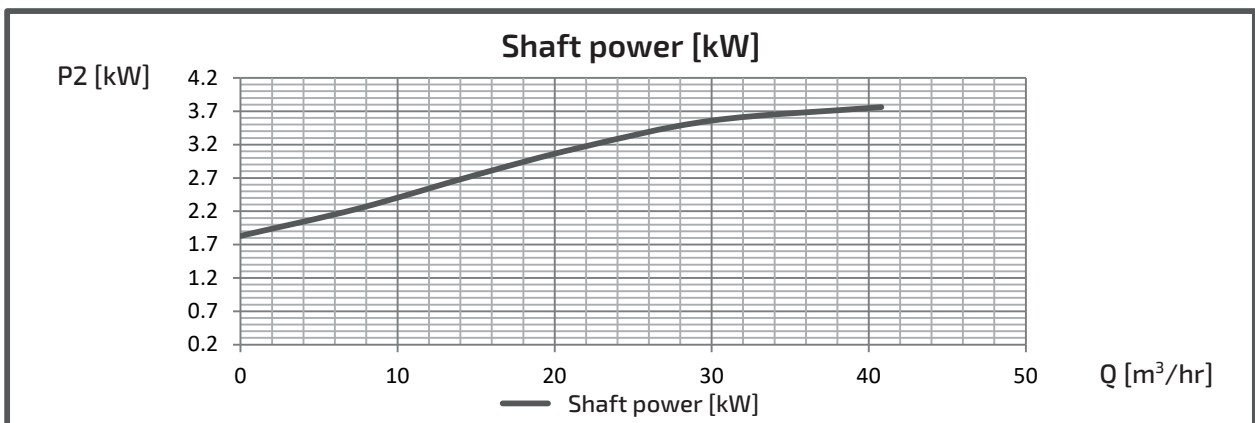
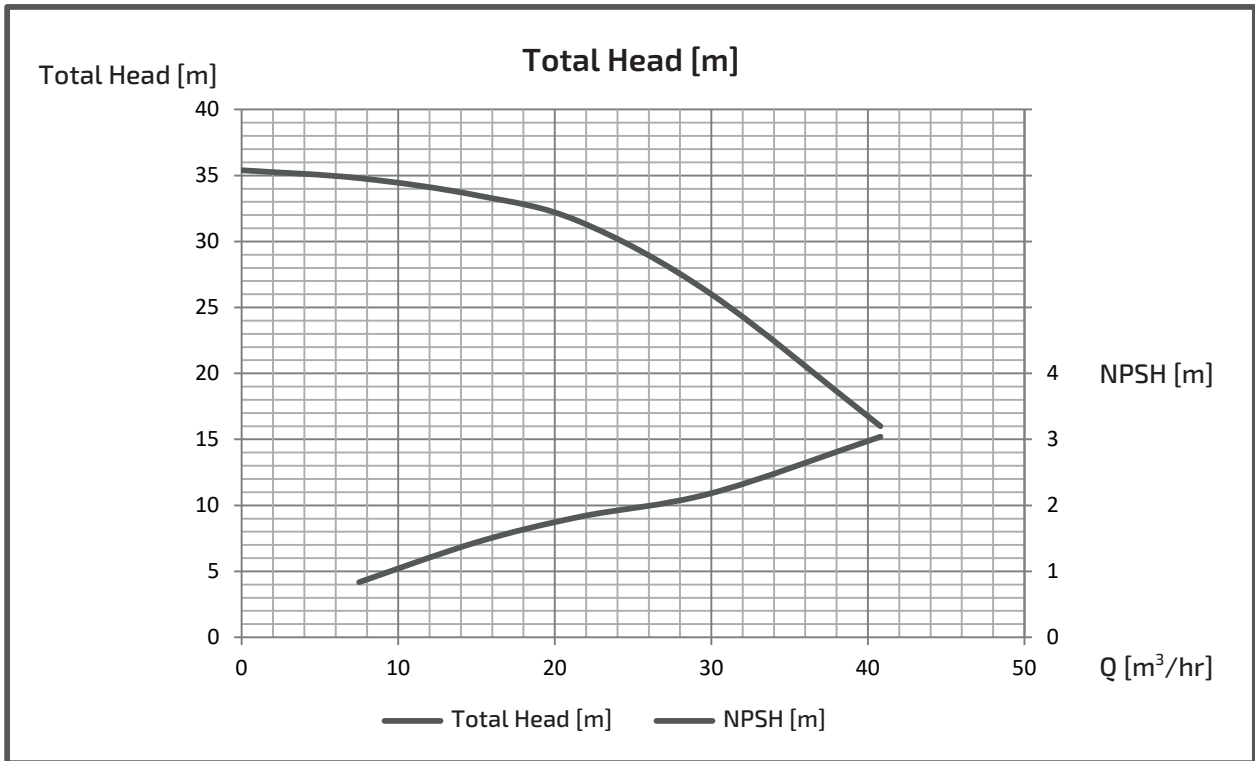

EXPECTED PERFORMANCE CURVE

MODEL : GS655ME5.5

■ PERFORMANCE CURVES

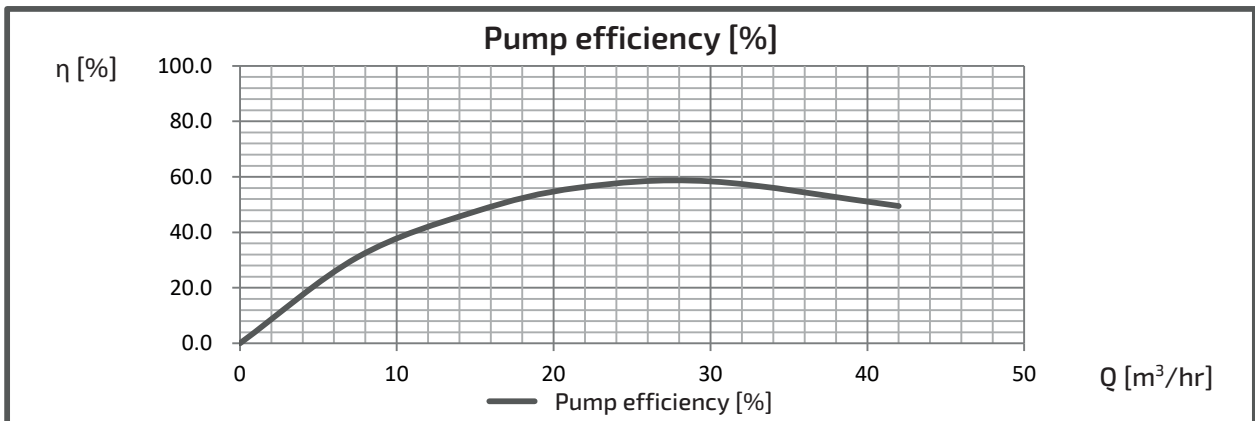
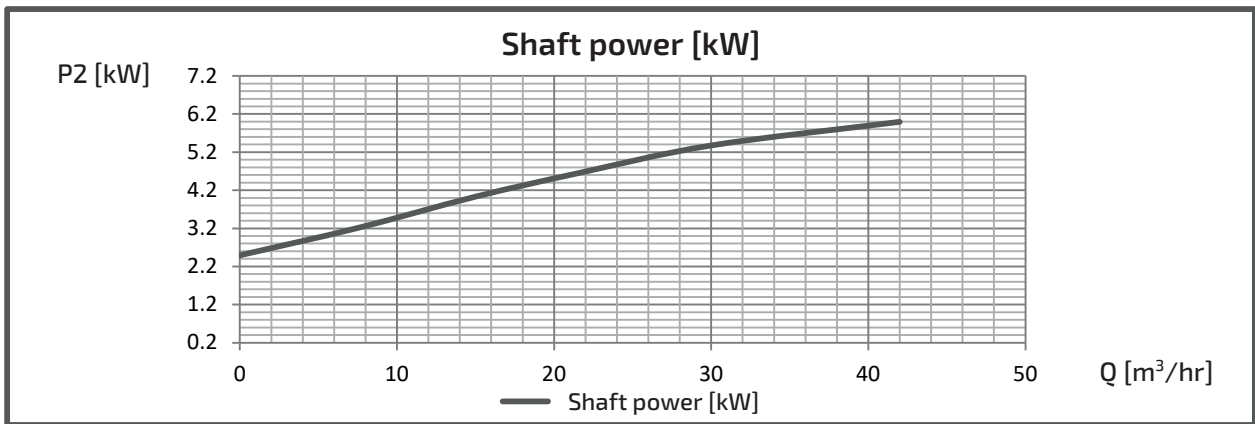
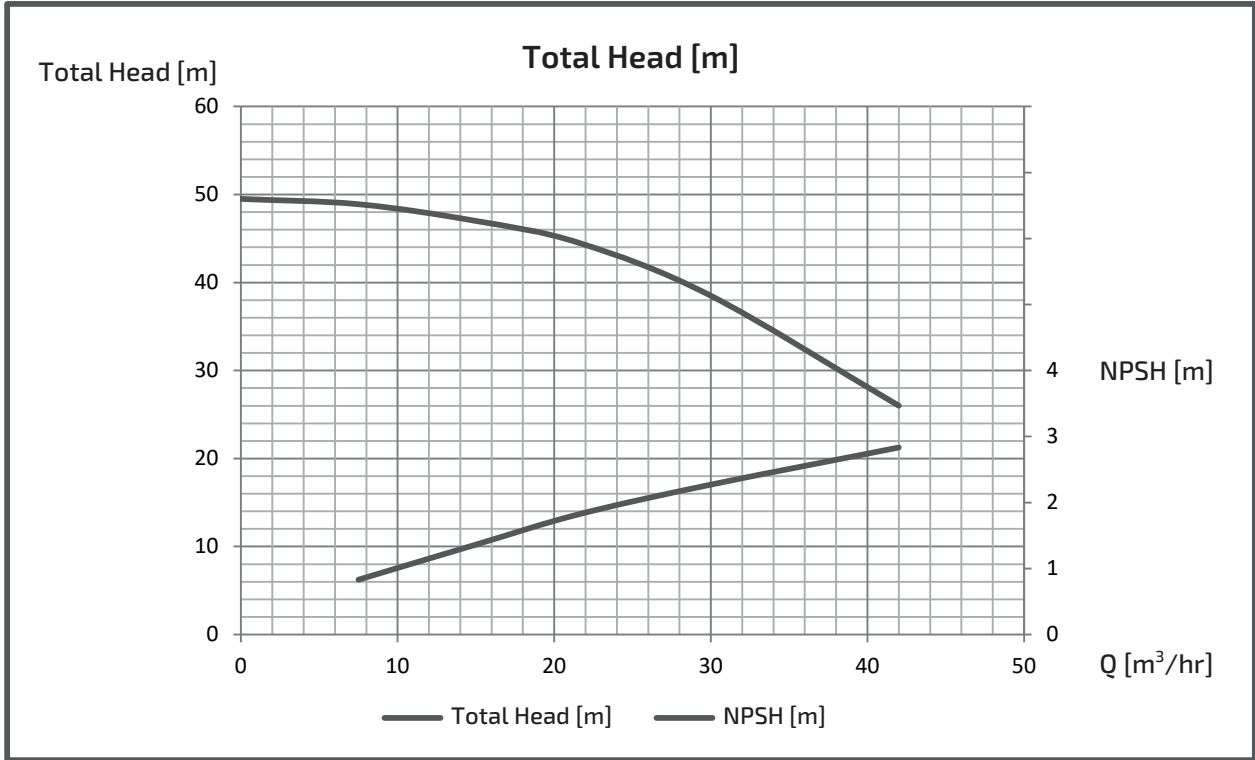

EXPECTED PERFORMANCE CURVE

MODEL : GS805ME3.7

■ PERFORMANCE CURVES

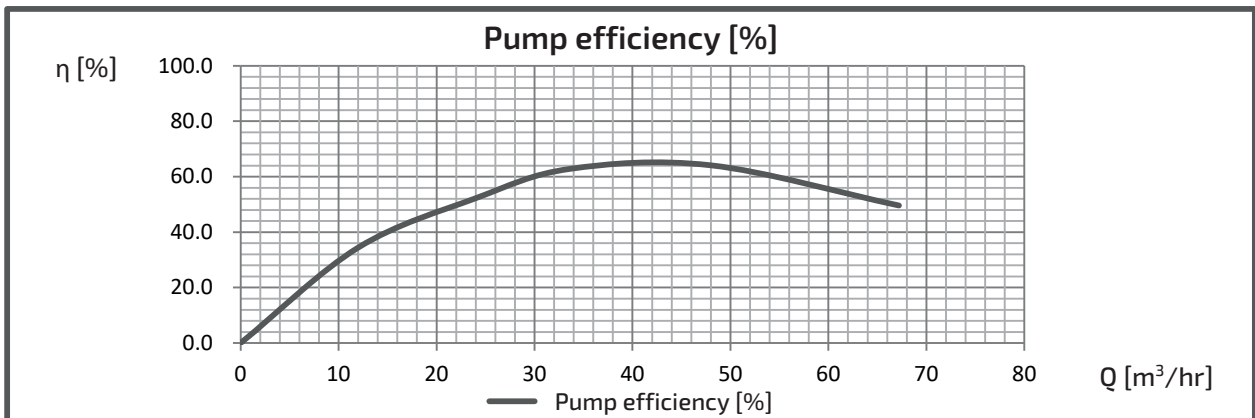
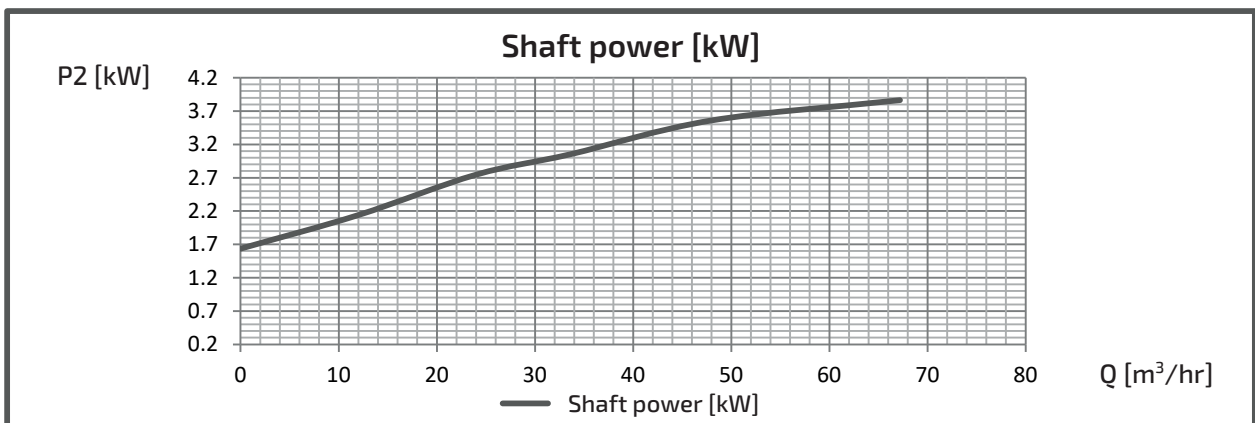
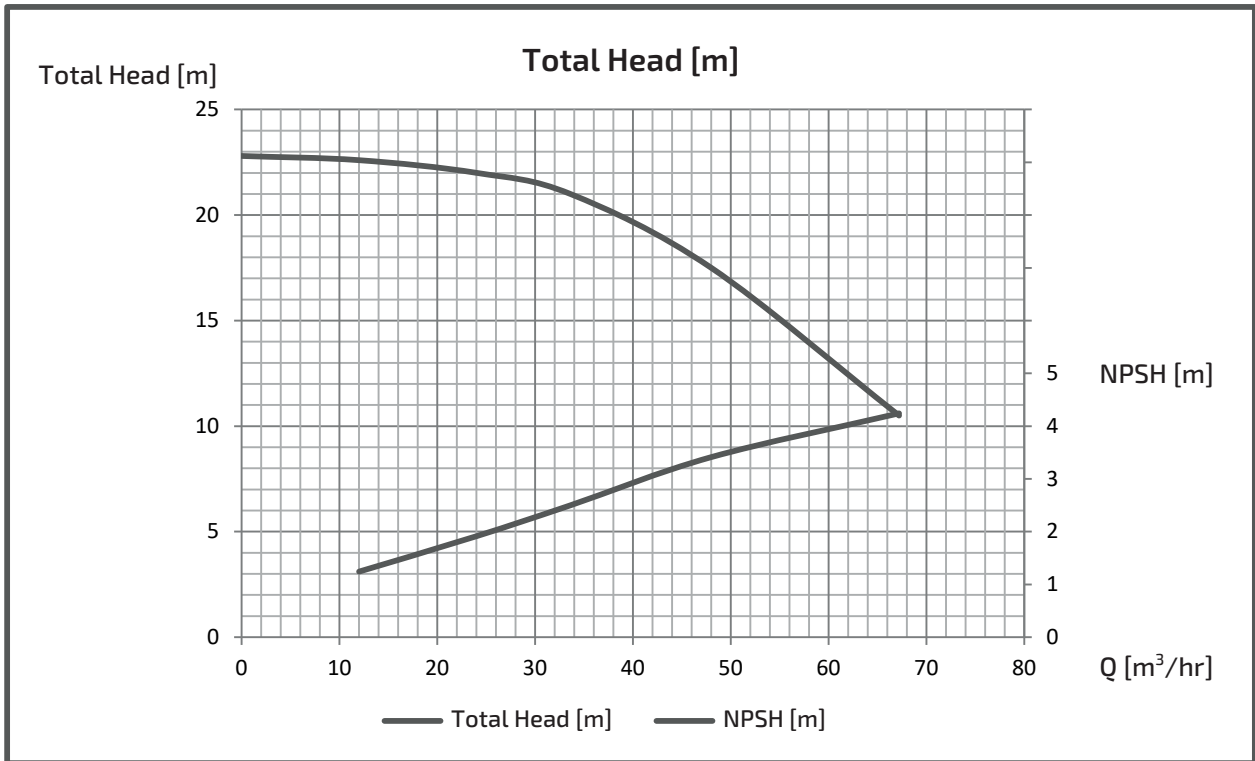

EXPECTED PERFORMANCE CURVE

MODEL : GS805ME5.5

■ PERFORMANCE CURVES

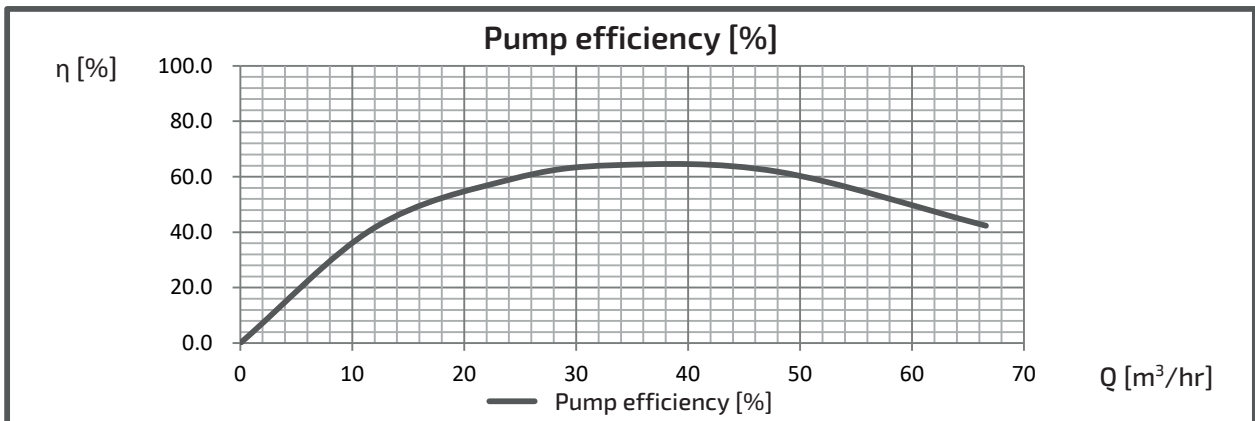
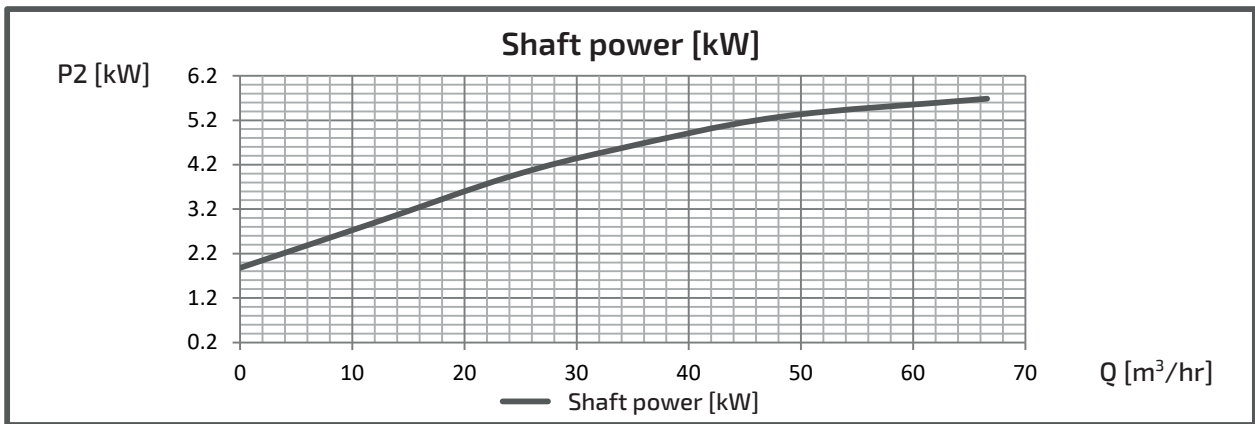
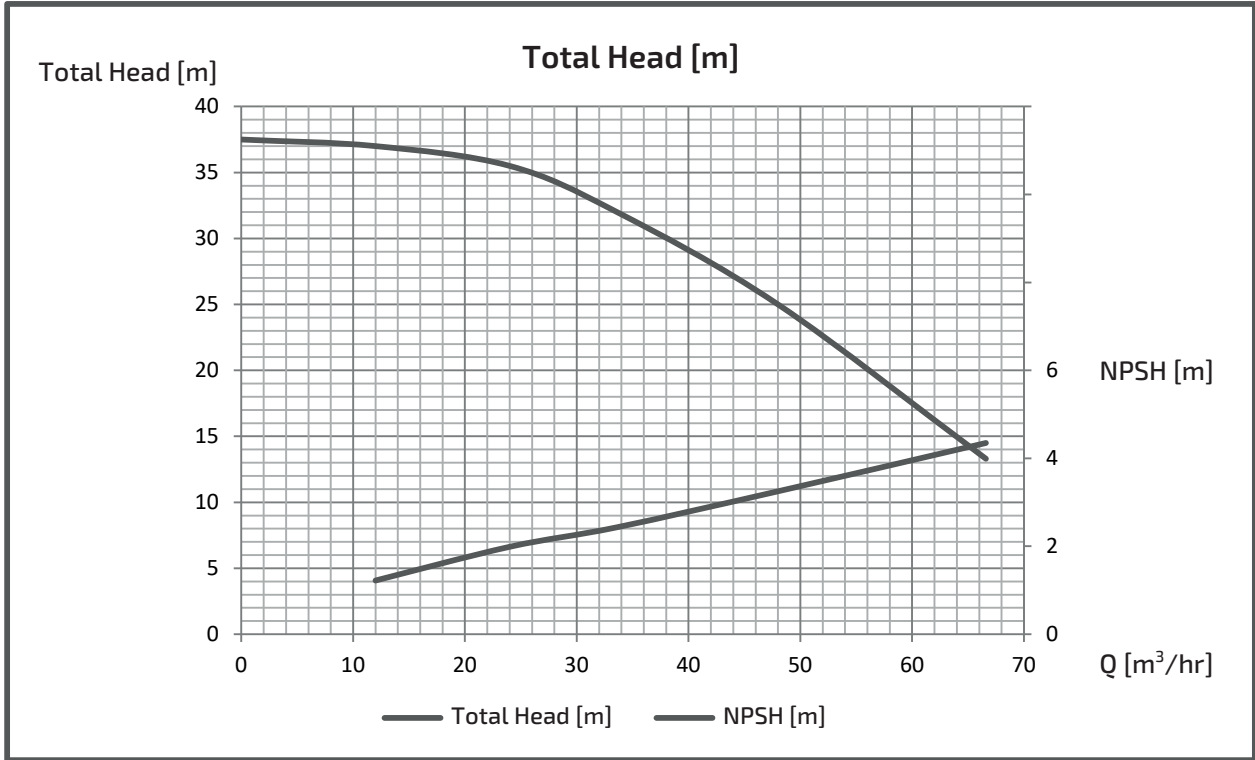

EXPECTED PERFORMANCE CURVE

MODEL : GS1005ME5.5

■ PERFORMANCE CURVES

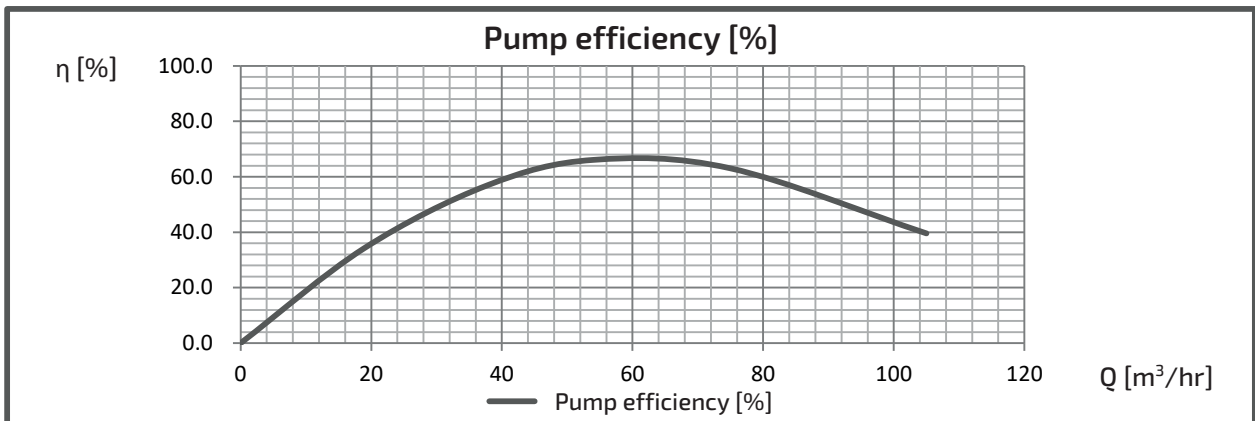
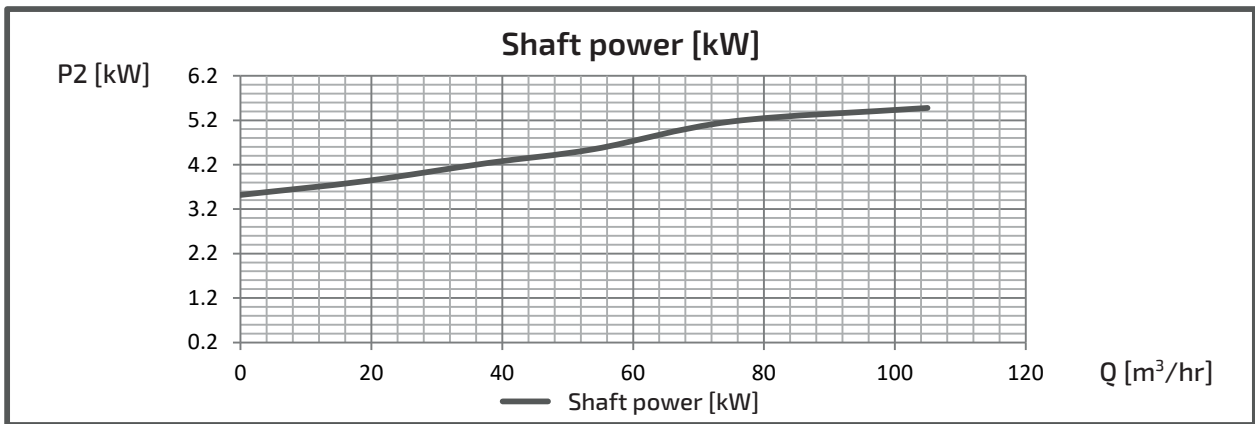
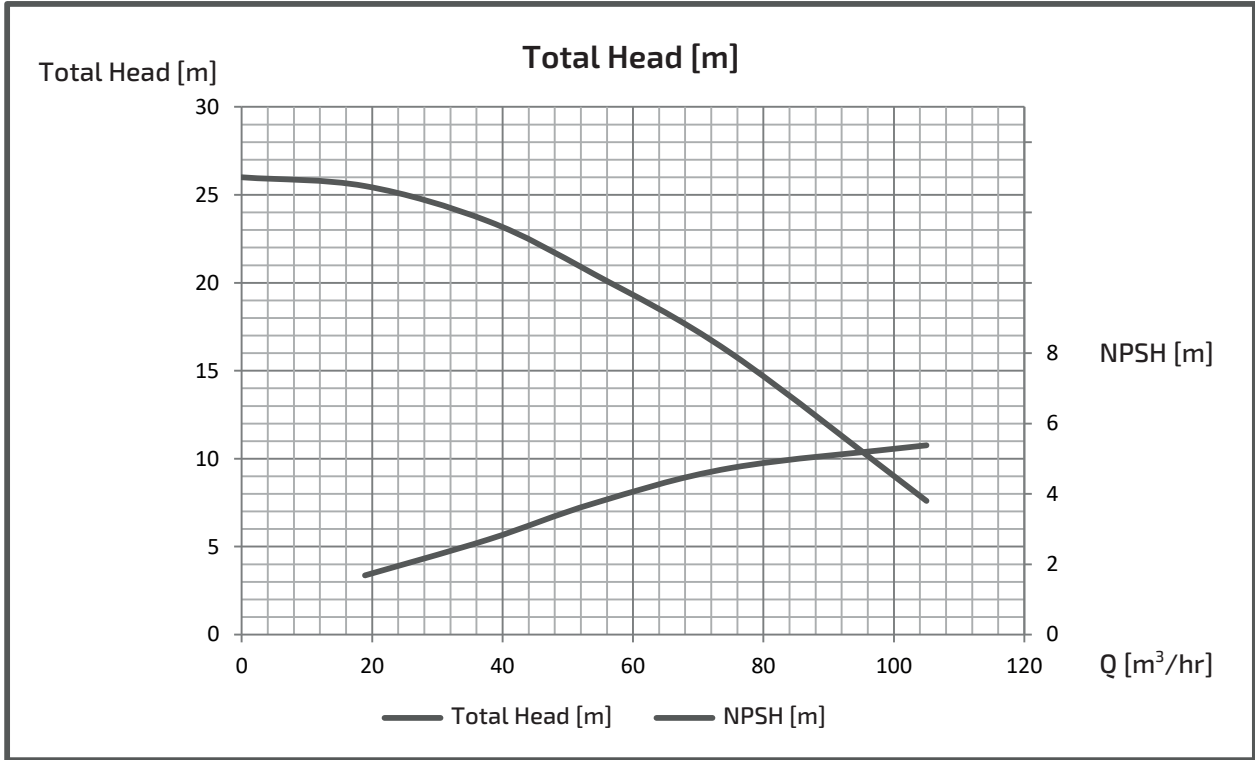

EXPECTED PERFORMANCE CURVE

MODEL : GS1005ME7.5

■ PERFORMANCE CURVES

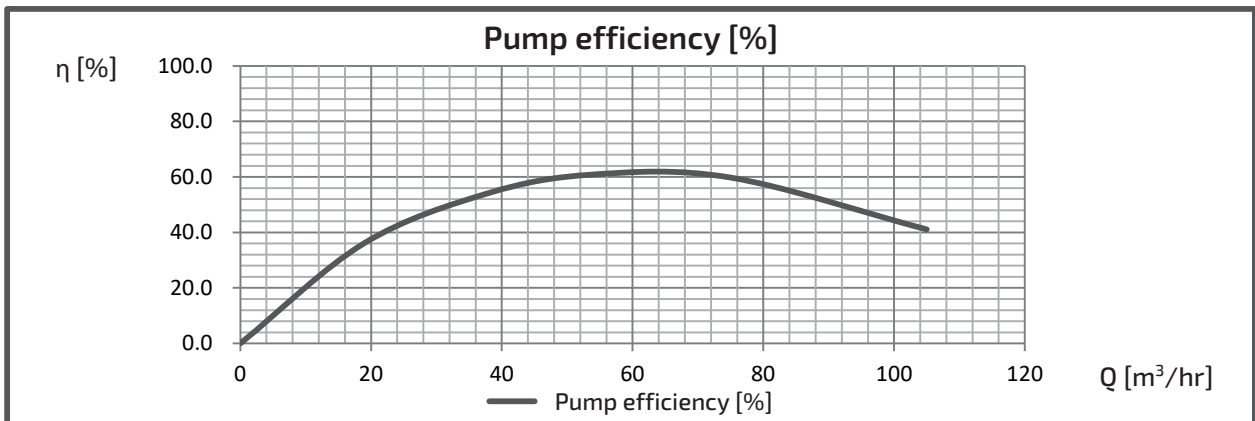
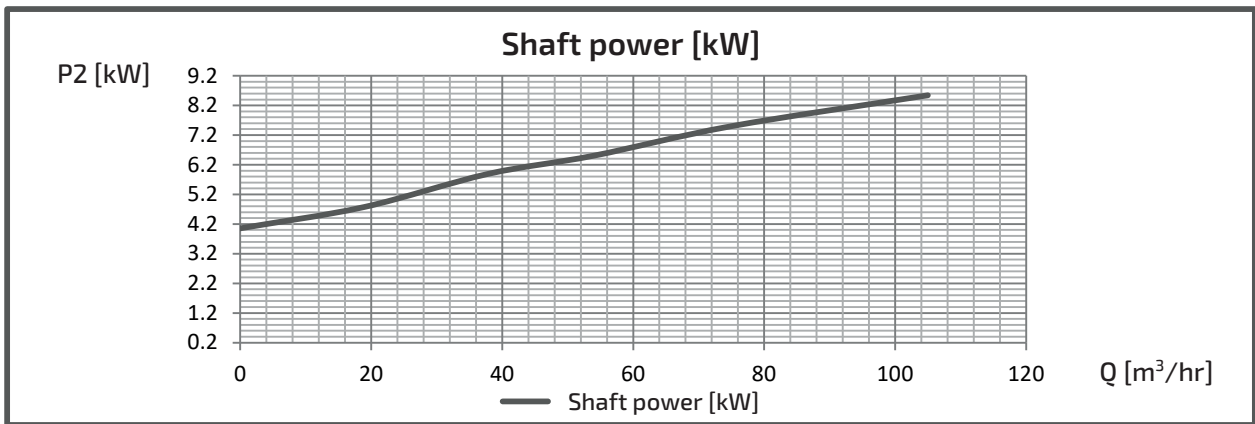
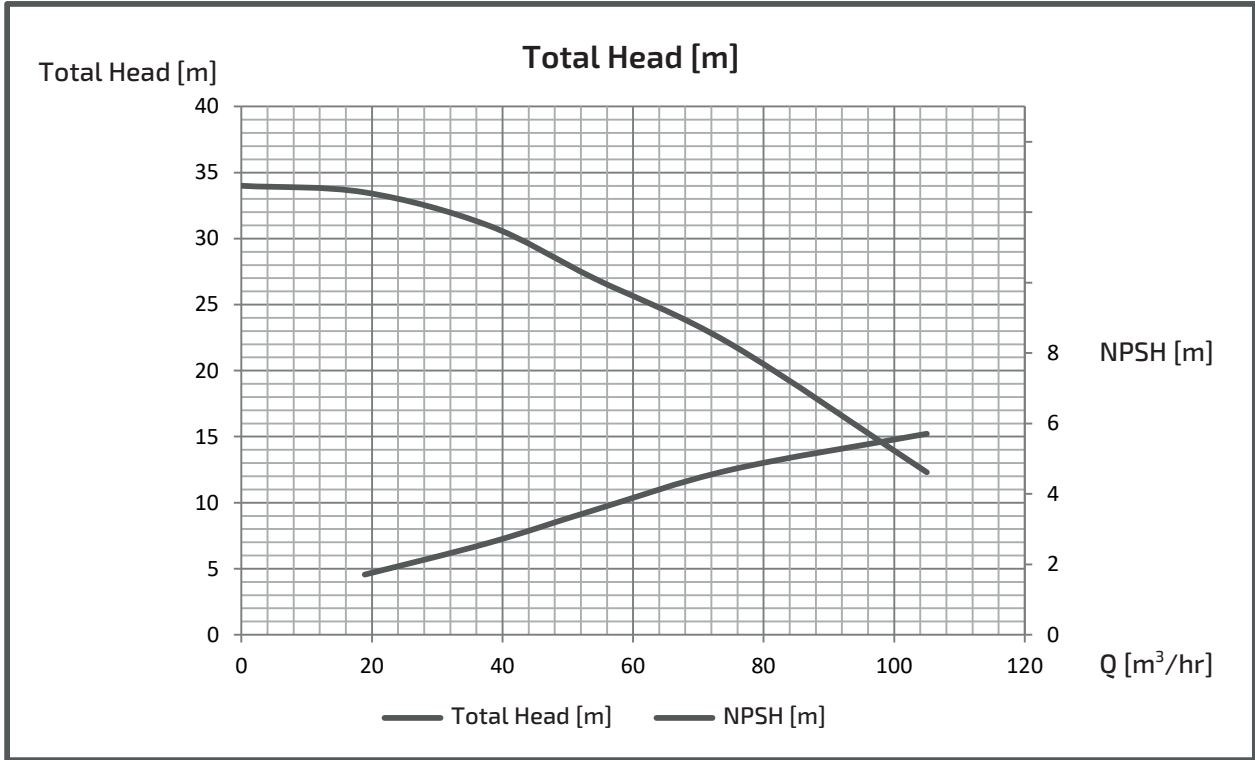

IMPORTANT SAFETY PRECAUTIONS

Always read the manual thoroughly and fully comprehend the contents for safe operation before starting use. Precautions for using products safely and for preventing personal injuries or physical damage are given in the manual.

- Matters falling under the following may not be covered by the warranty: uses out of the specified scope of application, failure to comply with precautions, improper repairs and alterations, matters arising from natural disasters, matters arising from the installation environment (improper power source, foreign objects, sand etc.), non-compliance with laws and regulations or standards pertaining thereto, accidental or intentional damage or injury, replacement of consumable parts, defects due to resale, etc.
- Do not use the product for applications out of the product specifications. Doing so may cause electric shock, fire, water leakage, etc.
- Have spare equipment ready when using pumps for equipment for living things (fish farms, fish tanks, aquariums, etc.) or critical equipment.
- Pump failure may cause lack of oxygen and water quality deterioration, and may affect the lives of the living things.
When using pumps for equipment for living things (fish farms, fish tanks, aquariums, etc.), do not install the pump in the tank where the living things are put into. The current leakage or sealing liquid leak from the mechanical seal may cause the death of the living things.
- If used to transport food-related items, give due consideration to the materials used. Contamination by foreign objects may occur.
- Avoid using for living things which disagrees with copper alloy. It may affect the lives of the living things.
- Select a product which is appropriate for your application. Inappropriate use of products may cause accidents.
- Conduct construction in accordance with the applicable laws and regulations (the Technical Standards of Electric Installation, interior wiring regulation, Building Standards Act, Water Supply Law, etc.). Not only does it violate the laws and regulations, but it also may cause injuries due to electric shock, fire, falling and tipping over.
- Do not use in places where people are assumed to get in contact with the product (baths, pools, lakes, etc.). Electric leak may occur and cause electric shock.
- Depending on the equipment, attach a filter etc. appropriate for your application on the discharge side before use, perform thorough flushing to check that there is no contamination. Cutting oil, rubber mold releasing agent, foreign objects etc. from the manufacturing line and cutting oil, foreign objects etc. from the pipeline may contaminate the liquid which is to be handled.
- Do not operate pumps with a specification of 50Hz at 60Hz. It may cause damage due to overpressure or burn damage of motors etc. due to overload. Do not operate pumps with a specification of 60Hz at 50Hz. Pump performance may be reduced.
- Only repair technicians may disassemble, repair, modify the product or replace cables. Defects may cause failure, damage, electrification or fire.
- It is recommended that both periodic and daily inspections be performed in order to ensure that the pump will operate reliably for as long as possible. Failure to perform inspections may lead to pump failure, accidents etc. For periodic inspections, please consult your distributor or our nearest sales office.

Note

Specifications/Configurations may be altered as a result of improvements and such.
Unauthorized reproduction of this document is prohibited.