



Comfort Earth®

Bringing valuable "water" to you



KAWAMOTO PUMP

Inverter automatic water supply unit

Pumper® **KFE-F**

KFE-A·P type

Super energy-saving.
(Raising overall efficiency)

Interactive control panel

Super beauty design

Equivalent to IE5/IE4

PAT.

New generation booster unit!!



New generation booster unit!!

Pumper® **KFE** series



Application

- Building water supply
- Small regional drinking water Industry
- Other general water supply

Smart Drive

Super Energy saving

Equivalent to

IE5

1 Overwhelming energy save performance

Accomplished great reduction of electrical power consumption compare with our previous model.

In the following general case, reduction amount corresponds to the annual power consumption of ordinary household, or equivalent to annual power generation from 24 psc of solar panel.

■ Comparison of annual consumed power

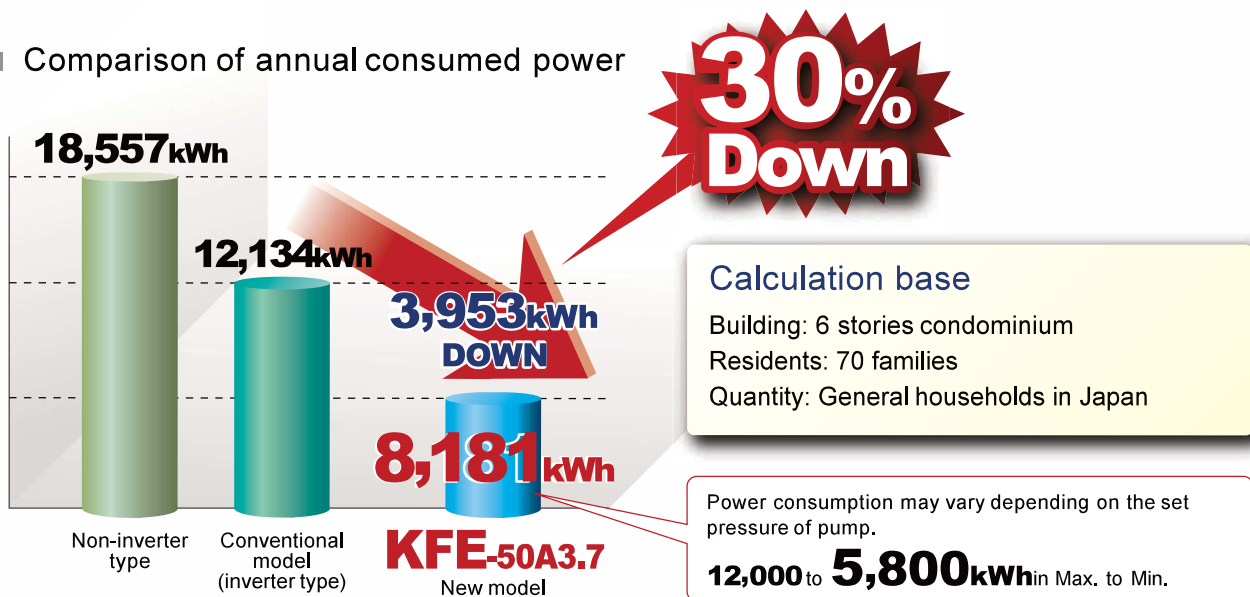

* e-star: Products with excellent energy-saving and environmentally friendly features. For further information, please refer to the end of this catalog.



優秀省エネルギー機器
Superior energy-saving
equipment

Agency for Natural Resources and Energy Minister's Award

Won



KFE-A P type

2 Adoption of PM motor equivalent to IE5*

A PM motor that boasts efficiency in the highest class,
and outstanding, world-class energy-saving performance.

■ What is PM motor? (permanent magnet synchronous motor)

It is a new AC motor, into the rotor of which is embedded not coil, but a permanent magnet. It is a new generation of motor, in which practical applications have progressed as a result of the dramatic improvements in the performance of permanent magnets that have been made in recent years. It features a small size, a light weight, high efficiency and high power. Especially, that's energy saving performance is admired.

※
IE5: This is highest motor efficiency class according to energy efficiency guideline UEC60034-30-2 which are discussing to establish now.

The motor of KEF-F 3.7kW or less is equivalent to IE5.
The motor of KFE-F not less than 5.5kW is equivalent to IE4 motor.

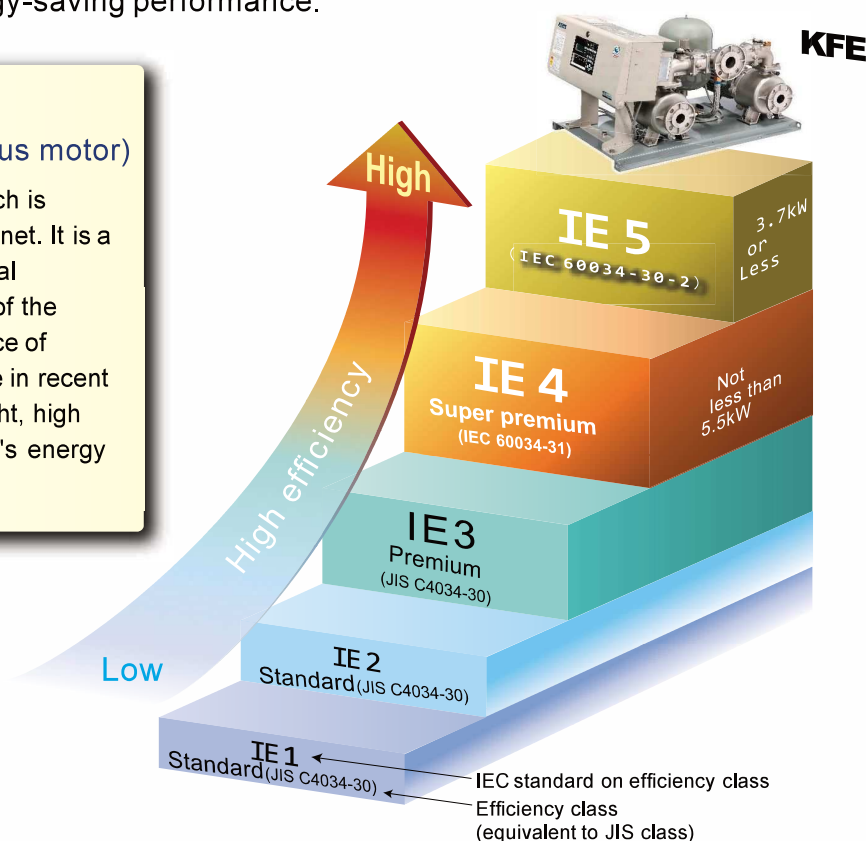

3 Extremely enhanced overall efficiency

Beginning with impellers, we have thoroughly reviewed the structure of the pump with fluid motion analysis raised the overall unit efficiency up. Improving overall efficiency is effective for making pumps energy-saving. KAWAMOTO PUMP aims to improve overall efficiency in both pump efficiency and motor efficiency.

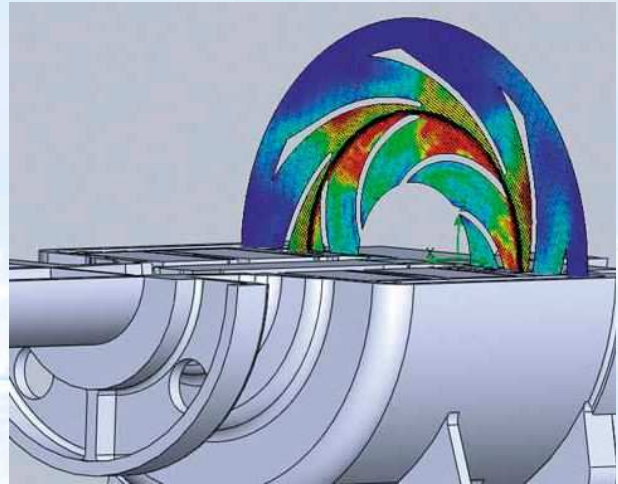

■ Highest overall efficiency within the specification
(compared with a 3.7-kW model of bore 40mm)

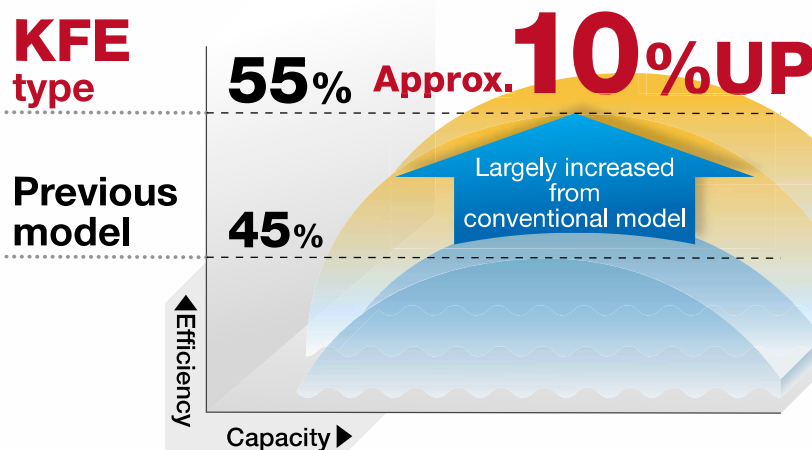

4 Interactive control panel & self diagnosis

Each setting, condition, and error history etc. can be checked on the LCD display through the interactive interface. Even in case of breakdown, diagnostic system can detect the probable cause, and will display it, so prompt recover is expected.



5 Super silent operation with duplex casing

This is the best choice for the building quietness is required. Duplex casing structure and fleshy casted casing suppress running water sound tightly. Electromagnetic noise from inverter is also controlled up to the limit.

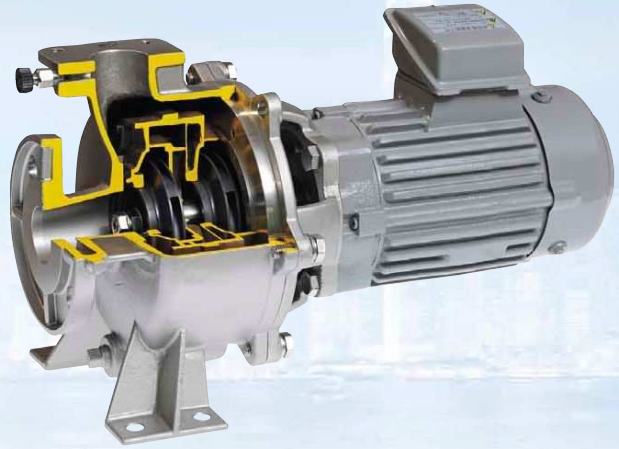

6 Easy maintenance structure

The user-friendly design makes it easy to see the structure inside the control panel, and this in turn means maintenance has been made easier. Furthermore, the inverters can be replaced easily from the back of the control panel.

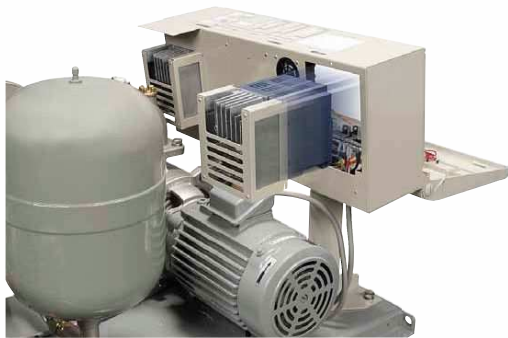

7 Surprisingly light, but powerful

We accomplished approximately 25% reduction in Weight even though a couple of meters rise in Total head compared to previous model. So, conveyance became easier.

New model

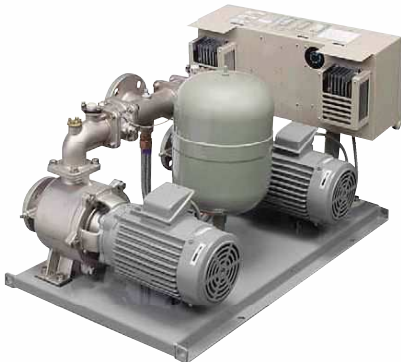

Previous model



**25%
Down**

High power factor and harmonic control

Using the high power factor devices with a DC reactor provided as a standard for each pump, and the generation of higher harmonics can be suppressed.* Complete measures against noise are also taken with the surge killer and noise filter for main circuit and control circuit.

*Complies with the "Higher harmonic suppression measure procedures for general-purpose inverter (input current 20A or less)" set by the Japan Electrical Machine Industry Association

Stainless steel precision casting

The pump casing and flanges are made from precision cast stainless steel to withstand heavy load and free from strain. Stainless steel and resin materials are mainly adopted for portion contacting water, thus preventing pump from rusting and red discolorment of water. Also conforms to leaching performance standards.

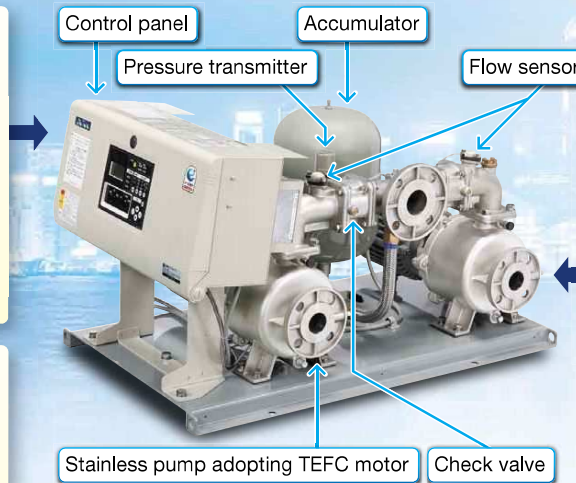

Silent and powerful water supply with **high pumping performance** and **efficiency impeller**.

- High efficiency DC brush less motor
- Temperature detective function
- Reliable backup function
- Heater terminal
- Use with either 50Hz or 60Hz.

Product Specifications

Water quality, water temperature		Fresh water, pH5.8 to 8.6, 0 to 40°C (however, there should be no freezing)	
Installation location (ambient temperature, humidity)		Indoors (0 to 40°C, 90% RH or lower, altitude: 1,000 m or lower)	
Power supply	Voltage(*)	Three-phase 200V	Acceptable range: 95 to 110% Interphase unbalance factor: 3% or less
	Frequency	Three-phase 380 to 440V	
Suction conditions	Inflow	Within 5 m	
	Suction	Total suction head: within -6 m (actual suction head: within -4 m)	
Pump		KR-C type stainless steel multi-stage turbine pump	
Control method		Estimated terminal constant pressure control using frequency control, or constant discharge pressure control	
Operation method		A: alternate operation, P: alternate parallel operation	
Control panel	Inverter	Low-noise PWM method	
	Motor protection device	Electronic thermal relay	
	Indicator lamps	Power supply, operation (individual), faults (individual), water full, water low, insufficient water	
	Measuring instruments	7-segment LCD display	Power supply voltage, discharge head, motor voltage (individual), motor current (individual), power consumption (individual), operating frequency (individual), fault history, water level history, cumulative operation time, cumulative number of starts, time, etc.
External signals (no-voltage)		Operation (individual), faults (individual), water full, water low, insufficient water	

(*): Read the nameplate carefully. Differs depending on the model.

(Note) If using flush valve, or using small amount of water continuously, consult KAWAMOTO beforehand.

Special specification

- Built-in Sluice valve type
- Stainless impeller (stainless cast steel(304)) type (bore 40, 50mm and 1.5 ~ 3.7kW models)
- With heater type (including thermostat)
- Control panel position change [back or side position (KFE-A, P3.7kW or less)]
- With BK type vibration proof bed type

Optional accessory

Pump cover

*Stainless steel materials models are also available



BK type vibration proof bed.

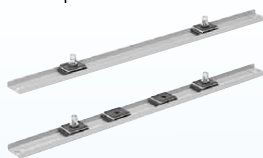

Heater for pump



Electrode holder



Foot valve



Discharge direction change connecting pipe



Running cost comparison (comparison within our company)

1 Running cost comparison

Calculation conditions

A: Trial calculation for alternate type.

For a set pump head, the trial calculation was conducted at the median within the range of the set pump head (Please use it as a reference, as the power consumption will vary depending on the set pump head.)

Example of bore 32mm

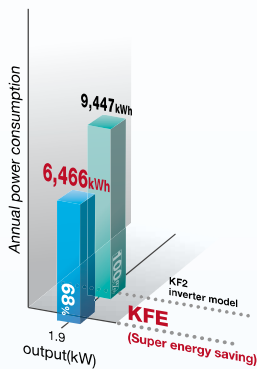

Example of bore 40mm

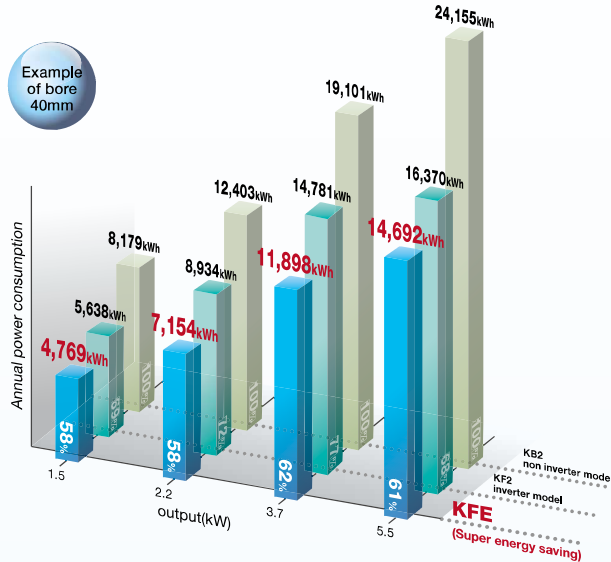

Example of bore 50mm

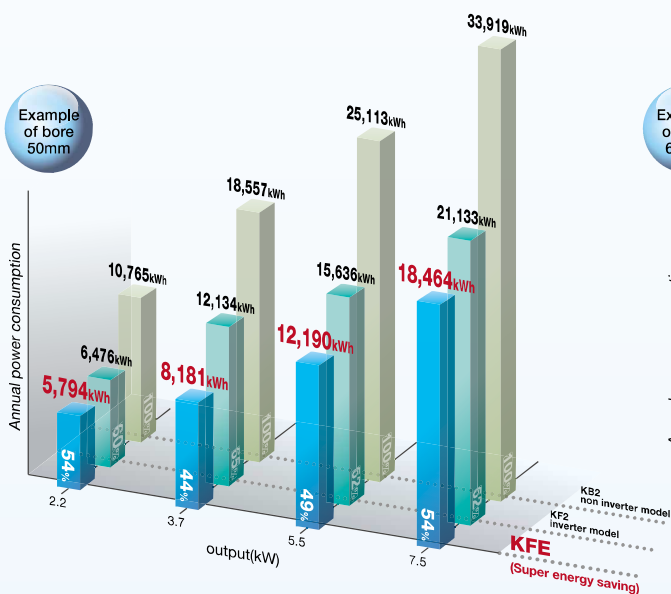

Example of bore 65mm

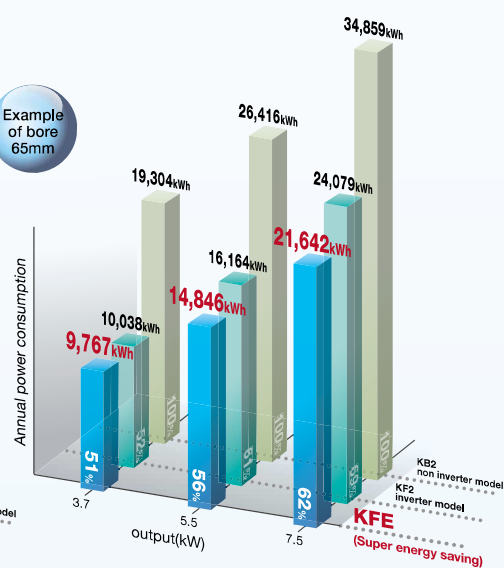

2 Comparison of power consumption at a low flow rate (Eco-driving function)

Forced driving time

KFE

10 to 60 seconds, auto optimization (Eco-driving function)

- If previous stop time < 50 seconds, Forced driving time = 60 seconds - Previous stop time
- If previous stop time ≥ 50 seconds, Forced driving time = 10 seconds

Conventional model (KF2 inverter type)

fixed in 60 sec

Bore 40, 1.5kW model

Example 1.

One cycle: Faucet open for 5 seconds, faucet closed for 65 seconds
Flow rate: 20 L/min

Model	Efficiency	Annual power consumption (kWh)
KFE	Eco-driving	83kWh (21.9%)
Conventional model (KF2 inverter type)	Standard	378kWh (100%)

Example 2.

One cycle: Faucet open for 20 seconds, faucet closed for 80 seconds
Flow rate: 20 L/min

Model	Efficiency	Annual power consumption (kWh)
KFE	Eco-driving	141kWh (45.2%)
Conventional model (KF2 inverter type)	Standard	312kWh (100%)

KFE-A Alternate operation

Selection chart

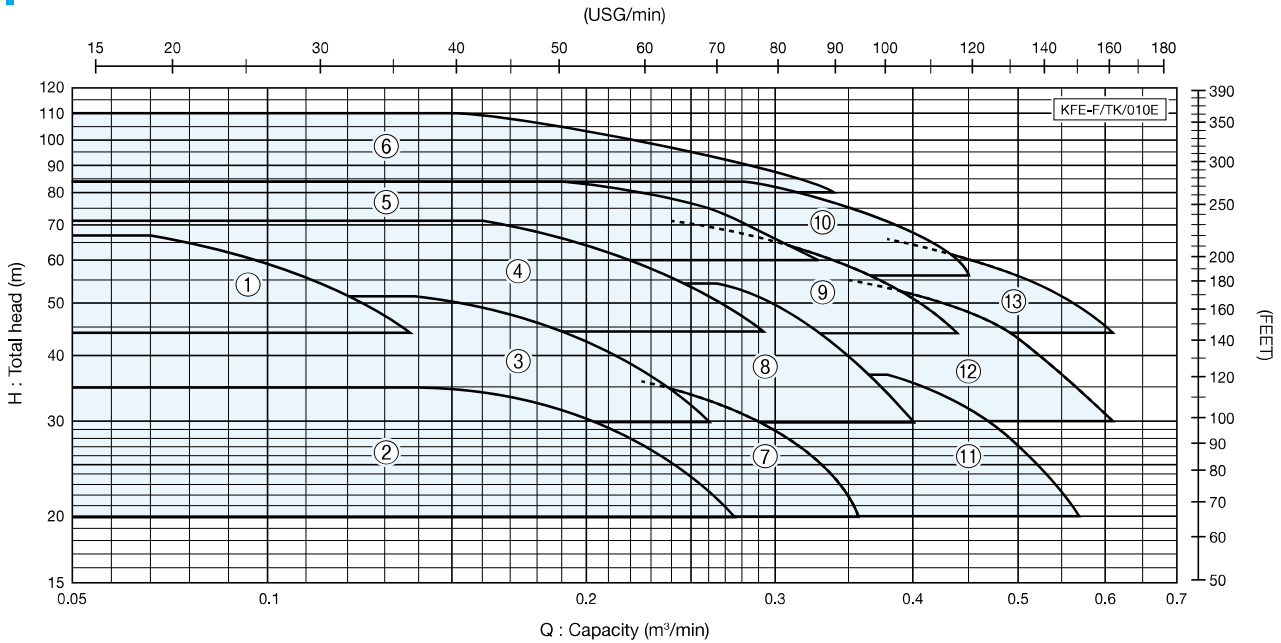

Specification table (Stop flow rate:10L/min)

KFE-F/SI/010E

Unit bore	Suction bore	Ref	Model	Motor *1	Standard specifications			Adjustable range of head	Accumulated pressure	Noise *2	Power factor
					Q	H	Starting head				
mm	mm			kW	m³/min	m	MPa	m	MPa	dB(A)	%
40	32	1	KFE32A1.9-F	1.9	0.07	67	0.55	44~67	0.32	53~54	85.5
		2	KFE40A1.5-F	1.5	0.14	35	0.26	20~35	0.14	52~53	89.6
	40	3	KFE40A2.2-F	2.2	0.14	51	0.41	30~51	0.22	53~54	89.2
		4	KFE40A3.7-F	3.7	0.16	71	0.59	44~71	0.32	55~57	88.7
		5	KFE40A5.5-F	5.5	0.19	84	0.71	60~84	0.45	59~61	87.9
		6	KFE40A7.5-F	7.5	0.15	110	0.93	80~110	0.61	61~63	90.4
	50	7	KFE50A2.2-F	2.2	0.225	36	0.27	20~36	0.14	53~54	89.2
		8	KFE50A3.7-F	3.7	0.265	54	0.44	30~54	0.22	54~56	88.7
		9	KFE50A5.5-F	5.5	0.24	71	0.59	44~71	0.32	59~61	87.9
		10	KFE50A7.5-F	7.5	0.28	84	0.71	56~84	0.42	59~63	90.4
50	65	11	KFE65A3.7-F	3.7	0.38	37	0.28	20~37	0.14	55~56	88.7
		12	KFE65A5.5-F	5.5	0.35	55	0.45	30~55	0.22	60~61	87.9
		13	KFE65A7.5-F	7.5	0.38	66	0.54	44~66	0.33	60~61	90.4

*1 Max. simultaneous operation units

*2 The noise level is the value given from 0 capacity to standard specification capacity. (reference)

(Note) When using large amount of flow rate such as a flushing valve, please consult KAWAMOTO PUMP.

Operation Theory Alternate operation

Processes from pump start to stoppage are performed alternately with two pumps.

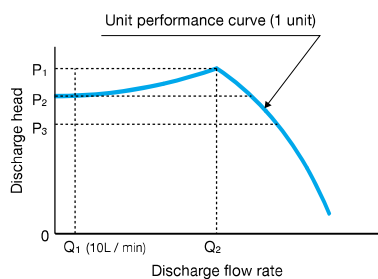

Q₁ = Stopped flow rate
Q₂ = Max. flow rate
P₁ = Operation head
P₂ = Estimated terminal head
P₃ = Starting head (P₂ - 4 m)

- 1 If water is used when the pump is stopped, and the head drops to P₃, the pressure sensor activates, and the pump starts.
- 2 When the amount of water used is between Q₁ and Q₂, water supply will continue at the constant estimated terminal pressure.
- 3 When the amount of water used drops to Q₁ or less, the flow rate sensor activates, and the pump stops.
- 4 Steps 1 to 3 are repeated alternately by pump No. 1 and No. 2.

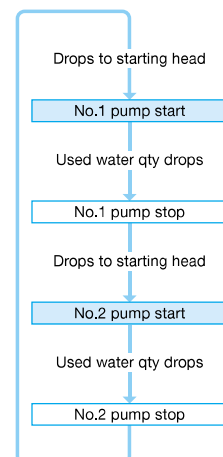

KFE-P Alternate / parallel operation

Selection chart

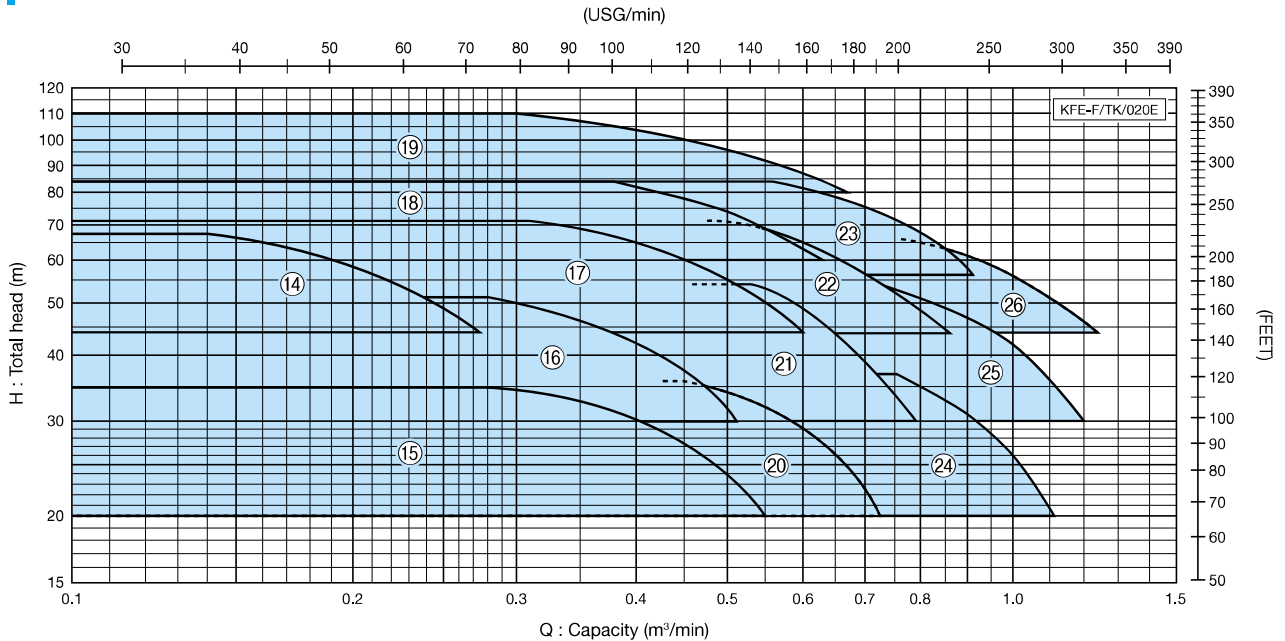

Specification table (Stop flow rate:10L/min)

Unit bore	Suction bore	Ref	Model	Motor *1	Standard specifications			Adjustable range of head	Accumulated pressure	Noise *2	Power factor
					Q	H	Starting head				
mm	mm			kW	m³/min	m	MPa	m	MPa	dB(A)	%
40	32	14	KFE32P1.9-F	1.9x2	0.14	67	0.55	44~67	0.32	53~58	89.9
50	40	15	KFE40P1.5-F	1.5x2	0.28	35	0.26	20~35	0.14	52~57	92.5
		16	KFE40P2.2-F	2.2x2	0.28	51	0.41	30~51	0.22	53~57	91.6
		17	KFE40P3.7-F	3.7x2	0.32	71	0.59	44~71	0.32	55~60	90.3
		18	KFE40P5.5-F	5.5x2	0.38	84	0.71	60~84	0.45	59~64	91.4
65	50	19	KFE40P7.5-F	7.5x2	0.30	110	0.93	80~110	0.61	61~66	92.7
		20	KFE50P2.2-F	2.2x2	0.45	36	0.27	20~36	0.14	53~57	91.6
		21	KFE50P3.7-F	3.7x2	0.53	54	0.44	30~54	0.22	54~58	90.3
		22	KFE50P5.5-F	5.5x2	0.48	71	0.59	44~71	0.32	59~64	91.4
80	65	23	KFE50P7.5-F	7.5x2	0.56	84	0.71	56~84	0.42	59~66	92.7
		24	KFE65P3.7-F	3.7x2	0.76	37	0.28	20~37	0.14	55~60	90.3
		25	KFE65P5.5-F	5.5x2	0.70	55	0.45	30~55	0.22	60~64	91.4
		26	KFE65P7.5-F	7.5x2	0.76	66	0.54	44~66	0.33	60~65	92.7

*1 Max. simultaneous operation units

*2 The noise level is the value given from 0 capacity to standard specification capacity. (reference)

(Note) When using large amount of flow rate such as a flushing valve, please consult KAWAMOTO PUMP.

Operation Theory Alternate / parallel operation

The operation method is changed automatically based on the amount of water used.

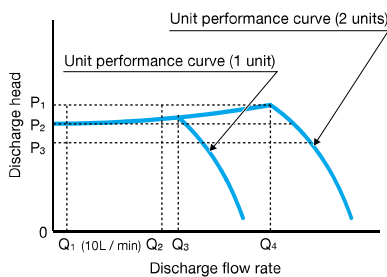

Q₁ = Stopped flow rate P₁ = Operation head
 Q₂ = Parallel off flow rate P₂ = Estimated terminal head
 Q₃ = Parallel flow rate P₃ = Starting head (P₂-4 m)
 Q₄ = Max. flow rate

- 1 If water is used when the pump is stopped, and the head drops to P₃, the pressure sensor activates, and the pump starts.
- 2 When the amount of water used is between Q₁ and Q₂, water supply will continue at the P₁ constant estimated terminal pressure.
- 3 When the amount of water used drops to Q₁ or less, the flow rate sensor activates, and the pump stops.
- 4 If the amount of water used is less than Q₃, alternate operation is performed repeatedly.
- 5 If the amount of water used increases to Q₃ or more during one-pump operation, and the pressure drops to P₂, the second pump starts and parallel operation is performed.
- 6 If the amount of water used is Q₂ or less during parallel operation, the pump started first stops (parallel off), and one-pump operation is performed.
- 7 If the amount of water used is less than Q₃, alternate operation is performed, and if Q₃ or more, steps 5 and 6 are repeated.

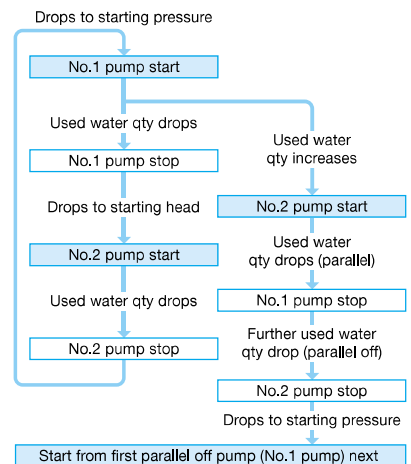

KFE-A·P

Control panel ECSG4-A·P



(Picture shows the model of 3.7 kW or less)

Display

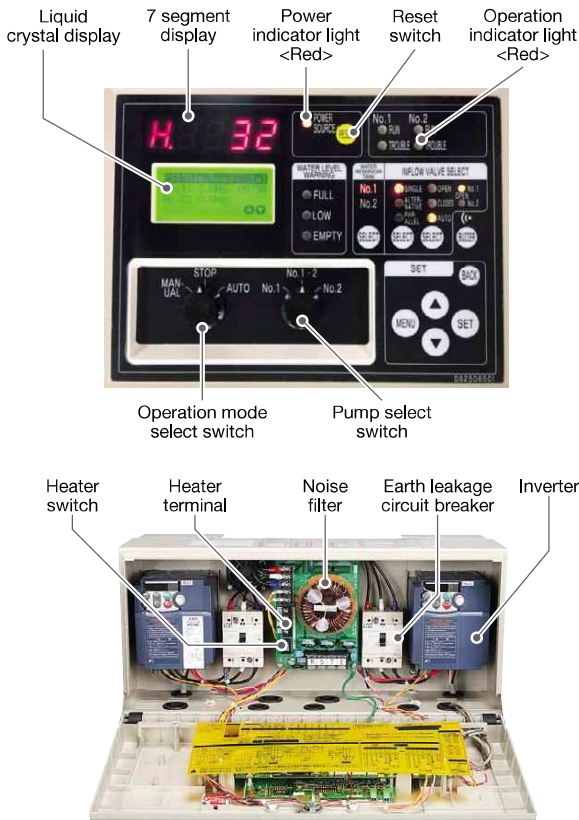

- Inverter, DC reactor and Earth leakage circuit breaker for each pump
- Noise filter
- Circuit for inflow motorized valve for twin reservoir
- Compatible twin reservoir system (5 poles)

Model	ECSG4-A·P	
Output	1.5~7.5kW	
Operation method	Alternate or Alternate/Parallel	
Rated voltage	Three phase 200V, 380~440V	
Installation	Indoor, Altitude: 1,000m or less, Ambient temperature 0~40°C, Humidity 90RH% or less	
Components	Earth leakage circuit breaker (with AL contactor)	For each pump
	DC reactor	For each pump
	Noise filter	Serve both main and control circuits.
	Inverter	For each pump
	Control board	With water level relay
Operation indicator	Power supply	Indicator light
	Operation	Indicator light (for each pump)
	Discharge head	Digital
	Power source, Current, Frequency	Digital
Trouble indicator	Cumulative operation time, Cumulative start count	Digital
	Trouble	Indicator light (for each pump)
	Discharge pressure drop	Indicator light (Trouble message)
	Earth leakage	Indicator light (Trouble message)
	Discharge pressure transmitter trouble	Indicator light (Trouble message)
Function	Full level, Low level, Empty	Indicator light (Trouble message)
	Water level control	<input type="radio"/> For twin reservoir system. (5 poles)
	Inflow motorized (solenoid) valve control	<input type="radio"/> For twin reservoir system. (3 poles)
	Pump trouble	<input type="radio"/> (Automatic substitute operation)
	Inverter trouble	<input type="radio"/> (Automatic substitute operation)
External no voltage signal	Retry for malfunction prevention.	<input type="radio"/>
	Buzzer	<input type="radio"/> (with ON-OFF switch)
	Operation	<input type="radio"/> (Individual)
	Trouble	<input type="radio"/> (Individual)
	Water-full	<input type="radio"/>
Water-low	<input type="radio"/>	
Water-empty	<input type="radio"/>	

Trouble Warning List

Unit protection

7-segment display	Details
StOP	Power failure
PEd	Discharge pressure transmitter error
FOP	External interrupt
CPE	Control PCB error
*-HdL	Discharge pressure drop
*-ELb	Electrical leakage

* "1" is displayed for the No.1 pump, and "2" for the No.2 pump.

Water level error

7-segment display	Details
*-HL	Water full
*-LL2	Water low
*-LL1	Water insufficient

* "1" is displayed for the No.1 receiving water tank, and "2" for the No.2 receiving water tank.

Inverter protection

7-segment display	Details
*-Er8	Inverter communication error Control panel earth leakage circuit breaker "OFF"
*-OC1	Overcurrent (during acceleration)
*-OC2	Overcurrent (during deceleration)
*-OC3	Overcurrent (when running at constant speed)
*-OU1	Overvoltage (during acceleration)
*-OU2	Overvoltage (during deceleration)
*-OU3	Overvoltage (when running at constant speed)
*-LU	Insufficient voltage
*-OPL	Output phase-loss
*-OH1	Inverter abnormal temperature rise
*-OLU	Overload
*-OL1	Electronic thermal relay
*-Er1	Memory error
*-Er3	CPU error
*-Erd	Step-out detection
*-ErF	Data save error when voltage insufficient

* "1" is displayed for the No.1 pump, and "2" for the No.2 pump.

* If a fault warning other than described here is displayed, consult your dealer or KAWAMOTO.

Example of a connection to the control panel

Three phase 400V Alternate/Parallel operation

Control panel: ECSG4 type, 400 V model

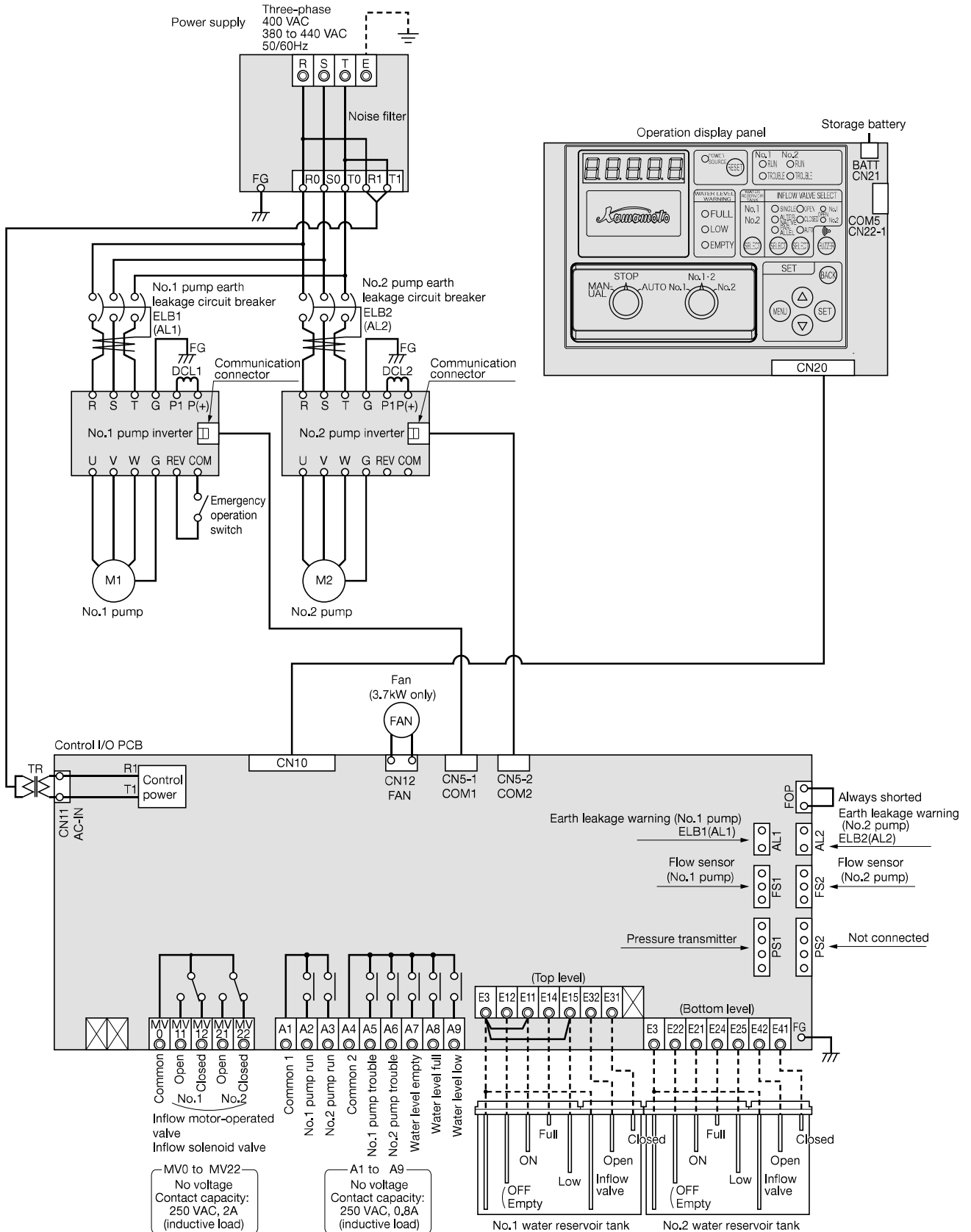

· If exceeding the above contact capacities, use a relay.

· Disconnect short circuit wire between "E3" and "E11", or between "E3" and "E15" if performing water level control.

Outline dimension table

Please request a delivery specification when planning for an installation.

Standard specification of 3.7kW or less

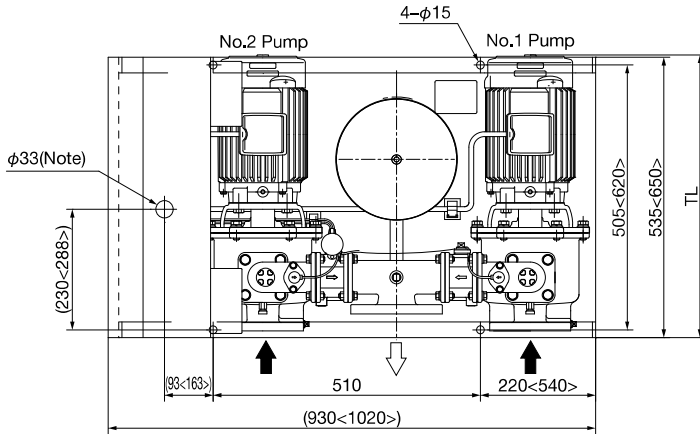

*Foundation bolts are optional accessories. Please purchase separately.
(Recommend foundation bolt size: M12X160)
Note : Showing the position on bottom surface of control panel, there is no hole on the base.
Value enclosed in < > shows the dimension for 65mm bore models

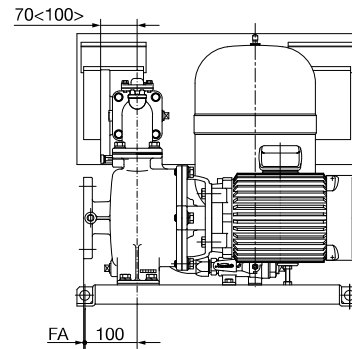
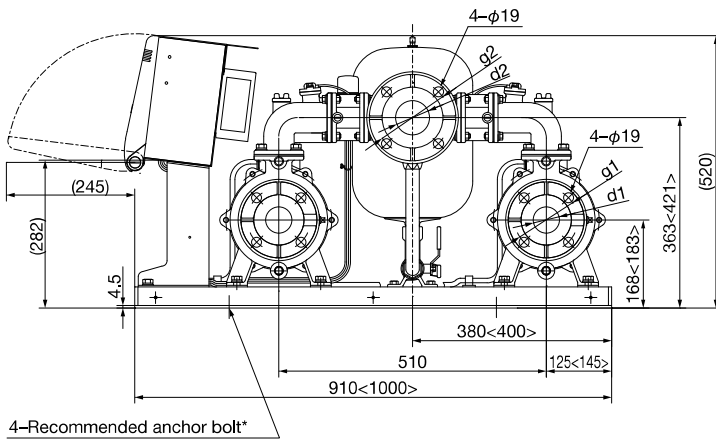

KFE-F/D/010E

Unit : mm

d2	d1	Model	Motor	Combinations		Flange				Mass
			kW	FA	TL	d1	d2	g1	g2	kg
40	32	KFE32A(P)1.9-F	1.9	2	-	32	40	100	105	116
40(50)	40	KFE40A(P)1.5-F	1.5	-40	-	40	40(50)	105	105(120)	108(109)
		KFE40A(P)2.2-F	2.2	2	-	40	40(50)	105	105(120)	117(117)
		KFE40A(P)3.7-F	3.7	2	540	40	40(50)	105	105(120)	124(124)
40(65)	50	KFE50A(P)2.2-F	2.2	-40	-	50	40(65)	120	105(140)	117(117)
		KFE50A(P)3.7-F	3.7	2	540	50	40(65)	120	105(140)	125(126)
50(80)	65	KFE65A(P)3.7-F	3.7	20	650	65	50(80)	140	120(150)	169(170)

Note1) < - > (minus) in the table shows reverse direction to the drawing. TL is omitted in case TL < 535

Note2) 3 kg is added in the table mass in case built-in sluice valve model.

Note3) 2 kg is added in the table mass in case stainless impeller model.

Note4) (P) in above table shows the model name in alternate & parallel operation model.

The value enclosed in () in above table shows the dimensions for alternate & parallel operation model.

KFE-F/d/010E

Standard specification of 5.5kW or more

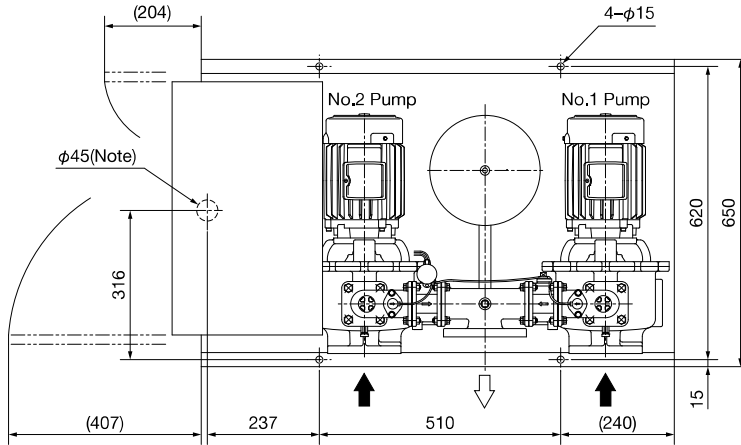

*Foundation bolts are optional accessories. Please purchase separately.

(Recommend foundation bolt size: M12X160)

Note : Showing the position on bottom surface of control panel, there is no hole on the base.

Value enclosed in < > shows the dimension for 65mm bore models

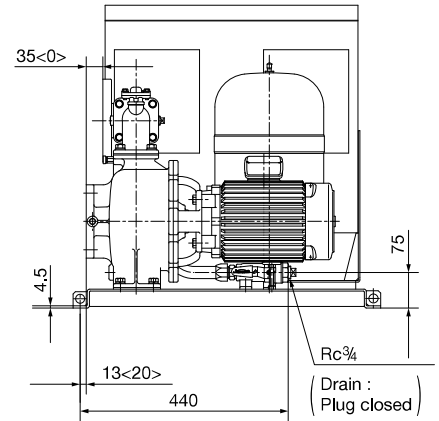
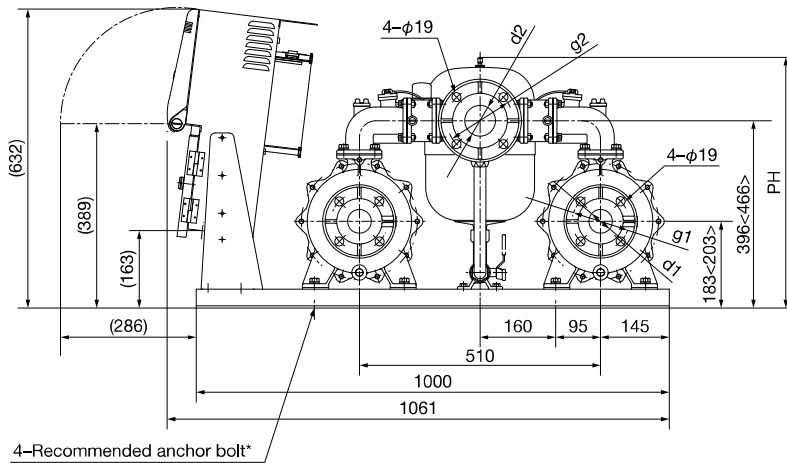

KFE-F/D/020E

Unit : mm

d2	d1	Model	Motor	Combinations	Flange				Mass
			kW	PH	d1	d2	g1	g2	kg
40(50)	40	KFE40A(P)5.5-F	5.5	-	40	40(50)	105	105(120)	164(165)
		KFE40A(P)7.5-F	7.5	662	40	40(50)	105	105(120)	173(174)
40(65)	50	KFE50A(P)5.5-F	5.5	-	50	40(65)	120	105(140)	164(165)
		KFE50A(P)7.5-F	7.5	-	50	40(65)	120	105(140)	169(170)
50(80)	65	KFE65A(P)5.5-F	5.5	-	65	50(80)	140	120(150)	184(185)
		KFE65A(P)7.5-F	7.5	-	65	50(80)	140	120(150)	189(190)

Note1) PH is omitted in case PH < 632.

Note2) 3 kg is added in the table mass in case built-in sluice valve model.

Note3) (P) in above table shows the model name in alternate & parallel operation model.

The value enclosed in () in above table shows the dimensions for alternate & parallel operation model.

KFE-F/d/020E

Exploded drawing & Parts list (Package)

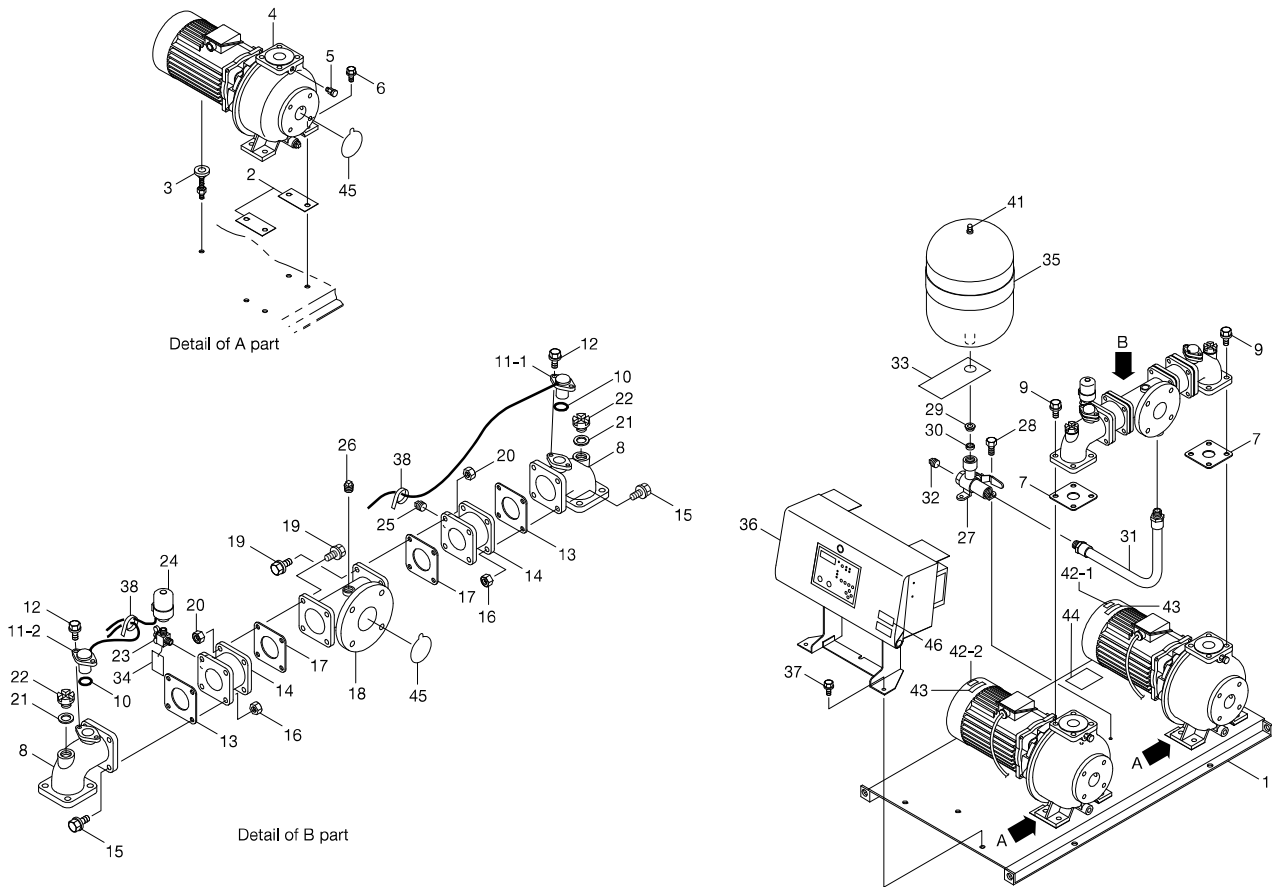

Ref. No.	Parts name	Material	Q'ty
1	Base	(Steel plate)	1
2	cushion	Rubber	4
3	cushion	Rubber, steel	2
4	Pump		2
5	Exhaust valve	(SUS304)	2
6	Bolt with built in washer	SUSXM7	8
7	Square flange packing	EPDM	2
8	Connecting bend pipe	Stainless cast steel (304)	2
9	Bolt with built in washer	SUSXM7	8
10	O-ring	NBR-70-1	2
11-1	Flow sensor		1
11-2	Flow sensor		1
12	Bolt with built in washer	(SUSXM7)	4
13	Square flange packing	EPDM	2
14	Check valve	Stainless cast steel (304)	2
15	Bolt with built in washer	SUSXM-7	8
16	Nut	SUS304	8
17	Square flange packing	EPDM	2
18	Connecting pipe	Stainless cast steel (304)	1
19	Bolt with built in washer	SUSXM-7	8
20	Nut	SUS304	8
21	Ring packing	EPDM	2
22	Plug	NCRB-1	2

Ref. No.	Parts name	Material	Q'ty
23	Ball valve	(C3771BD)	1
24	Pressure transmitter		1
25	Plug	Stainless cast steel (304)	1
26	Plug	Stainless cast steel (304)	1
27	Ball valve	Stainless cast steel (304)	1
28	Bolt	SUS304	2
29	Ring	SUS304	1
30	Ring packing	EPDM(A707)	1
31	Flexible joint	SUS304	1
32	Plug	Stainless cast steel (304)	1
33	Tag	(Paper)	1
34	Tag	(Paper)	1
35	Accumulator		1
36	Control panel		1
37	Bolt with built in washer	SUSXM7	3
38	Band	PA	2
41	Indication label	PVC	1
42-1	Indication label	Paper	1
42-2	Indication label	Paper	1
43	Nameplate	Polyester film	2
44	Nameplate	A1100P-H24	1
45	Cover	Polyester	3
46	Nameplate	Polyester film	1

Exploded drawing & Parts list (Pump)

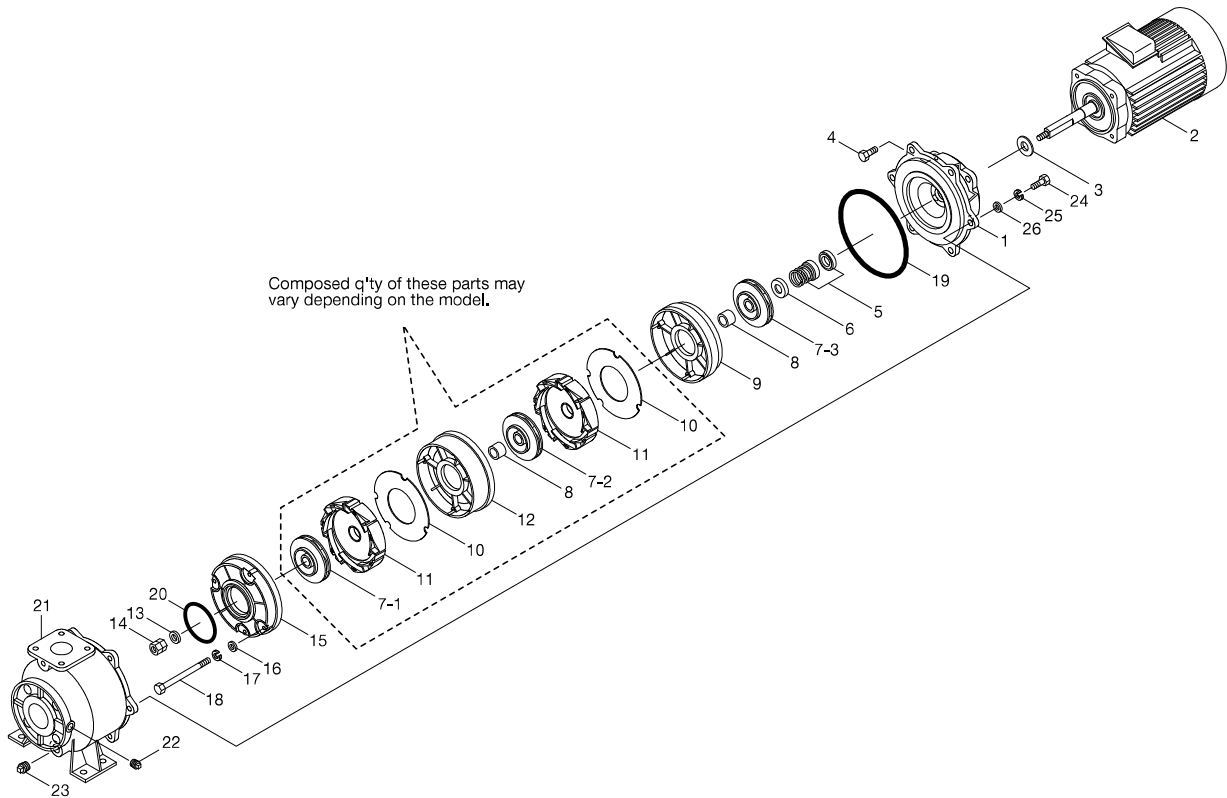

Ref. No.	Parts name	Material	Q'ty
1	Casing cover	Stainless cast steel (304)	1
2	KPM motor		1
3	Deflector	Rubber	1
4	Bolt	SUS304	4
5	Mechanical seal		1
6	Spring shoe	SUS304	1
7-1	Impeller	(PPS-GF30)	1
7-2	Impeller	(PPS-GF30)	1
7-3	Impeller	(PPS-GF30)	1
8	Sleeve	SUS304	1
9	Guide vane	(PPS-GF40)	1
10	Parting plate	SUS304	1
11	Guide vane	(PPS-GF40)	1
12	Guide vane	(PPS-GF40)	1

Ref. No.	Parts name	Material	Q'ty
13	Plane washer	SUS304	1
14	Nut	SUS304	1
15	Guide vane	(PPS-GF40)	1
16	Plane washer	SUS304	4
17	Spring washer	SUS304	4
18	Bolt	SUS304	4
19	O-ring	NBR-70-1	1
20	O-ring	NBR-70-1	1
21	Casing	Stainless cast steel (304)	1
22	Plug	Stainless cast steel (304)	1
23	Plug	Stainless cast steel (304)	1
24	Bolt	SUS304	6
25	Spring washer	SUS304	6
26	Plane washer	SUS304	6

This drawing and list are typical example of KFE series.
Structures and materials may differ slightly according to actual model.



Comfort Earth®

To reduce the environmental burden and protect the environment, we at KAWAMOTO PUMP will keep on carrying out activities as a united force under our slogan "Comfort Earth", as a company involved with the valuable resource that is "water".



Kawamoto products with this mark are products with excellent energy-saving and environmentally friendly features.



Important safety precautions

Always read this manual thoroughly and fully comprehend the contents before starting use. Precautions for using this product safely and for preventing personal injuries or physical damage are given in this manual. * We bear no responsibility when the above listed precautions are not observed.

- Select a product which is appropriate for your application. Inappropriate use of products may cause accidents.
- Do not use the product for applications out of the product specifications. Doing so may cause electric shock, fire, water leakage, etc.
- When using this pump for living things (fishery, fish tank, aquarium, etc.) or important equipment, always prepare a spare unit. If the pump fails, an oxygen deficiency or degradation of water quality, etc., could occur and affect the creature's life.
- If used to transport food-related items, give due consideration to the materials used. Contamination by foreign objects may occur.
- Avoid using this product with living things that are susceptible to copper alloys. The life of the creature could be affected.
- Do not directly connect pump with water main. It may be prohibited under the Water Supply Law. Also, water backflow may contaminate tap water.
- Carry out installation in accordance with applicable legal requirements (electrical equipment guideline, interior wiring regulations, building codes, etc.) Failure to observe this may not only violate legal requirements, but could also result in fire or electric shock, or injury caused by falls or topples.
- Observe the service life of the pump, install it in a well ventilated place free from corrosive or explosive gases, salt, moisture, water vapor, condensation etc., and avoid exposing it to wind, rain and direct sunlight. In a harsh environment, electric leakage, electric shock or fire may result from deterioration of insulation in the motor or control panel, etc.
- Do not install the pump in a location that has not been treated for drainage, or that has not been waterproofed. Water leakages could result in significant damage. * We bear no responsibility for any damage arising from lack of drainage or waterproofing.
- Depending on the equipment, install the appropriate filter or etc in accordance with the application, properly flush the system and make sure that it is free of foreign matter before starting operation. Cutting oil, rubber mold releasing agent, foreign objects etc, from the manufacturing line and cutting oil, foreign objects etc, from the pipeline may contaminate the liquid which is to be handled.
- Install buzzers, etc., as an alarm to alert failure to be noticed. Failing to do so may result in serious accidents without noticing a failure.
- If using devices such as flush valve associated with sudden changes in flow rate, consult your dealer or KAWAMOTO beforehand. Using a flush valve while the pump is stopped will cause the pressure inside the pipes to drop suddenly, and this could result in pressure fluctuations or mixing with air.
- Do not equip the pump with a phase advancing capacitor. Failure to observe this could lead to trouble such as abnormal heat generation.
- When using a generator with models equipped with an inverter, contact your dealer or KAWAMOTO. Failure to observe this could result in control panel (electric parts assembly box) or generator faults or damage.
- Do not put the flammable items on the pump surroundings or inside the pump cover or control panel, or cover the pump, cable or control panel with the flammable items. Failure to observe this could overheat and result in burning.
- Only repair technicians may disassemble, repair, modify the products or replace cables. Improper repairs could result in electric shocks, fires, faults or break.
- It is recommended that both periodical and daily inspections be performed in order to ensure that the pump will operate reliably for as long as possible. Failure to perform inspections may lead to pump failure, accidents etc. For periodic inspections, please consult your distributor or our nearest sales offices.

Specifications/configurations may be altered as a result of improvements and such. Unauthorized reproduction of this document is prohibited.

Distributor

Kawamoto Pump MFG. CO., LTD.

Overseas Marketing Section
11-39, Osu 4-Chome, Naka-ku, Nagoya
460-8650, JAPAN

TEL: +81-52-251-7173 FAX: +81-52-747-5500
E-mail: kawamotobo@kawamoto-oms.com
<http://www.kawamoto.co.jp>

For any question about pumps, please contact your nearest distributor

Name	KFE-A•P
No.	3599TE