

Uniting water with an abundant lifestyle ●●●●● Kawamoto Pump

Compact Self-Priming Volute Pump

GSO2/3- C Type Instruction Manual

Thank you for purchasing the GSO2-C Type Compact Self-Priming Volute Pump. This instruction manual provides information for the construction company to safely use this pump unit, and for handlers to carry out maintenance and inspection, etc. Always read this manual thoroughly and fully comprehend the contents before starting work. Please keep this instruction manual in a handy place for quick reference.

<Contents>

[1] Introduction	2	[6] Electrical Work.....	6
[2] Specifications	2	[7] Operation.....	7
[3] Product Configuration.....	3	[8] Maintenance and Inspection	8
[4] Installation	4	[9] Disassembly and Assembly	9
[5] Piping	5	[10] Troubleshooting	10

Special Notes

1. Always earth the equipment with Class D (Class 3) earthing, and install a dedicated earth leakage breaker. Failure to observe this could result in earth leakages, faults, electric shocks or fires.
2. The electrical work must be completed according to the "Electrical Installation Technical Standards", "Wiring Regulations" and any other applicable regulations. Improper wiring and connections could lead to earth leakage or fire.
3. Do not run the pump in a dry mode (without water in the pump) or in a shutoff mode (without water inflow to, or discharge from, the pump). Such operations could cause the pump to become extremely hot, possibly resulting in burn injuries.
4. Do not install the pump that is not waterproof or that has not drainage facility. Major disasters could occur if water leaks.

Precautions for using this product safely and for preventing personal injuries or physical damage are given in this manual.

The precautions are classified as "Warning" and "Caution" to alert of the degree of injury or damage that could occur if handling is mistaken.

In either case, these are important matters related to safety, and must be observed.

 **Warning** : Details which if ignored could lead to fatalities or serious injuries.

 **Caution** : Details which if ignored could lead to personal injuries or physical damage.

(Note) The conventional unit and values based on these given in parentheses are provided as reference.

[1] Introduction

Please check the following items upon receipt of the product.

- (1) Check the nameplate to ensure that the correct pump has been delivered. (Model etc.)
- (2) Check that no parts have been damaged during transportation, and that none of the bolts, nuts, etc., are loose. Tighten any part that is loose.
- (3) Check that all accessories are in order.

<<If there is any problems, contact your dealer>>

[2] Specifications

Caution

- Always use this pump within the specified product specifications.
Failure to do so could result in electric shock, fire, residual currents, etc.

2.1 Specifications

Pumped, fluid	Fluid quality	Fresh water (PH 6.5 to 8)
	Fluid temp.	0 to 40°C
Installation location		Indoor
Ambient temperature/humidity		0 to 40°C/85% RH or less
Total suction head		Within -8m (20°C)
Motor	Type	Totally-enclosed fan-cooled indoor type, 2-pole
	Phase	3-phase
	Voltage	50Hz : 380V

[3] Product Configuration

3.1 Structure

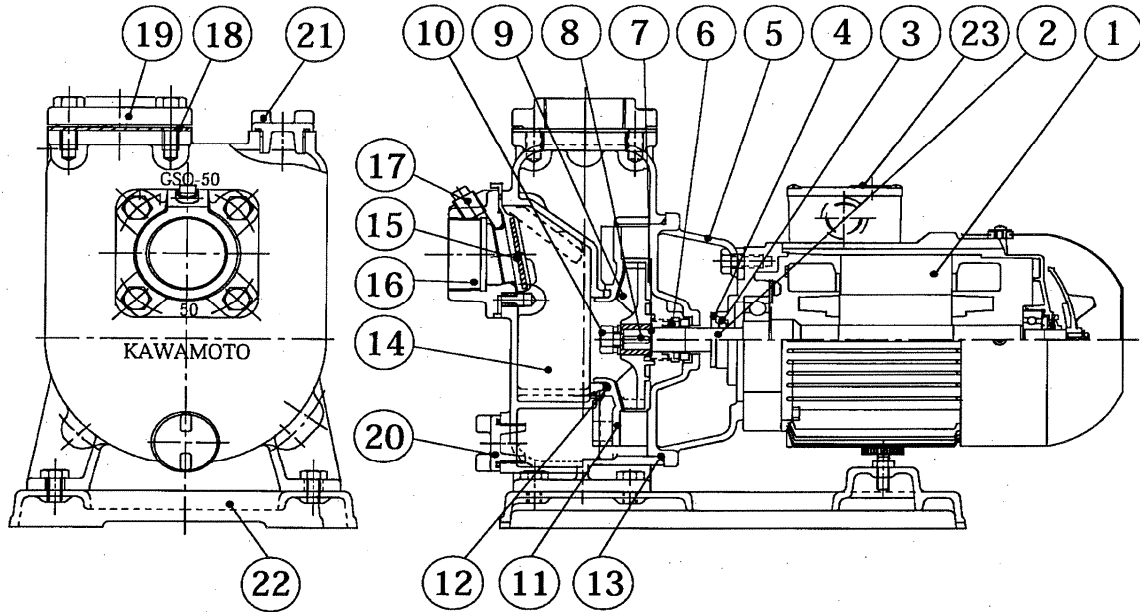

No.	Name	Material	Remarks	No.	Name	Material	Remarks
1	Motor	-	Totally-enclosed	13	O-ring	Rubber (NBR)	
2	Main shaft	SUS304+S35C	JISG4303 JISG4051	14	Casing	FC150	JISG5501
3	Deflector	Rubber (NR)		15	Square packing with valve seat	Rubber (NR)	
4	Deflector	Rubber (NR)		16	Square flange with valve seat	FC150	JISG5501
5	Casing cover	FC150	JISG5501	17	Plug	SWCH10K	JISG3539
6	Mechanical seal	-		18	Square packing	Rubber (NR)	
7	Shim	SUS304		19	Square flange	FC150	JISG5501
8	Key	SUS403	JISG4303	20	Plug	C3771BD	JISH3250
9	Impeller	PA6		21	Plug	C3771BD	JISH3250
10	Nut	SUS304	JISG4303	22	Base	FC150	JISG5501
11	Guide vane	PA6		23	Protection switch		Manually reset
12	O-ring	Rubber (NBR)					

3.2 Standard Accessories

Part No.	Part name	Q'ty	Application
87101040	Instruction Manual	1	

3.3 Optional Accessories

Part No.	Part name	Q'ty	Application
69050211	Heater	1	EH2-112 (200V-110W), Cable length 3m
28501010	Bushing	1	1x3/8 (CAC406)
56700110	Thermostat	1	ET6 (4°Cx12°C), Cable length 3m

[4] Installation

⚠ Warning

- Before hoisting the pump unit during unloading, positioning, and installation, check the product catalog, the installation drawing, and the operation manual, etc., to verify the pump unit weight and the hoist method. Do not attempt to hoist a pump unit that exceeds the hoist's rated load. Incorrect hoisting can result in drops and injuries.
- Securely install the pump as explained in the instruction manual. Incomplete installation could result in electric shock, fires or injury from dropping.

4.1 Installation Cautions

- (1) Use a nylon sling attached to the motor as shown in <Fig.1> when moving and positioning the pump unit onsite.
- (2) Install the pump unit in a horizontal posture, and secure it firmly with the anchor bolts. An uneven foundation (not horizontal) can cause base twisting damage.

4.2 Selecting the Installation Place

⚠ Caution

- Do not install this pump on a floor that has not been waterproofed and treated for drainage. Major disasters could occur if water leaks.
- Do not install the pump in a highly humid place such as a bathroom. Failure to observe this could result in electric shock should an earth leakage occur.
- Do not install this pump in places with high levels of dust. Failure to observe this could result in earth leakage or fires.

- (1) Install in a cool, well ventilated location which permits easy disassembly and assembly, and which is not exposed to rain or direct sunlight.
- (2) The installation site's ambient temperature must not exceed 40° C.
- (3) Install in a location which allows easy maintenance and inspection.
- (4) Install the pump as close to the water source as possible, where the suction height (height from suction fluid surface to center of pump) is low, and the horizontal distance of the suction pipe is as short as possible.
- (5) Keep the total suction head to within -8m.

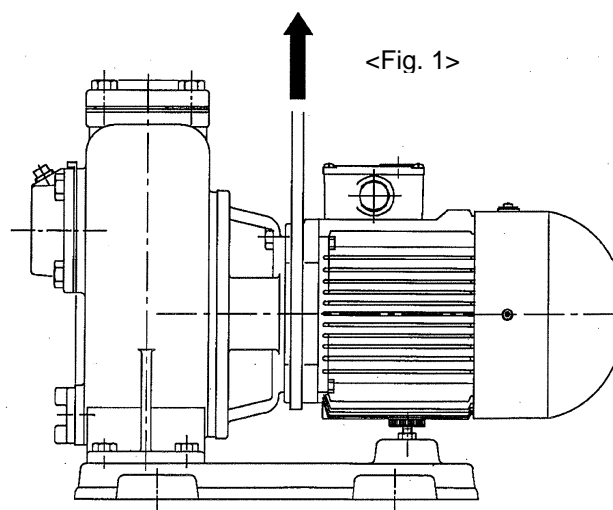

[5] Piping

⚠ Caution

- Foreign matter and sand, etc., must not be allowed to flow into the pump. Such matter can cause impeller lock conditions and mechanical seal damage.

5.1 Inflow Pipe

- (1) The pipe should be as short as possible, with no bends.
- (2) A strainer and sand filter should be installed in cases where foreign matter and sand, etc., are likely to be present in the water.
- (3) Lay the suction piping with a gradient (1/100 or more) leading upward toward the pump so that air traps do not form.
- (4) Do not install a sluice valve on the suction piping.

5.2 Discharge Pipe

- (1) Install a sluice valve near the discharge port for maintenance purposes.
- (2) Always install a check valve when the piping is long, when using automatic operation, or where the water is being fed to a pressure tank. The check valve should be installed between the pump body and the sluice valve.
- (3) A shockless valve, etc., should be installed in cases where there is a risk of water hammer conditions.
- (4) An exhaust valve should be installed in cases where air accumulation in the piping cannot be avoided.

5.3 Common Items

- (1) Install a vibration proof joint and piping support to prevent the piping weight from being applied directly to the pump.
- (2) Wrap the piping with insulating material to prevent freezing. A heater (special accessory), 1×3/8 bushing (special accessory) and thermostat (special accessory) should be mounted on the pump.

<Fig. 2>

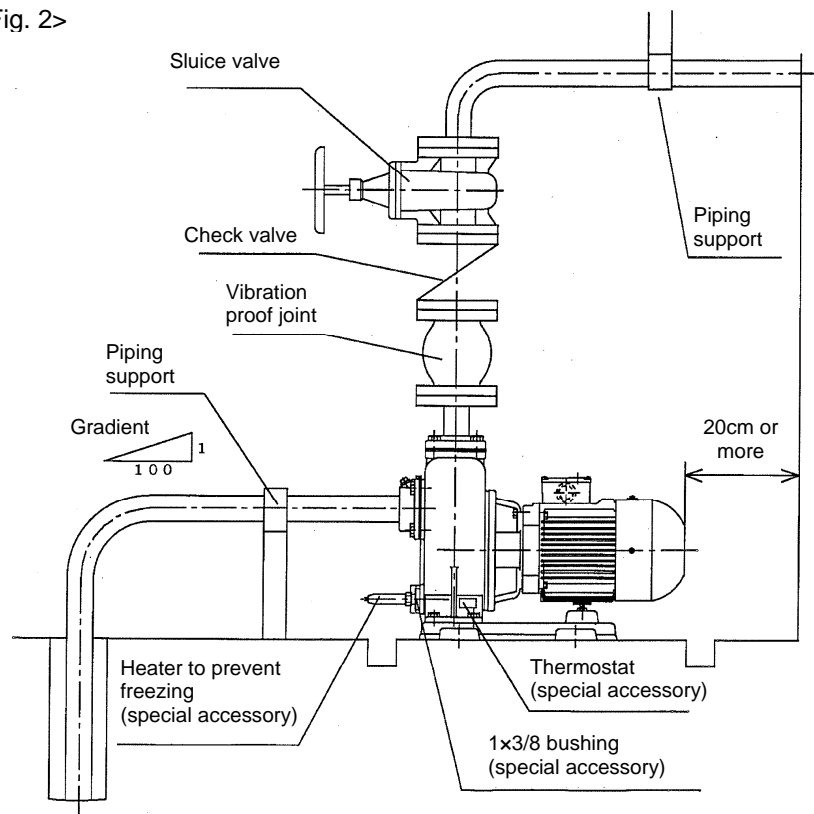

[6] Electrical Work

⚠ Warning

- The electrical work must be completed according to the "Electrical Installation Technical Standards", "Wiring Regulations" and any other applicable regulations. Improper wiring and connections could lead to earth leakage or fire.
- Securely earth the equipment, and install a dedicated earth leakage breaker. Failure to observe this could result in trouble, earth leakage and electric shock or fire.
- Always earth the pump before turning the power on. Do not connect the earthing wire to gas pipes, water pipes, lightning rods or telephone earthing wires. Failure to earth the equipment correctly could result in electric shocks.

6.1 Power Supply

- (1) Install an earth leakage breaker at the power supply.
- (2) Connect the power cable to the motor as shown in Fig. 3.

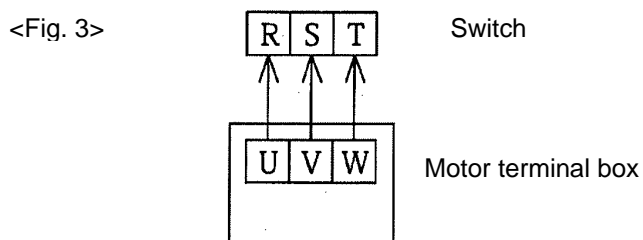

6.2 Ground

- (1) An earthing terminal is provided in the motor's terminal box as shown in <Fig. 4>, so always earth the motor. As shown in <Fig. 5>, grounding should be performed using either a copper plate 30cm square or larger, or a 1cm thick copper rod of 40cm or longer, buried to a depth of 30cm or more in a moist location. Always turn the source power supply OFF when handling the ground wire.

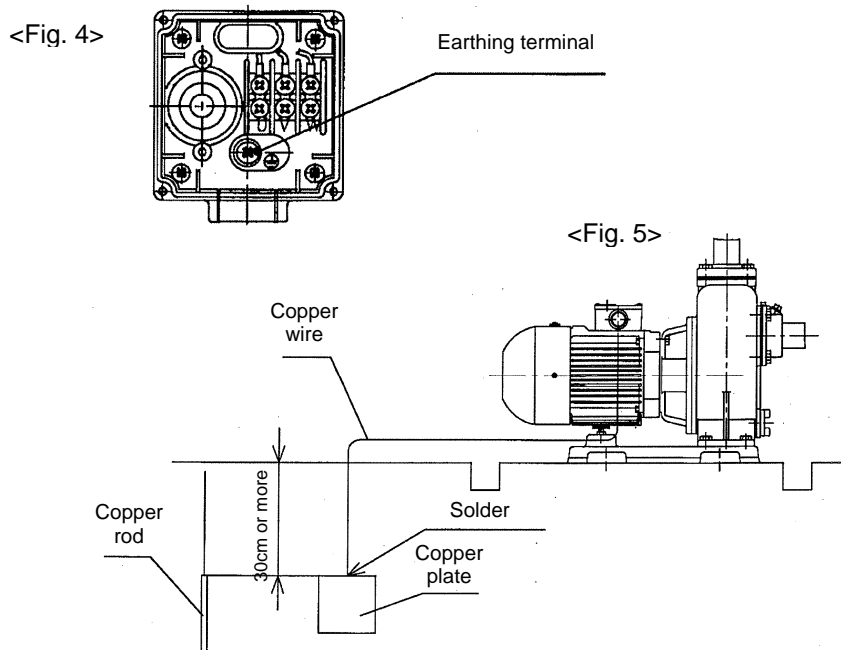

[7] Operation

⚠ Warning

- Always turn OFF the power and ensure that no power is being supplied to the pump when attaching or disconnecting wiring. Failure to observe this could result in electric shock.

⚠ Caution

- Do not use this product out of the rated voltage. Failure to observe this could result in fire or electric shock.
- Verify that the motor is rotating in the prescribed direction. Rotation in the wrong direction can cause water leakage, etc.
- Do not touch the rotating areas during operation, and do not insert fingers or rods, etc., into the motor openings. This could cause electrical shocks and injury.
- Do not touch the pump or motor during operation. The pump could reach high temperatures and lead to burns.
- Turn OFF the power when not using the pump for long periods of time. Failure to observe this could result in electric shock, earth leakage, or fire due to deterioration of the insulation.
- Do not run the pump in a dry mode (without water in the pump) or in a shutoff mode (without water inflow to, or discharge from, the pump). Such operations could cause the pump to become extremely hot, possibly resulting in burn injuries.

7.1 Before Operation

- (1) Verify that the earth leakage breaker capacity, the power supply voltage, and the wiring are correct.
- (2) Turn the pump by hand and confirm that it rotates easily. If the movement is stiff or uneven, inspect whether sand, etc., is caught inside. Turn the pump by inserting a screwdriver, etc., into the groove on the shaft end from the hole on the motor fan cover.
- (3) Prime the pump with the priming port. If the well level is deep, carry out additional priming. Operation in the dry mode could result in faults. When priming, rotate the pump to completely discharge the air from the impeller.

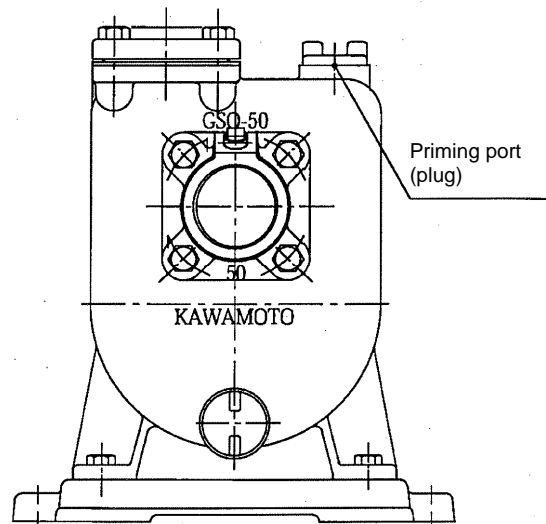

7.2 Trial Operation

- (1) After priming, close the sluice valve on the discharge side.
- (2) Turn the power ON, then turn the switch ON and OFF one or two times to verify the rotation direction (CW direction as viewed from motor side). If 3-phase rotation is reversed, turn the source power supply OFF, then switch the connections of 2 of the 3 wires.
- (3) If the system appears normal, gradually open the sluice valve at the discharge side to establish a continuous operation mode.
Verify that the voltage, current, vibration, and noise conditions, etc., are normal, and verify that there is no leakage from the mechanical seal.

7.3 Stopping Operation

- (1) When stopping operation, gradually close the sluice valve on the discharge side.

7.4 Standard Operation

- (1) The pressure gauge and compound gauge cocks should be closed except when performing measurements. Leaving these cocks open will increase the risk of damage.

[8] Maintenance and Inspection

Warning

- If the pump does not operate or if an abnormality is sensed (such as a burning smell), stop operation immediately and turn OFF the main power. Then, contact the place of purchase or a designated Kawamoto Pump service center for inspections and repairs. Failure to do so could result in electric shock, fire, earth leakage, etc.
- Always turn the power OFF and make sure that power is not being supplied before starting maintenance servicing. Failure to observe this could result in electric shock.

8.1 Daily Inspection

Check Item		Determination Reference
Mechanical seal		There must be no dripping (leakage) from the seal.
Motor	Surface temperature	Ambient temperature + 70°C
	Ball-bearing	Operation noise & vibration should be unchanged from initial condition.
Pressure		No increase from the normal pressure.
Current		Nameplate rated current value or less.
Voltage		Within $\pm 10\%$ of rated voltage

Daily inspections are essential for detecting problems quickly. The maintenance of a daily operation log is therefore recommended.

8.2 Consumable parts

The following parts are consumable parts. Refer to the replacement guidelines and replace the parts.

Part No.	Part name	Replacement guideline	Application
31701510	Square packing with valve seat 50	At each disassembly and inspection	Casing x square flange with valve seat (suction side)
31200710	Square flange packing 50		Casing x square flange (discharge side)
30400559	O-ring P70	At each disassembly and inspection	Casing x Casing cover
30400314	O-ring K190		Casing x guide vane
30002710	Mechanical seal 20	1 year	
	Ball-bearing	3 years	Motor

List of applicable totally-enclosed fan-cooled type bearings

Output (kW)	Pump side	Opposite pump side
0.4	6204ZZC3	6203ZZC3AC
0.75	6305ZZC3	6303ZZC3
1.5	6306ZZC3	6303ZZC3

All consumable parts are subject to change without notice.

[9] Disassembly and Assembly

Warning

- This product must never be disassembled, repaired or modified by any person other than a qualified repair technician. Improper repairs could lead to electric shocks, fires or water leaks.
- When desiring to reinstall the pump in a new location, please contact either the vendor where the Deep well submersible pump was purchased, or an authorized Kawamoto Pump service agency, for assistance. Improper installation could lead to electric shocks, fires or water leaks.

9.1 Before Disassembling

- (1) Turn the source power supply OFF.
- (2) Close the sluice valves at the discharge side.
- (3) Drain (at drain port) all water from the pump.

9.2 Mechanical Seal Replacements: Refer to <Fig. 6>.

- (1) Remove the bolt (a) which is fixing the casing and casing cover, and separate the motor section.
- (2) Remove the guide vane (b).
- (3) Remove the impeller nut (c).
- (4) Remove the parts in order from the front (flat washer, impeller, shim, etc.), and remove the mechanical seal (d) last.
- (5) Attach a new mechanical seal. Wet the periphery of the cushion rubber to facilitate insertion. Take care not to damage the sliding surface when inserting the mechanical seal. If any dirt or dust is on the parts, wipe it off completely.
- (6) Reassemble in the reverse order of the disassembly procedure.
- (7) Replace the O-ring (e) with a new item.
- (8) After reassembling, verify that the main shaft turns without obstruction.

9.3 Ball-Bearing Replacement: Refer to <Fig. 6>.

- (1) In the same manner as the mechanical seal replacement procedure, disassemble down to the mechanical seal level.
When removing the mechanical seal, use care to avoid scratching the slideway.
- (2) Remove the bolt (f) which is fixing the motor and casing cover.
- (3) Remove the motor, and have the ball bearings replaced by a specialist.
- (4) Reassemble in the reverse order of the disassembly procedure.
- (5) Replace the O-ring (e) with a new item.
- (6) After reassembling, verify that the main shaft turns without obstruction.

<< Purchase replacement parts from your dealer. >>

<Fig. 6>

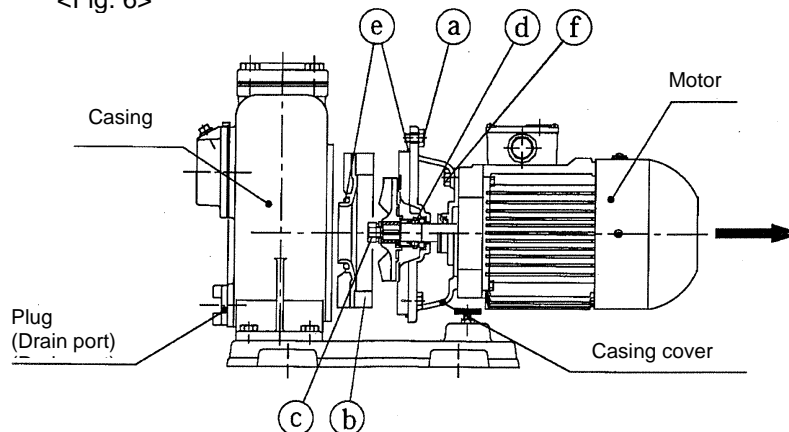

[10] Troubleshooting

Problem	Cause	Countermeasure	Manual page No.
Pump does not run	Power supply problem.	Inspect and repair.	7
	Single-phase connection is being used (for 3-phase).	Correct the wiring.	6
	Foreign matter embedded in slideway.	Remove the foreign matter.	9
	Rust at rotating area.	Disassemble and repair.	9
	The protection switch has activated.	Disassemble, repair and remove cause. Then, press reset button.	9
Pump rotates, but no water is discharged. Prescribed discharge amount/pressure is not obtained.	Sluice valve is closed.	Open the sluice valve.	7
	The pump is insufficiently primed.	Prime, and fill the pump with water.	7
	The suction pipe does not reach the water	Extend the suction pipe so it is submerged in the water	5
	Impeller is clogged with foreign matter.	Remove the foreign matter.	9
	Pump rotation direction is reversed.	Correct the wiring.	6
	Worn parts.	Replace the worn parts.	9
Overload (over-current) occurs	Voltage drop, or unbalanced phase conditions exist.	Check the power supply.	2, 7
	Obstruction at rotating area. Shaft is bent.	Request repair from a facility specializing in this procedure.	7
Pump vibrates/abnormal noise	Improper installation.	Check the installation condition.	5
	Clogged impeller.	Remove the foreign matter.	9
	Pump rotation direction is reversed.	Correct the wiring.	6
	Obstruction at rotating area. Shaft is bent.	Request repair from a facility specializing in this procedure.	7
	The motor's ball-bearings are worn.	Request repair from a facility specializing in this procedure.	8, 9
Water leakage occurs	Damaged mechanical seal.	Replace the mechanical seal.	9
	Damaged O-ring.	Replace the O-ring.	9

◎ The pump may emit a squeaking sound at starts and stops, but this is normal.

Unexpected trouble could occur. However, it is important to take appropriate measures immediately when an abnormal condition is found. If the cause of the trouble is not clear, contact your dealer or designated service center. Notice the pump type, serial No. and trouble (fault) state making an inquiry.

Kawamoto Pump Mfg. Co., Ltd.

Head office: No. 11-39 4-chome Ohsu Naka-ku Nagoya, 460-8650 Japan