

Uniting water with an abundant lifestyle Kawamoto Pump

Centrifugal pump

GES-C Type Instruction Manual

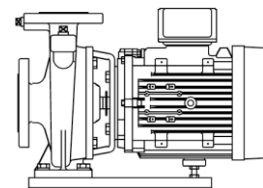

Thank you for purchasing the GES-C Type Centrifugal Pump.
 This instruction manual provides information for the construction company to safely use this pump unit, and for handlers of fire prevention targets to carry out maintenance and inspection, etc. Always read this manual thoroughly and fully comprehend the contents before starting work.
 Please keep this instruction manual in a handy place for quick reference.

<Contents>

[1] Introduction.....	2	[6] Electrical Work.....	6
[2] Specifications.....	2	[7] Operation.....	7
[3] Product Configuration.....	3	[8] Maintenance and Inspection	8
[4] Installation.....	4	[9] Disassembly and Assembly.....	10
[5] Piping.....	5	[10] Troubleshooting	11

Special Notes

1. Securely earth the equipment, and install a dedicated residual current circuit breaker. Failure to observe this could result in trouble, electric shock or fire.
2. The electrical work must be completed according to the "Electrical Installation Technical Standards", "Wiring Regulations" and any other applicable regulations. Improper wiring and connections could lead to electric shock or fire.
3. Do not run the pump in a dry mode (without water in the pump) or in a shutoff mode (without water inflow to, or discharge from, the pump). Such operations could cause the pump to become extremely hot, possibly resulting in burn injuries.
4. Do not install the pump that is not waterproof or that has not drainage facility. Major disasters could occur if water leaks.

Precautions for using this product safely and for preventing personal injuries or physical damage are given in this manual.

The precautions are classified as "Warning" and "Caution" to alert of the degree of injury or damage that could occur if handling is mistaken.

In either case, these are important matters related to safety, and must be observed.



Warning : Details which if ignored could lead to fatalities or serious injuries.



Caution : Details which if ignored could lead to personal injuries or physical damage.

(Note) The conventional unit and values based on these given in parentheses are provided as reference.

[1] Introduction

Please check the following items upon receipt of the product.

- (1) Check the nameplate to ensure that the correct pump has been delivered. (Model etc.)
- (2) Check that no parts have been damaged during transportation, and that none of the bolts, nuts, etc., are loose. Tighten any part that is loose.

<<If there is any problems, contact your dealer>>

[2] Specifications

Caution

- Always use this pump within the specified product specifications.
Failure to do so could result in electric shock, fire, residual currents, etc.

2.1 Specifications

Pumped, fluid	Fluid quality	Fresh water (PH 6.5 to 8)
	Fluid temp.	0 to 90°C
Installation location		Indoor
Ambient temp./humidity		0 to 40°C/90% RH or less
Suction total head		Within -6m (20°C)
Max. working pressure		1MPa {10.2kgf/cm ² }
Permissible back pressure		(1- shutoff pressure) MPa {(10.2 – shutoff pressure) kgf/cm ² }
Motor	Type	Enclosed fan-cooled outdoor type 2-pole
	Phase	3-phase
	Voltage	50Hz: 400、415V 60Hz: 400V

[3] Product Configuration

3.1 Structure

The drawing below represents a typical example of a GES-C Type Centrifugal Pump and may differ slightly depending on the model.

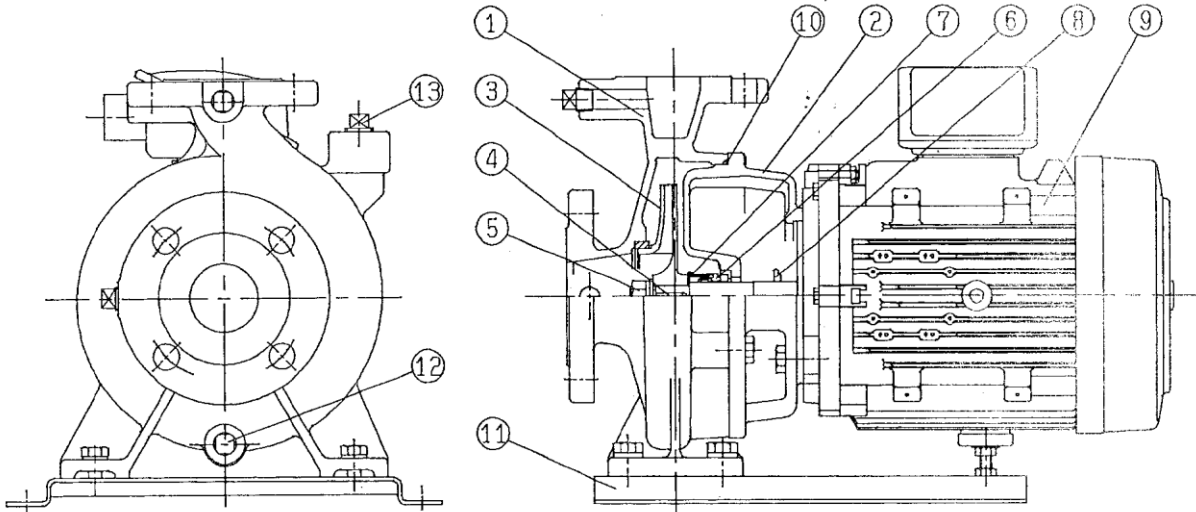

No.	Name	Qty.	No.	Name	Qty.	No.	Name	Qty.
1	Casing	1	6	Mechanical seal	1	11	Base	1
2	Casing cover	1	7	Spring bracket	1	12	Plug	1
3	Impeller	1	8	Deflector	1	13	Plug	1
4	Key	1	9	Motor	1			
5	Nut	1	10	O-ring	1			

3.2 Optional Accessories

Part No.	Part name	Application
19800210	Priming funnel	When using for suction with GES-65.
03710110	Stop valve	
09681620	Flange set 32-10K	
09680020	Flange set 40-10K	
09680220	Flange set 50-10K	
09680420	Flange set 65-10K	
09680620	Flange set 80-10K	

[4] Installation

Warning

- Before hoisting the pump unit during unloading, positioning, and installation, check the product catalog, the installation drawing, and the instruction manual, etc., to verify the pump unit weight and the hoist method. Do not attempt to hoist a pump unit that exceeds the hoist's rated load. Incorrect hoisting can result in drops and injuries.
- Securely install the pump as explained in the instruction manual. Incomplete installation could result in electric shock, fires or injury from dropping.

4.1 Installation Cautions

- (1) Use a nylon sling attached to the inflow side's flange and the motor as shown in Fig.1 when moving and positioning the pump unit onsite.
- (2) Install the pump unit in a horizontal posture, and secure it firmly with the foundation bolts. (The foundation bolts must be purchased separately.)
An uneven foundation (not horizontal) can cause base twisting damage.

4.2 Selecting the Installation Place

Caution

- Do not install this pump on a floor has not been waterproofed and treated for drainage. Major disasters could occur if water leaks.
- Do not install the pump in a highly humid place such as a bathroom. Failure to observe this could result in electric shock should a residual current occur.
- Do not install this pump in places such as machine and chemical factories where toxic gases including acid, alkaline, organic solvents or paint are present, where gases containing corrosive elements are generated, or where there are high levels of dust. Failure to observe this could result in residual currents or fires.

- (1) Install in a cool, well ventilated location which permits easy disassembly and assembly, and which is not exposed to rain or direct sunlight.
- (2) The installation site's ambient temperature must not exceed 40°C.
- (3) Install in a location which allows easy maintenance and inspection.
- (4) Install the pump as close to the water source as possible, where the suction height (height from suction fluid surface to center of pump) is low, and the horizontal distance of the suction pipe is as short as possible.
- (5) Keep the total suction head to within -6m. Note that when pumping hot water (40°C or more), the total head must be compensated as shown on the right.

(Example) Fluid temperature 90°C

Suction total head = -6 + 7.5 = 1.5(m) ... Positive suction 1.5m

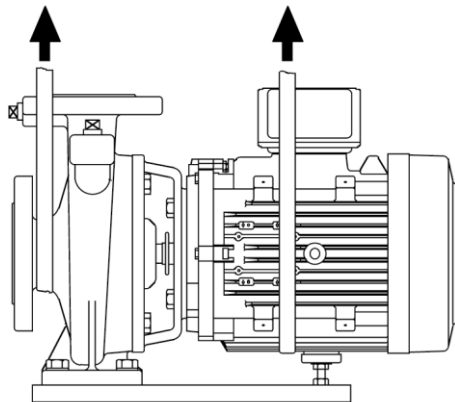

<Fig. 1>

<Compensation value of fresh water exceeding 40°C>

Temp. (°C)	Compensation value
50	+1.5
60	+2.0
80	+5.0

[5] Piping

⚠ Caution

- Foreign matter and sand, etc., must not be allowed to flow into the pump. Such matter can cause impeller lock conditions and mechanical seal damage.

5.1 Inflow Pipe

<Common>

- (1) The pipe should be as short as possible, with no bends.
- (2) A strainer and sand filter should be installed in cases where foreign matter and sand, etc., are likely to be present in the water.

<Suction>: Refer to Fig. 2

- (1) The end of the suction piping must be two or more times deeper than the pipe diameter (D), and separated by 30cm or more from the bottom and walls.
- (2) Attach a foot valve to the end of the suction piping.
- (3) Lay the suction piping with a gradient (1/100 or more) leading upward toward the pump so that air traps do not form.
- (4) Do not install a sluice valve on the suction piping.
- (5) Set the suction piping bore and coupling reducer's size as shown in <Table 1>. Install the coupling reducer so that air traps do not form.

<Table 1>

Pump bore	Foot valve
40	40
50	50
65	65

<Negative pressure, positive pressure>: Refer to Fig. 3

- (1) Install a sluice valve near the suction inlet for maintenance.

5.2 Discharge Pipe

- (1) Install a sluice valve near the discharge port for maintenance purposes.
- (2) Be sure to install a check valve in cases where the pipe is long, where the actual head is high, where automatic operation occurs, where water is being fed to a pressure tank, and where 2 or more pumps are running in a parallel format. The check valve should be installed between the pump body and the sluice valve.
- (3) A shockless valve, etc., should be installed in cases where there is a risk of water hammer conditions.
- (4) An exhaust valve should be installed in cases where air accumulation in the piping cannot be avoided.

5.3 Common Items

- (1) Install a vibration proof joint and piping support to prevent the piping weight from being applied directly to the pump.
- (2) Wrap the piping with insulating material to prevent freezing. The use of a pump heater is recommended. (The pump has a flange for connecting the optional heater.)

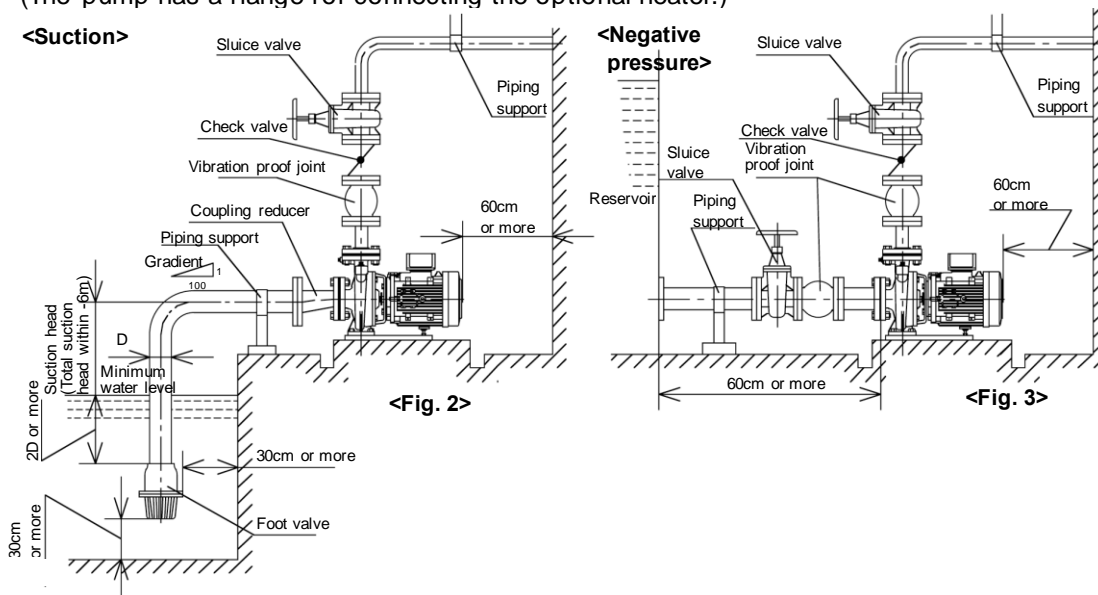

[6] Electrical Work

⚠ Warning

- The electrical work must be completed according to the "Electrical Installation Technical Standards", "Wiring Regulations" and any other applicable regulations.
Improper wiring and connections could lead to electric shock or fire.
- Securely earth the equipment, and install a dedicated residual current circuit breaker.
Failure to observe this could result in trouble, electric shock or fire.
- Always earth the pump before turning the power on.
Do not connect the earthing wire to gas pipes, water pipes, lightning rods or telephone earthing wires.
Failure to earth the equipment correctly could result in electric shocks.

6.1 Power Supply

- (1) Refer to the following table and install an earth leakage breaker on the power supply and an overload protection unit for the motor.
If the voltage fluctuates, the current value will also fluctuate.

<Rated current>

Unit: A

Pump output (kW)	3-phase	
	50Hz	60Hz
0.75	3.6	3.5
1.5	6.5	6.5
2.2	9.3	9.1
3.7	15.3	14.6
5.5	22.3	21.6
7.5	29.2	28.9

6.2 Ground

- (1) There is a ground terminal in the motor terminal box, so ground with Class D (Class 3) grounding.
Perform the necessary ground connection work for the ground terminal in the motor's terminal box. As shown in Fig.4, grounding should be performed using either a copper plate 30cm square or larger, or a 1cm thick copper rod of 40cm or longer, buried to a depth of 30cm or more in a moist location.
Always turn the source power supply OFF when handling the ground wire.

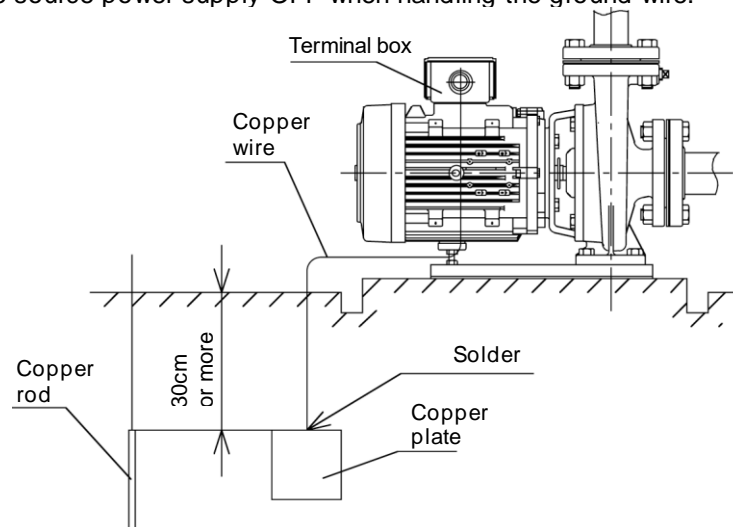

<Fig. 4>

[7] Operation

⚠ Warning

- Always turn OFF the power and ensure that no power is being supplied to the pump when attaching or disconnecting wiring. Failure to observe this could result in electric shock.

⚠ Caution

- Do not use this product out of the rated voltage. Failure to observe this could result in fire or electric shock.
- Verify that the motor is rotating in the prescribed direction. Rotation in the wrong direction can cause water leakage, etc.
- Do not touch the rotating areas during operation, and do not insert fingers or rods, etc., into the motor openings. This could cause electrical shocks and injury.
- Do not touch the pump or motor during operation. The pump could reach high temperatures and lead to burns.
- Turn OFF the power when not using the pump for long periods of time. Failure to observe this could result in electric shock, short circuit, or fire due to deterioration of the insulation.
- Do not run the pump in a dry mode (without water in the pump) or in a shutoff mode (without water inflow to, or discharge from, the pump). Such operations could cause the pump to become extremely hot, possibly resulting in burn injuries.

7.1 Before Operation

- (1) Verify that the earth leakage breaker capacity, the power supply voltage, and the wiring are correct.
- (2) Turn the pump by hand and confirm that it rotates lightly. Stiff or uneven rotation can be caused by internal rust, etc., and the pump should be inspected in such cases. Turn by hand, or remove the fan cover's rubber bushing and turn the shaft end with a flat-tip screwdriver.
- (3) The pump must be primed. Do not perform dry operation, as this can cause a pump failure.

When priming the pump, turn it by hand to remove all the air from the impeller.

<Suction> : Prime with the priming port or priming funnel.

<Positive pressure or negative pressure> : Open the sluice valves at the inflow and discharge sides, then prime the pump.

- (4) Attach the fan cover's rubber bushing.

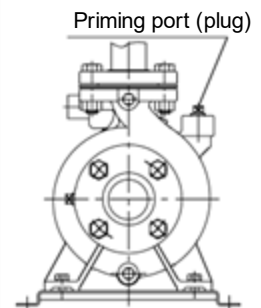

7.2 Trial Operation

- (1) After priming the pump, close the sluice valve at the discharge side, and fully open the sluice valve at the inflow side.
- (2) Turn the power ON, then turn the switch ON and OFF one or two times to verify the rotation direction (CW direction as viewed from motor side). If 3-phase rotation is reversed, turn the source power supply OFF, then switch the connections of 2 of the 3 wires.
- (3) If the system appears normal, gradually open the sluice valve at the discharge side to establish a continuous operation mode.
Verify that the voltage, current, vibration, and noise conditions, etc., are normal, and verify that there is no leakage from the mechanical seal.

7.3 Stopping Operation

- (1) If there is no check valve at the discharge side, operation should be stopped while gradually closing the discharge side sluice valve.

7.4 Standard Operation

- (1) The pressure gauge and compound gauge cocks should be closed except when performing measurements. Leaving these cocks open will increase the risk of damage.

[8] Maintenance and Inspection

Warning

- If the pump does not operate or if an abnormality is sensed (such as a burning smell), stop operation immediately and turn OFF the main power. Then, contact the place of purchase or a designated Kawamoto Pump service center for inspections and repairs. Failure to do so could result in electric shock, fire, residual currents, etc.
- Always turn the power OFF and make sure that power is not being supplied before starting maintenance servicing. Failure to observe this could result in electric shock.

8.1 Daily Inspection

Check Item		Determination Reference
Mechanical seal		There must be no dripping (leakage) from the seal.
Motor	Surface temperature	Ambient temperature + 75°C
	Ball-bearing	Operation noise & vibration should be unchanged from initial condition.
Pressure		No increase from the normal pressure.
Current		Nameplate rated current value or less.
Voltage		Within ±10% of rated voltage

Daily inspections are essential for detecting problems quickly. The maintenance of a daily operation log is therefore recommended.

8.2 Consumable parts

The following parts are consumable parts. Refer to the replacement guidelines and replace the parts.

8.2.1 O-ring

Pump type	Part No.	Part name	Replacement guideline
GES-40 (5-0.75 6-1.5)	30400311	O-ring K160	At each disassembly inspection
GES-50 (5-1.5 6-2.2)			
GES-40 (5-1.5, 2.2 6-2.2, 3.7)	30400313	O-ring K180	
GES-65 (5-3.7 6-5.5, 7.5)			
GES-50 (5-2.2, 3.7 6-3.7, 5.5)	30400314	O-ring K190	
GES-50 (5-5.5 6-7.5)	30400317	O-ring K220	
GES-65 (5-5.5, 7.5)			

8.2.2 Mechanical seal

Motor output	Part No.	Part name	Replacement guideline
3.7kW or less	30004620	Mechanical seal 20	1 year
7.5kW or less	30004720	Mechanical seal 25	

8.2.3 Ball-bearing

Motor output	Position	Part No.	Name	Replacement guideline
0.75kW	Load side	35201915	Ball-bearing 6305ZZC3	1 year
	Opposite load side	35201913	Ball-bearing 6303ZZC3	
1.5kW	Load side	35201916	Ball-bearing 6306ZZC3	
	Opposite load side	35201913	Ball-bearing 6303ZZC3	
2.2kW 3.7kW	Load side	35201917	Ball-bearing 6307ZZC3	
	Opposite load side	35201916	Ball-bearing 6206ZZC3	
5.5kW	Load side	35201919	Ball-bearing 6309ZZC3	
	Opposite load side	35201917	Ball-bearing 6207ZZC3	
7.5kW	Load side	35201920	Ball-bearing 6310ZZC3	
	Opposite load side	35201917	Ball-bearing 6207ZZC3	

[9] Disassembly and Assembly

Warning

- This product must never be disassembled, repaired or modified by any person other than a qualified repair technician. Improper repairs could lead to electric shocks, fires or water leaks.
- When desiring to reinstall the pump in a new location, please contact either the vendor where the Deep well submersible pump was purchased, or an authorized Kawamoto Pump service agency, for assistance. Improper installation could lead to electric shocks, fires or water leaks.

9.1 Before Disassembling

- (1) Turn the source power supply OFF.
- (2) Close the sluice valves at the inflow and discharge sides.
- (3) Drain (at drain port) all water from the pump.

9.2 Mechanical Seal Replacements: Refer to Fig. 5.

- (1) Remove the bolt (a) which is fixing the casing and casing cover, and separate the motor section.
- (2) Remove the impeller nut (b).
- (3) Remove the parts in order from the front (spring washer, flat washer, impeller, key, spring bracket), and remove the mechanical seal (c) last.
- (4) Attach a new mechanical seal. Wet the periphery of the cushion rubber to facilitate insertion. When inserting the mechanical seal, use care to avoid scratching the slideway. Also be sure to wipe away any foreign matter or dust which may be adhered to the seal.
- (5) Reassemble in the reverse order of the disassembly procedure.
- (6) Replace the O-ring (d) with a new item.
- (7) After reassembling, verify that the main shaft turns without obstruction.

9.3 Ball-Bearing Replacement: Refer to Fig. 5.

- (1) In the same manner as the mechanical seal replacement procedure, disassemble down to the mechanical seal level. When removing the mechanical seal, use care to avoid scratching the slideway.
- (2) Remove the bolt (e) which is fixing the motor and casing cover.
- (3) Remove the motor, and have the ball bearings replaced by a specialist.
- (4) Reassemble in the reverse order of the disassembly procedure.
- (5) Replace the O-ring (d) with a new item.
- (6) After reassembling, verify that the main shaft turns without obstruction.

<<Purchase replacement parts from your dealer>>

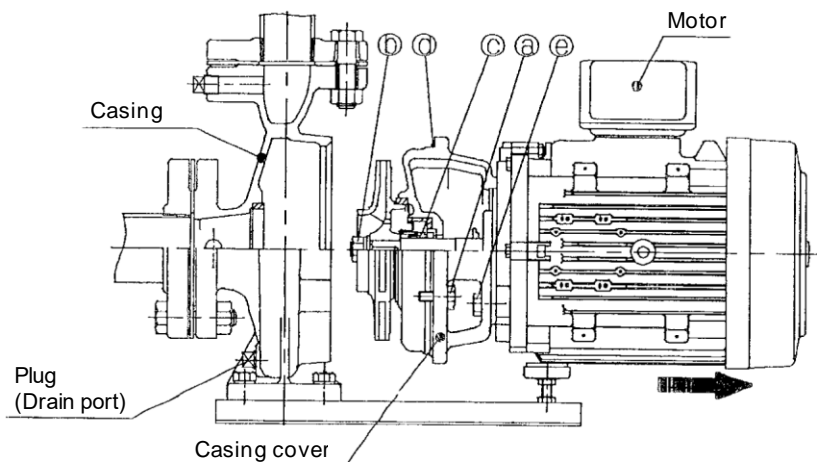

<Fig. 5>

[10] Troubleshooting

Problem	Cause	Countermeasure	Manual page No.
Pump does not run	Power supply problem.	Inspect and repair.	7
	Single-phase connection is being used (for 3-phase).	Correct the wiring.	6
	Foreign matter embedded in slideway.	Remove the foreign matter.	10
	Rust at rotating area.	Disassemble and repair.	10
Pump rotates, but no water is discharged. Prescribed discharge amount/pressure is not obtained.	Sluice valve is closed.	Open the sluice valve.	7
	The pump is insufficiently primed.	Prime, and fill the pump with water.	7
	The suction pipe does not reach the water	Extend the suction pipe so it is submerged in the water	5
	Impeller is clogged with foreign matter.	Remove the foreign matter.	10
	Pump rotation direction is reversed.	Correct the wiring.	6
	Worn parts.	Replace the worn parts.	10
Overload (over-current) occurs	Voltage drop, or unbalanced phase conditions exist.	Check the power supply.	2, 7
	Obstruction at rotating area. Shaft is bent.	Request repair from a facility specializing in this procedure.	7
Pump vibrate 1s/abnormal noise	Improper installation.	Check the installation condition.	4
	Clogged impeller.	Remove the foreign matter.	10
	Pump rotation direction is reversed.	Correct the wiring.	6
	Obstruction at rotating area. Shaft is bent.	Request repair from a facility specializing in this procedure.	7
	The motor's ball-bearings are worn	Request repair from a facility specializing in this procedure.	9, 10
Water leakage occurs	Damaged mechanical seal.	Replace the mechanical seal.	10
	Damaged O-ring.	Replace the O-ring.	10

© The pump may emit a squeaking sound at starts and stops, but this is normal.

Unexpected trouble could occur. However, it is important to take appropriate measures immediately when an abnormal condition is found. If the cause of the trouble is not clear, contact your dealer or designated service center. Notice the pump type, serial No. and trouble (fault) state making an inquiry.

Kawamoto Pump Mfg.Co.,Ltd.

Head office: No. 11-39 4-chome, Ohsu Naka-ku Nagoya, 460-8650 Japan

No.	87103823
-----	----------