

GE-2M

**KAWAMOTO END SUCTION CENTRIFUGAL PUMP
2 POLES / 50 Hz
SUCTION SIZE 40 ~ 100 MM**



APPLICATIONS AND FEATURES

■ APPLICATIONS

- Cold and hot water circulation
- Cooling water for building and factory equipment
- Agriculture
- Industry
- Other general water supply
(Please inquire in case drinking water application)

■ FEATURES

- Compact and light weight.
- Easy maintenance and inspection due to back pull out construction.
- Long life mechanical seal is adopted for shaft sealing.
- Simple end suction top centerline discharge position enable steady installation with high discharge pipe loading.
- Wide application for various usages.
- In accordance with Japanese industrial standard (JIS B8313).

STANDARD SPECIFICATIONS

Description		Model : GE-2M
Liquid	Name	Clean water
	Temperature	0 ~ 90 °C
Max Working Pressure		10 bar
Synchronous Speed		3000 min ⁻¹
Installation		TEFC outdoor use (Motor IP55, Class F)
Material	Casing	Cast iron (FC200)
	Impeller	Cast iron (FC200), Bronze (CAC406) or Stainless Cast iron (SCS13)
	Shaft	Stainless steel (SUS403)
Construction	Impeller	Closed
	Shaft Seal	Mechanical seal (SIC × Carbon × FKM)
		Gland packing (PTFE-non asbestos)
	Sealing	None
Bearing	Sealed ball bearing	
Flange		JIS 10K
Baseplate		Cast iron (FC150)

OPTIONAL SPECIFICATIONS

Description		Model : GE-2M
Material	Casing	Cast iron + Nylon coating
	Impeller	SCS14 (SUS316) 40×32 : 0.4~2.2kw 50×40 : 0.4~5.5kw 65×50 : 2.2~3.7kw 80×65 : 2.2~7.5kw 100×80 : 7.5~11kw
	Shaft	Stainless steel (SUS316)
Construction	Impeller	Closed
	Shaft Seal	Mechanical seal (SIC × SIC × FKM)
	Sealing	None
	Bearing	Sealed ball bearing
Flange		JIS 10K
Baseplate		Channel baseplate for European motor bland
Anti-corrosion Painting		Urethane resin coating + non touch seal bearing structure
		Epoxy resin coating

PERFORMANCE CHART

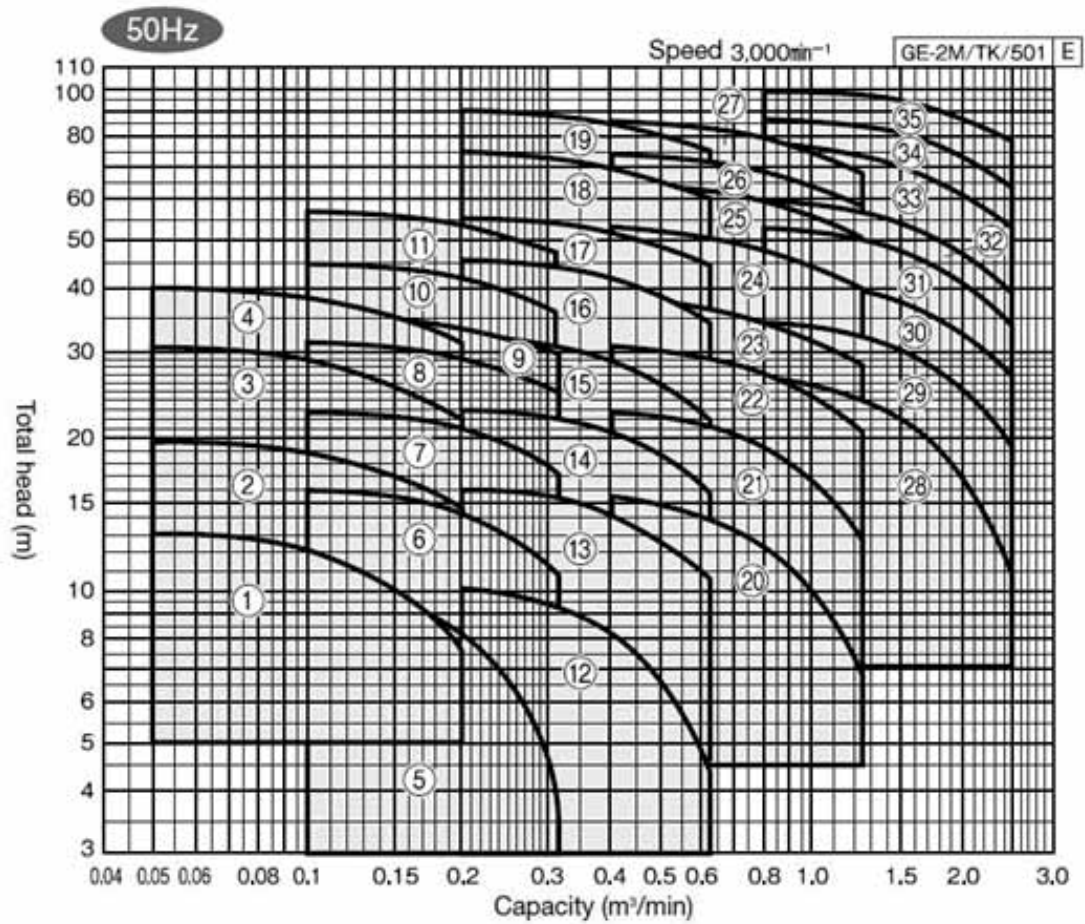

MODEL CODE

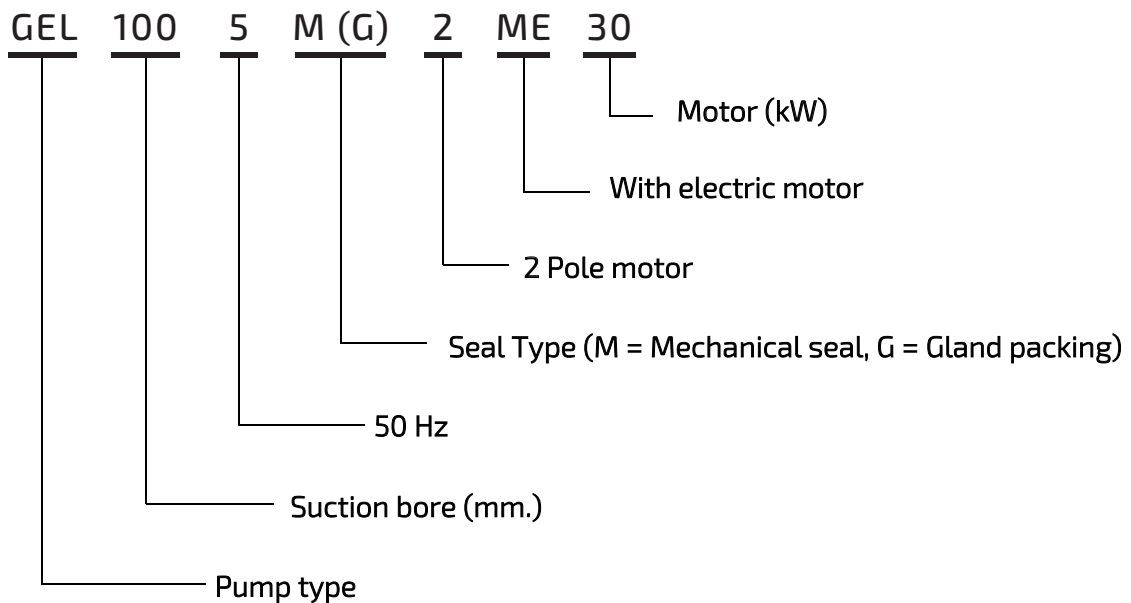

SPECIFICATION TABLE

No.	Model	Motor (kW)	Performance				Back Pressure Mpa {kgf/cm ² }
			Capacity (m ³ /min)	Head (m)	Capacity (m ³ /min)	Head (m)	
1	GEH-40×325M-2MN0.4	0.4	0.05	13	0.2	7.5	0.84
2	GEI405M2ME0.75	0.75	0.05	19.8	0.2	14.5	0.77
3	GEJ405M2ME1.5	1.5	0.05	30.5	0.2	22	0.67
4	GEJ405M2ME2.2	2.2	0.05	40	0.2	31.5	0.58
5	GEH-50×405M-2MN0.4	0.4	0.1	10.5	0.32	3.5	0.86
6	GEH505M2ME0.75	0.75	0.1	15.8	0.32	10.5	0.81
7	GEI505M2ME1.5	1.5	0.1	22.5	0.32	17	0.74
8	GEJ505M2ME2.2	2.2	0.1	31	0.32	24.5	0.67
9	GEJ505M2ME3.7	3.7	0.1	35.5	0.32	29.8	0.63
10	GEK505M2ME3.7	3.7	0.1	44.5	0.32	35.5	0.52
11	GEK505M2ME5.5	5.5	0.1	56.5	0.32	47	0.39
12	GEH655M2ME0.75	0.75	0.2	10	0.63	4.2	0.87
13	GEH655M2ME1.5	1.5	0.2	15.8	0.63	10.5	0.81
14	GEI655M2ME2.2	2.2	0.2	22.8	0.63	15.2	0.74
15	GEJ655M2ME3.7	3.7	0.2	32.5	0.63	21	0.65
16	GEK655M2ME5.5	5.5	0.2	45	0.63	34	0.52
17	GEK655M2ME7.5	7.5	0.2	54.5	0.63	43.5	0.42
18	GEL655M2ME11	11	0.2	75	0.63	59.5	0.22
19	GEL655M2ME15	15	0.2	90	0.63	74	0.059
20	GEH805M2ME2.2	2.2	0.4	15.2	1.25	6.5	0.81
21	GEI805M2ME3.7	3.7	0.4	22.5	1.25	12	0.74
22	GEJ805M2ME5.5	5.5	0.4	30.5	1.25	20	0.66
23	GEJ805M2ME7.5	7.5	0.4	38.5	1.25	27.5	0.58
24	GEK805M2ME11	11	0.4	52	1.25	38.5	0.45
25	GEK805M2ME15	15	0.4	63.5	1.25	49.5	0.33
26	GEL805M2ME18	18.5	0.4	74	1.25	57	0.32
27	GEL805M2ME22	22	0.4	85	1.25	67	0.13
28	GEI1005M2ME7.5	7.5	0.8	26.5	2.5	10.5	0.69
29	GEJ1005M2ME11	11	0.8	34	2.5	19	0.62
30	GEJ1005M2ME15	15	0.8	42	2.5	27	0.54
31	GEK1005M2ME18	18.5	0.8	52.5	2.5	33	0.44
32	GEK1005M2ME22	22	0.8	59	2.5	38.5	0.37
33	GEL1005M2ME30	30	0.8	76	2.5	51.5	0.22
34	GEL1005M2ME37	37	0.8	86	2.5	64.5	0.098
35	GEL1005M2ME45	45	0.8	99	2.5	77	0

PUMP DATA

No.	Model	Impeller	Mechanical Seal	Gland Packing	Bearing		Coupling	Key	Back Pressure Mpa {kgf/cm ² }
					Motor	Pump			
1	GEH-40×325M-2MNO.4	FC	Ø16 EA560H-16N	Ø16 × Ø28 × 6.4 × 3	6204ZZ	6204ZZ	Ø63 × Ø19 × Ø14	6 × 6 × 20	0.84 {8.6}
2	GEI405M2ME0.75						Ø63 × Ø19 × Ø19		0.77 {7.9}
3	GEJ405M2ME1.5	CAC406(BC6)	Ø20 EA560H-20N	Ø20 × Ø36 × 8.5 × 4	6204ZZ	6204ZZ	Ø74 × Ø19 × Ø24	6 × 6 × 32	0.67 {6.8}
4	GEJ405M2ME2.2						Ø63 × Ø19 × Ø14		0.58 {5.9}
5	GEH-50×405M-2MNO.4	FC	Ø16 EA560H-16N	Ø16 × Ø28 × 6.4 × 3	6304ZZ	6304ZZ	Ø63 × Ø19 × Ø19	6 × 6 × 20	0.86 {8.8}
6	GEH505M2ME0.75						Ø63 × Ø19 × Ø19		0.81 {8.3}
7	GEI505M2ME1.5	FC	Ø20 EA560H-20N	Ø20 × Ø36 × 8.5 × 4	6304ZZ	6304ZZ	Ø100 × Ø19 × Ø24	6 × 6 × 32	0.74 {7.6}
8	GEJ505M2ME2.2						Ø112 × Ø19 × Ø28		0.67 {6.8}
9	GEJ505M2ME3.7	CAC406(BC6)	Ø25 EA560H-25N	Ø25 × Ø41 × 8.5 × 4	6305ZZ	6305ZZ	Ø112 × Ø24 × Ø28	6 × 6 × 40	0.63 {6.4}
10	GEK505M2ME3.7						Ø125 × Ø24 × Ø38		0.52 {5.3}
11	GEK505M2ME5.5	FC	Ø20 EA560H-20N	Ø20 × Ø36 × 8.5 × 4	6204ZZ	6204ZZ	Ø63 × Ø19 × Ø19	6 × 6 × 32	0.39 {4.0}
12	GEH655M2ME0.75						Ø74 × Ø19 × Ø24		0.87 {8.9}
13	GEH655M2ME1.5	FC	Ø20 EA560H-20N	Ø20 × Ø36 × 8.5 × 4	6304ZZ	6304ZZ	Ø100 × Ø19 × Ø24	6 × 6 × 32	0.81 {8.3}
14	GEI655M2ME2.2						Ø112 × Ø19 × Ø28		0.74 {7.6}
15	GEJ655M2ME3.7	CAC406(BC6)	Ø30 EA560H-30N	Ø30 × Ø46 × 8.5 × 4	6306ZZ	6306ZZ	Ø125 × Ø24 × Ø38	8 × 7 × 40	0.65 {6.6}
16	GEK655M2ME5.5						Ø140 × Ø24 × Ø42		0.52 {5.3}
17	GEK655M2ME7.5	SCS13	Ø30 EA560H-30N	Ø30 × Ø46 × 8.5 × 4	6306ZZ	6306ZZ	Ø140 × Ø24 × Ø42	8 × 7 × 40	0.42 {4.3}
18	GEL655M2ME11						0.22 {2.3}		
19	GEL655M2ME15								0.059 {0.6}
20	GEH805M2ME2.2	FC	Ø20 EA560H-20N	Ø20 × Ø36 × 8.5 × 4	6204ZZ	6204ZZ	Ø74 × Ø19 × Ø24	6 × 6 × 32	0.81 {8.3}
21	GEI805M2ME3.7						Ø112 × Ø24 × Ø28		0.74 {7.5}
22	GEJ805M2ME5.5	CAC406(BC6)	Ø30 EA560H-30N	Ø30 × Ø46 × 8.5 × 4	6306ZZ	6306ZZ	Ø125 × Ø24 × Ø38	8 × 7 × 40	0.66 {6.7}
23	GEJ805M2ME7.5						Ø140 × Ø24 × Ø42		0.58 {5.9}
24	GEK805M2ME11	SCS13	Ø35 EA560H-35N	Ø35 × Ø51 × 8.5 × 4	6307ZZ	6307ZZ	Ø140 × Ø32 × Ø42	10 × 8 × 50	0.45 {4.6}
25	GEK805M2ME15						Ø160 × Ø32 × Ø48		0.33 {3.4}
26	GEL805M2ME18	FC	Ø30 EA560H-30N	Ø30 × Ø46 × 8.5 × 4	6306ZZ	6306ZZ	Ø140 × Ø24 × Ø42	8 × 7 × 40	0.32 {3.3}
27	GEL805M2ME22						Ø125 × Ø24 × Ø38		0.13 {1.3}
28	GEI1005M2ME7.5	CAC406(BC6)	Ø35 EA560H-35N	Ø35 × Ø51 × 8.5 × 4	6307ZZ	6307ZZ	Ø125 × Ø24 × Ø38	10 × 8 × 50	0.69 {7.0}
29	GEJ1005M2ME11						Ø140 × Ø24 × Ø42		0.62 {6.3}
30	GEJ1005M2ME15	SCS13	Ø35 EA560H-35N	Ø35 × Ø51 × 8.5 × 4	6307ZZ	6307ZZ	Ø140 × Ø32 × Ø42	10 × 8 × 50	0.54 {5.5}
31	GEK1005M2ME18						Ø160 × Ø32 × Ø48		0.44 {4.5}
32	GEK1005M2ME22	CAC702(ALBC2)	Ø35 EA560H-35N	Ø35 × Ø51 × 8.5 × 4	6307ZZ	6307ZZ	Ø180 × Ø32 × Ø55	10 × 8 × 50	0.37 {3.8}
33	GEL1005M2ME30						0.22 {2.2}		
34	GEL1005M2ME37	SCS13	Ø35 EA560H-35N	Ø35 × Ø51 × 8.5 × 4	6307ZZ	6307ZZ	Ø180 × Ø32 × Ø55	10 × 8 × 50	0.098 {1.0}
35	GEL1005M2ME45						0		

PUMP DATA

No.	Model	Motor		Impeller Diameter (mm)	Coupling CLA	Shaft Diameter	
		Power (kW)	Frame (No.)			Pump (mm)	Motor (mm)
1	GEH-40×325M-2MN0.4	0.4	71M	G-104	AF-63	19	14
2	GEI405M2ME0.75	0.75	80M	G-125	AF-63	19	19
3	GEJ405M2ME1.5	1.5	90L	G-155	AF-74	19	24
4	GEJ405M2ME2.2	2.2	90L	G-175	AF-74	19	24
5	GEH-50×405M-2MN0.4	0.4	71M	G-96	AF-63	19	14
6	GEH505M2ME0.75	0.75	80M	G-113	AF-63	19	19
7	GEI505M2ME1.5	1.5	90L	G-135	100	19	24
8	GEJ505M2ME2.2	2.2	90L	G-156	100	19	24
9	GEJ505M2ME3.7	3.7	112M	G-165	112	19	28
10	GEK505M2ME3.7	3.7	112M	G-188	112	24	28
11	GEK505M2ME5.5	5.5	132S	G-211	125	24	38
12	GEH655M2ME0.75	0.75	80M	G-95	AF-63	19	19
13	GEH655M2ME1.5	1.5	90L	G-115	AF-74	19	24
14	GEI655M2ME2.2	2.2	90L	G-134	100	19	24
15	GEJ655M2ME3.7	3.7	112M	G-158	112	19	28
16	GEK655M2ME5.5	5.5	132S	G-185	125	24	38
17	GEK655M2ME7.5	7.5	132S	G-203	125	24	38
18	GEL655M2ME11	11	160M	G-238	140	24	42
19	GEL655M2ME15	15	160M	G-265	140	24	42
20	GEH805M2ME2.2	2.2	90L	G-115	AF-74	19	24
21	GEI805M2ME3.7	3.7	112M	G-137	112	24	28
22	GEJ805M2ME5.5	5.5	132S	G-153	125	24	38
23	GEJ805M2ME7.5	7.5	132S	G-172	125	24	38
24	GEK805M2ME11	11	160M	G-198	140	24	42
25	GEK805M2ME15	15	160M	G-218	140	24	42
26	GEL805M2ME18	18.5	160L	G-240	140	32	42
27	GEL805M2ME22	22	180M	G-254	160	32	48
28	GEI1005M2ME7.5	7.5	132S	G-152	125	24	38
29	GEJ1005M2ME11	11	160M	G-163	140	24	42
30	GEJ1005M2ME15	15	160M	G-179	140	24	42
31	GEK1005M2ME18	18.5	160L	G-203	140	32	42
32	GEK1005M2ME22	22	180M	G-214	160	32	48
33	GEL1005M2ME30	30	180L	G-244	180	32	55
34	GEL1005M2ME37	37	200LB	G-260	180	32	55
35	GEL1005M2ME45	45	200LB	G-276	180	32	55

SECTION VIEW - MECHANICAL SEAL

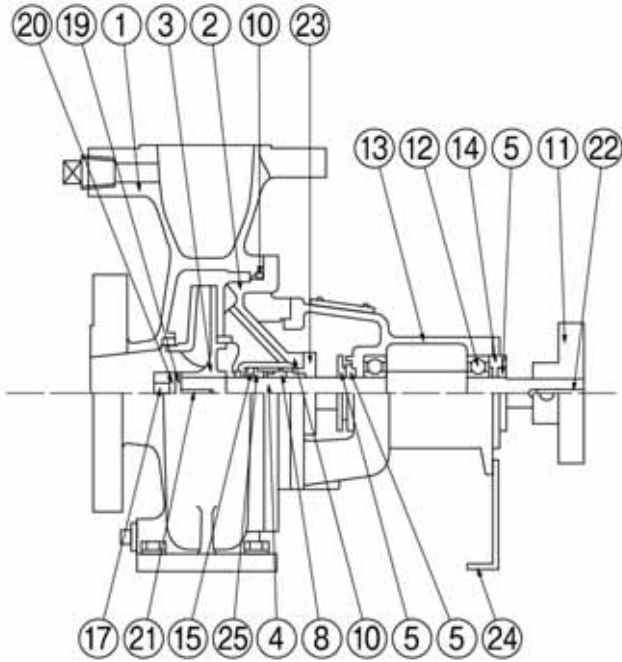

No.	Parts name	Material	Q'ty
1	Casing	Cast iron	1
2	Casing cover	Cast iron	1
3	Impeller	Cast iron, Bronze or SCS13	1
4	Shaft	SUS403	1
5	Deflector	Rubber	3
8	Mechanical seal	Sic x Carbon	1
10	O ring	Rubber	1
11	Shaft coupling	Cast iron	1
12	Bearing	Sealed bearing	1
13	Bearing box	Cast iron	1
14	Bearing cover	Cast iron	1
15	Screw	SUS304	1
17	Nut	SUS304	1
19	Plane washer	SUS304	1
20	Spring washer	SUS304	1
21	Key	SUS304	1
22	Key	S45C	1
23	Mechanical seal cover	Bronze	1
24	Supporter	SPCC	1
25	Stopper ring	SUS316	1

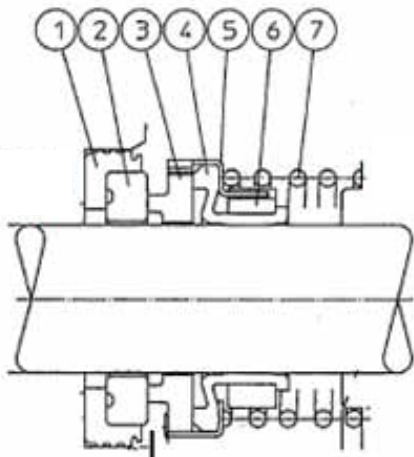

No.	Parts name	Material	Q'ty
1	Cup gasket	FKM	1
2	Mating ring	SIC	1
3	Seal ring	Carbon	1
4	Bellows	FKM	1
5	Case	SUS304	1
6	Drive ring	SUS304	1
7	Coil spring	SUS304	1

SECTION VIEW - GLAND PACKING SEAL

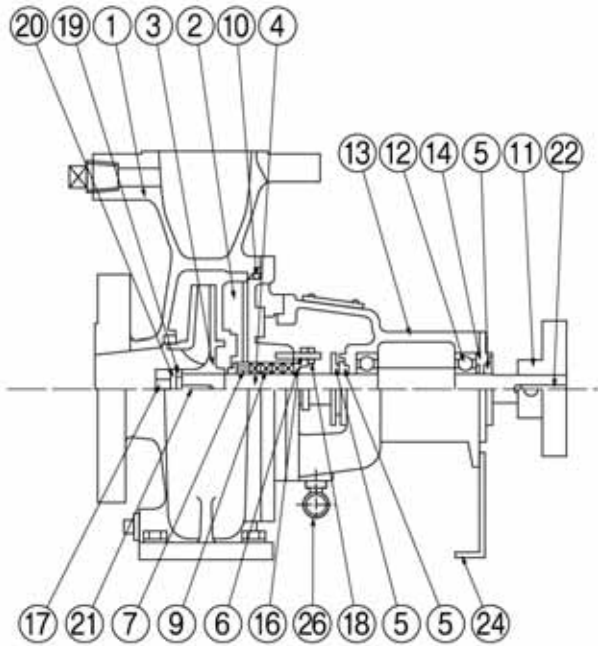

No.	Parts name	Material	Q'ty
1	Casing	Cast iron	1
2	Casing cover	Cast iron	1
3	Impeller	Cast iron, Bronze or SCS13	1
4	Shaft	SUS403	1
5	Deflector	Rubber	3
6	Packing gland	Bronze	1
7	Lantern ring	Bronze	1
9	Gland packing	Non asbestos	4-5
10	O ring	Rubber	1
11	Shaft coupling	Cast iron	1
12	Bearing	Sealed bearing	1
13	Bearing box	Cast iron	1
14	Bearing cover	Cast iron	1
15	Screw	SUS304	1
16	Double nut stud bolt	C3604	2
18	Plane washer	C3604	2
19	Plane washer	SUS304	1
20	Spring washer	SUS304	1
21	Key	SUS304	1
22	Key	S45C	1
24	Supporter	SPCC	1
25	Stopper ring	SUS316	1
26	Elbow	FCMB28	1

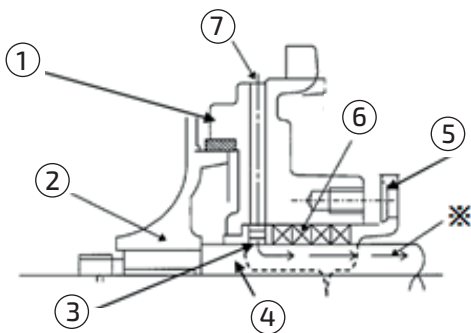

Detail of stuffing box

No.	Parts name	Material	Q'ty
1	Casing cover	Cast iron	1
2	Impeller	Cast iron	1
3	Lantern ring	Bronze	1
4	Shaft	SUS403	1
5	Packing grand	Bronze	4-5
6	Grand packing	Non asbestos	1
7	Filler	-	1

DRAWING DIMENSION – BARE PUMP

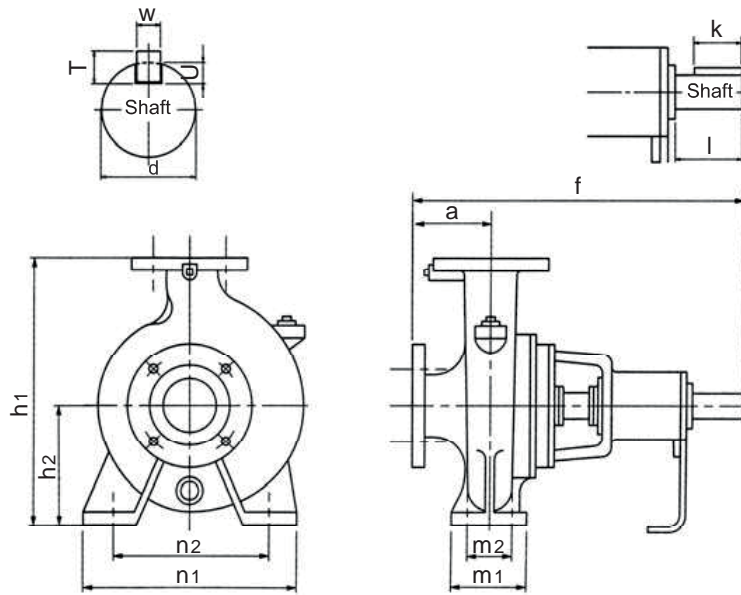

Suction d ₁	Discharge d ₂	Model	Motor (kW)	Pump Dimension								Shaft			Coupling Key		
				a	f	h ₁	h ₂	n ₁	n ₂	m ₁	m ₂	d	l	u	w	t	k
40	32	GEH-40×325M-2MN0.4	0.4	65	265	225	100	155	125	80	56	19	28	3.5	6	6	20
		GEI405M2ME0.75	0.75	65	265	252	112	180	140	80	56	19	28	3.5	6	6	20
		GEJ405M2ME1.5	1.5	80	360	292	132	240	190	100	70	19	40	3.5	6	6	32
		GEJ405M2ME2.2	2.2	80	360	292	132	240	190	100	70	19	40	3.5	6	6	32
50	40	GEH-50×405M-2MN0.4	0.4	65	265	252	112	180	140	80	56	19	28	3.5	6	6	20
		GEH505M2ME0.75	0.75	65	265	252	112	180	140	80	56	19	28	3.5	6	6	20
		GEI505M2ME1.5	1.5	80	440	252	112	190	140	100	70	19	40	3.5	6	6	32
		GEJ505M2ME2.2	2.2	80	440	292	132	240	192	100	70	19	40	3.5	6	6	32
		GEJ505M2ME3.7	3.7	80	440	292	132	240	192	100	70	19	40	3.5	6	6	32
		GEK505M2ME3.7	3.7	80	440	340	160	240	190	100	70	24	50	4	8	7	40
		GEK505M2ME5.5	5.5	80	440	340	160	240	190	100	70	24	50	4	8	7	40
65	50	GEH655M2ME0.75	0.75	80	360	252	112	190	140	100	70	19	40	3.5	6	6	32
		GEH655M2ME1.5	1.5	80	360	252	112	190	140	100	70	19	40	3.5	6	6	32
		GEI655M2ME2.2	2.2	80	440	252	112	210	160	100	70	19	40	3.5	6	6	32
		GEJ655M2ME3.7	3.7	80	440	292	132	240	190	100	70	19	40	3.5	6	6	32
		GEK655M2ME5.5	5.5	100	460	340	160	265	212	100	70	24	50	4	8	7	40
		GEK655M2ME7.5	7.5	100	460	340	160	265	212	100	70	24	50	4	8	7	40
		GEL655M2ME11	11	100	460	405	180	320	250	125	95	24	50	4	8	7	40
		GEL655M2ME15	15	100	460	405	180	320	250	125	95	24	50	4	8	7	40

DRAWING DIMENSION – BARE PUMP

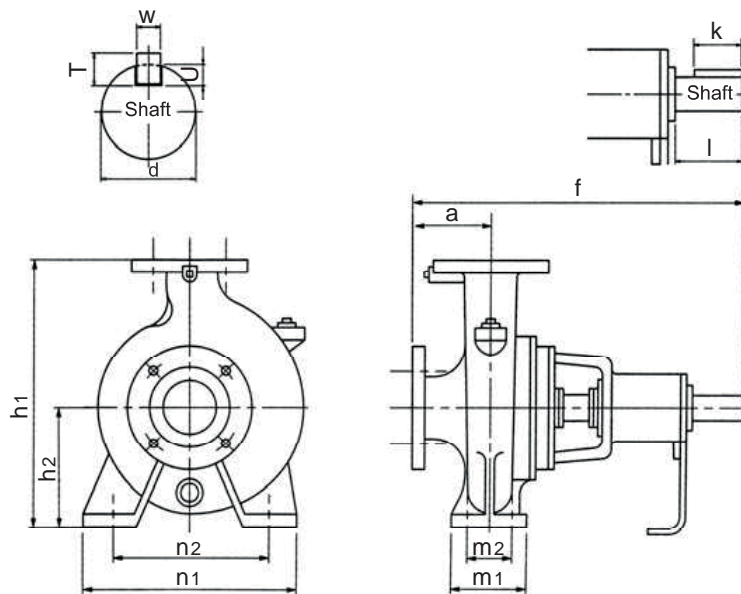

Suction d ₁	Discharge d ₂	Model	Motor (kW)	Pump Dimension								Shaft			Coupling Key		
				a	f	h ₁	h ₂	n ₁	n ₂	m ₁	m ₂	d	l	u	w	t	k
80	65	GEH805M2ME2.2	2.2	100	380	292	132	240	190	100	70	19	40	3.5	6	6	32
		GEI805M2ME3.7	3.7	100	460	292	132	240	190	100	70	24	50	4	8	7	40
		GEJ805M2ME5.5	5.5	100	460	340	160	265	212	100	70	24	50	4	8	7	40
		GEJ805M2ME7.5	7.5	100	460	340	160	265	212	100	70	24	50	4	8	7	40
		GEK805M2ME11	11	100	460	360	160	265	212	100	70	24	50	4	8	7	40
		GEK805M2ME15	15	100	460	360	160	265	212	100	70	24	50	4	10	7	40
		GEL805M2ME18	18	100	460	405	180	320	250	125	95	32	80	5	10	8	50
		GEL805M2ME22	22	100	460	405	180	320	250	125	95	32	80	5	8	8	50
100	80	GEI1005M2ME7.5	7.5	100	460	340	160	280	212	125	95	24	50	4	8	7	40
		GEJ1005M2ME11	11	100	460	360	160	280	212	125	95	24	50	4	8	7	40
		GEJ1005M2ME15	15	100	460	360	160	280	212	125	95	24	50	4	8	7	40
		GEK1005M2ME18	18	100	460	405	180	320	250	125	95	32	80	5	10	8	50
		GEK1005M2ME22	22	100	460	405	180	320	250	125	95	32	80	5	10	8	50
		GEL1005M2ME30	30	100	570	450	200	360	280	160	120	32	80	5	10	8	50
		GEL1005M2ME37	37	100	570	450	200	360	280	160	120	32	80	5	10	8	50
		GEL1005M2ME45	45	100	570	450	200	360	280	160	120	32	80	5	10	8	50

DRAWING DIMENSION - COMPLETE SET

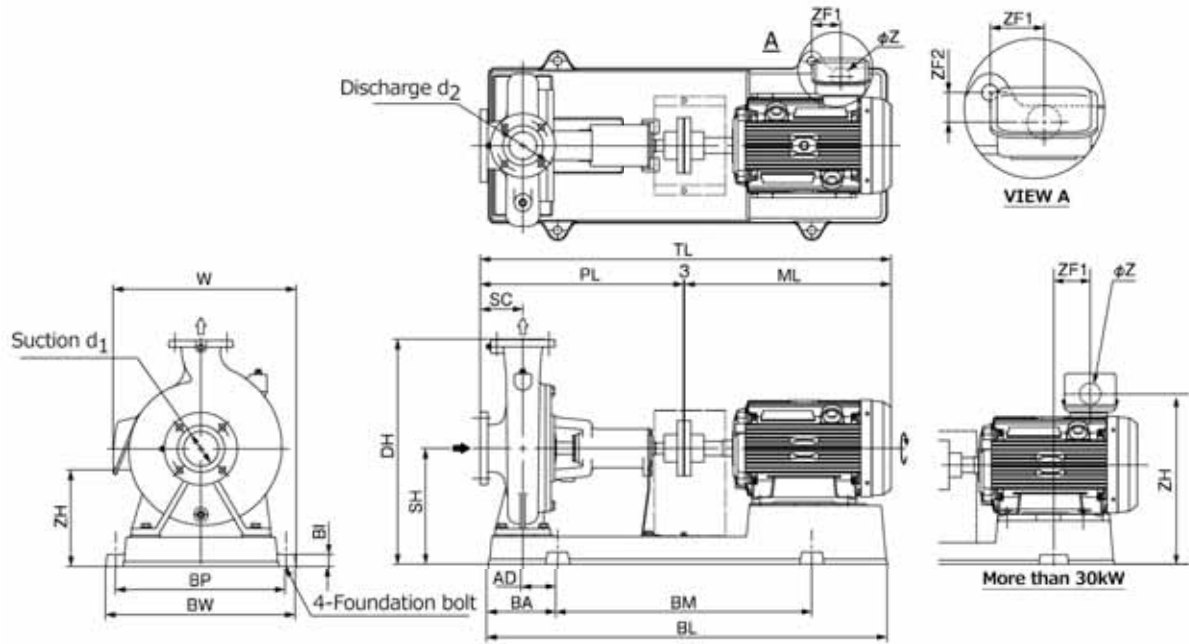

(REFERENCE JAPANESE MOTOR BRAND)

Suction d ₁	Discharge d ₂	Model	Motor kW	Pump		Baseplate					
				SC	PL	BI	BL	BA	BM	BP	BW
40	32	GEH-40×325M-2MN0.4	0.4	65	265	20	467	82	300	200	236
		GEI405M2ME0.75	0.75	65	265	20	468	82	300	230	266
		GEJ405M2ME1.5	1.5	80	360	25	648	112	420	290	336
		GEJ405M2ME2.2	2.2	80	360	25	648	112	420	290	336
50	40	GEH-50×405M-2MN0.4	0.4	65	265	20	468	82	300	230	266
		GEH505M2ME0.75	0.75	65	265	20	468	82	300	230	266
		GEI505M2ME1.5	1.5	80	440	25	726	127	480	290	336
		GEJ505M2ME2.2	2.2	80	440	25	722	120	480	290	33
		GEJ505M2ME3.7	3.7	80	440	25	818	138	540	320	366
		GEK505M2ME3.7	3.7	80	440	25	821	138	540	320	366
		GEK505M2ME5.5	5.5	80	440	25	819	138	540	350	396
65	50	GEH655M2ME0.75	0.75	80	360	20	577	102	370	230	266
		GEH655M2ME1.5	1.5	80	360	20	646	112	420	230	266
		GEI655M2ME2.2	2.2	80	440	25	726	127	480	290	336
		GEJ655M2ME3.7	3.7	80	440	25	818	138	540	320	366
		GEK655M2ME5.5	5.5	100	460	25	819	138	540	350	396
		GEK655M2ME7.5	7.5	100	460	25	819	138	540	350	396
		GEL655M2ME11	11	100	460	35	918	158	600	400	458
		GEL655M2ME15	15	100	460	35	918	158	600	400	458

Continue to the next page

DRAWING DIMENSION - COMPLETE SET

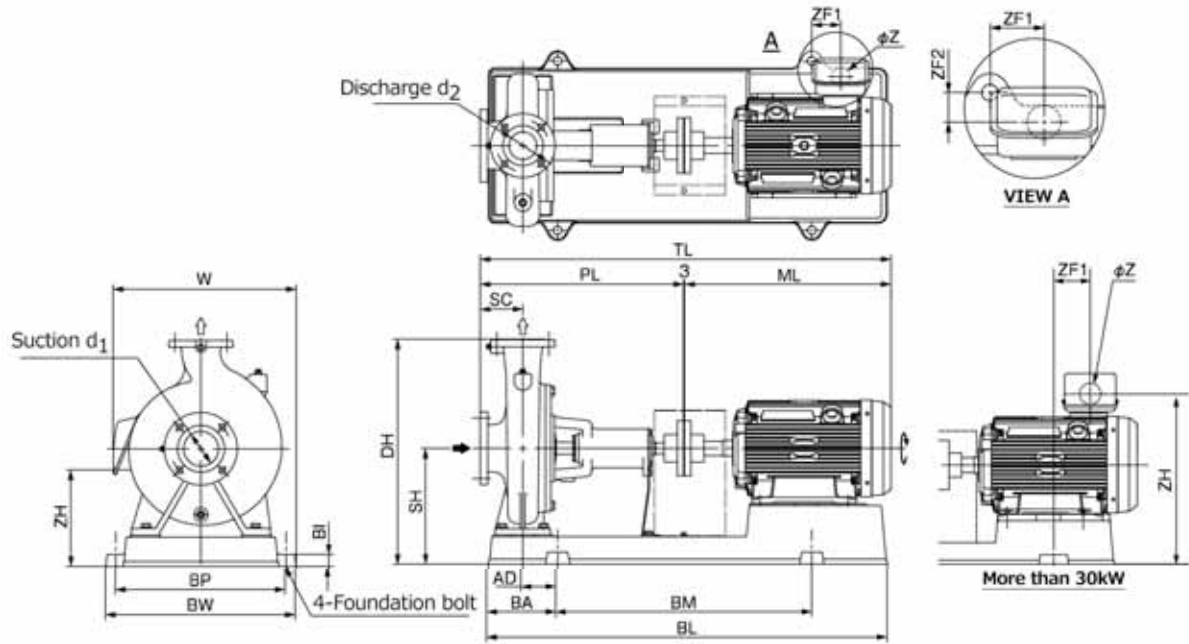

(REFERENCE JAPANESE MOTOR BRAND)

Suction d_1	Discharge d_2	Model	Motor (kW)	Combination										Weight (kg)
				DH	SH	TL	AD	W	ML	ZF1	ZF2	ZH	Z	
40	32	GEH-40×325M-2MN0.4	0.4	280	155	506	35	-	238	-29	29	151	12	31
		GEI405M2ME0.75	0.75	317	177	530	35	278	262	48	-3	160	27	40
		GEJ405M2ME1.5	1.5	347	187	675	50	-	312	35	13	174	27	55
		GEJ405M2ME2.2	2.2	347	187	675	50	-	312	35	13	174	27	57
50	40	GEH-50×405M-2MN0.4	0.4	307	167	506	35	-	238	-43	44	163	12	33
		GEH505M2ME0.75	0.75	317	177	530	35	278	262	48	-3	160	27	40
		GEI505M2ME1.5	1.5	307	167	755	60	-	312	45	13	154	27	61
		GEJ505M2ME2.2	2.2	347	187	755	55	-	312	50	13	174	27	64
		GEJ505M2ME3.7	3.7	357	197	830	70	-	381	22	8	190	27	85
		GEK505M2ME3.7	3.7	405	225	833	70	-	381	22	8	218	27	98
		GEK505M2ME5.5	5.5	405	225	894	70	-	451	67	2	215	27	112
65	50	GEH655M2ME0.75	0.75	307	167	625	35	278	262	58	-3	150	27	46
		GEH655M2ME1.5	1.5	307	167	675	45	291	312	40	-17	154	27	51
		GEI655M2ME2.2	2.2	307	167	755	60	-	312	45	13	154	27	64
		GEJ655M2ME3.7	3.7	357	197	830	70	-	381	22	8	190	27	88
		GEK655M2ME5.5	5.5	405	225	914	70	-	451	67	2	215	27	117
		GEK655M2ME7.5	7.5	405	225	914	70	-	451	67	2	215	27	123
		GEL655M2ME11	11	470	245	1038	75	496	575	116	-23	227	56	169
		GEL655M2ME15	15	470	245	1038	75	496	575	116	-23	227	56	179

Continue from the previous page

DRAWING DIMENSION - COMPLETE SET

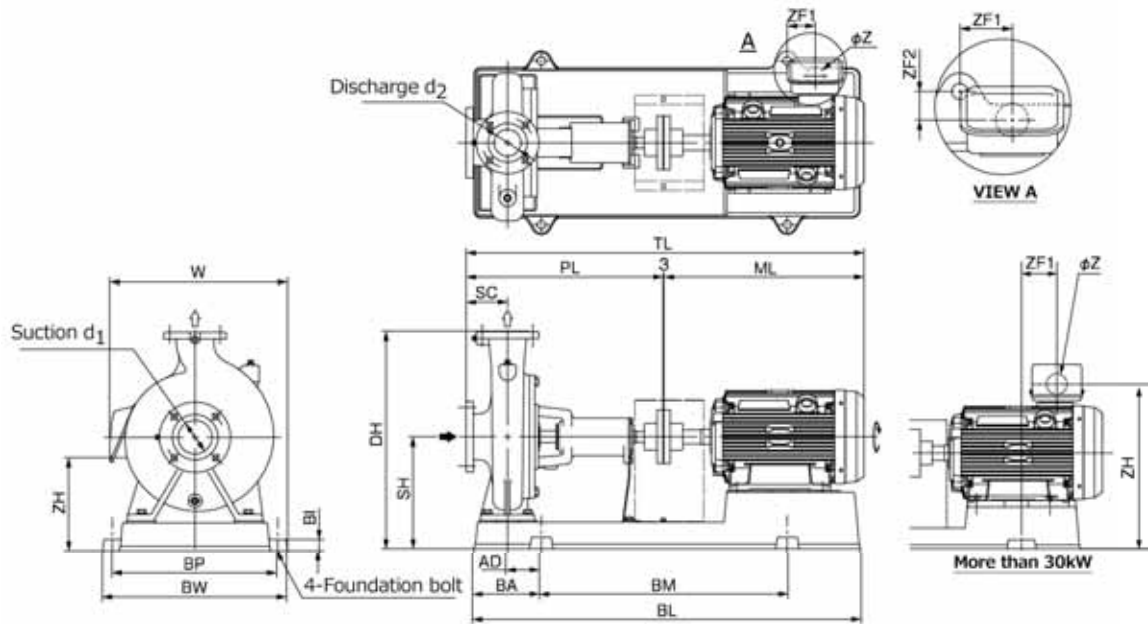

Suction d ₁	Discharge d ₂	Model	Motor (kW)	Pump			Baseplate							
				SC	PL	BI	BL	BA	BM	BP	BW			
80	65	GEH805M2ME2.2	2.2	100	380	25	648	112	420	290	336			
		GEI805M2ME3.7	3.7	100	460	25	818	138	540	320	366			
		GEJ805M2ME5.5	5.5	100	460	25	819	138	540	350	396			
		GEK805M2ME7.5	7.5	100	460	25	819	138	540	350	396			
		GEK805M2ME11	11	100	460	35	916	158	600	400	458			
		GEK805M2ME15	15	100	460	35	916	158	600	400	458			
		GEL805M2ME18	18	100	460	35	1018	178	660	400	458			
		GEL805M2ME22	22	100	460	35	1016	178	660	440	498			
100	80	GEI1005M2ME7.5	7.5	100	460	25	819	138	540	350	396			
		GEJ1005M2ME11	11	100	460	35	916	158	600	400	458			
		GEJ1005M2ME15	15	100	460	35	916	158	600	400	458			
		GEK1005M2ME18	18	100	460	35	1018	178	660	400	458			
		GEK1005M2ME22	22	100	460	35	1016	178	660	440	498			
		GEL1005M2ME30	30	100	570	35	1140	199	740	440	498			
		GEL1005M2ME37	37	100	570	35	1268	214	840	490	548			
		GEL1005M2ME45	45	100	570	35	1268	214	840	490	548			
Suction d ₁	Discharge d ₂	Model	Motor (kW)	Combination									Weight (kg)	
80	65	GEH805M2ME2.2	2.2	347	187	695	50	-	312	35	13	174	27	60
		GEI805M2ME3.7	3.7	357	197	850	70	-	381	22	8	190	27	96
		GEJ805M2ME5.5	5.5	405	225	914	70	-	451	67	2	215	27	116
		GEK805M2ME7.5	7.5	405	225	914	70	-	451	67	2	215	27	122
		GEK805M2ME11	11	425	225	1038	90	496	575	101	-23	207	56	160
		GEK805M2ME15	15	425	225	1038	90	496	575	101	-23	207	56	170
		GEL805M2ME18	18	470	245	1082	95	496	619	80	-23	227	56	219
		GEL805M2ME22	22	470	245	1107	95	541	644	87	-21	226	56	249
100	80	GEI1005M2ME7.5	7.5	405	225	914	60	-	451	77	-2	215	27	128
		GEJ1005M2ME11	11	425	225	1038	75	496	575	116	23	207	56	163
		GEJ1005M2ME15	15	425	225	1038	75	496	575	116	23	207	56	173
		GEK1005M2ME18	18	470	245	1082	95	496	619	80	23	227	56	209
		GEK1005M2ME22	22	470	245	1107	95	538	644	87	21	233	56	244
		GEL1005M2ME30	30	535	285	1293	100	-	720	188	145	534	56	348
		GEL1005M2ME37	37	535	285	1324	115	-	751	59	113	583	90	399
		GEL1005M2ME45	45	535	285	1324	115	-	751	59	113	583	90	413

INDIVIDUAL EXPECTED PERFORMANCE CURVE

MODEL : GEH-40x325M(G)-2MN0.4

■ PERFORMANCE CURVES

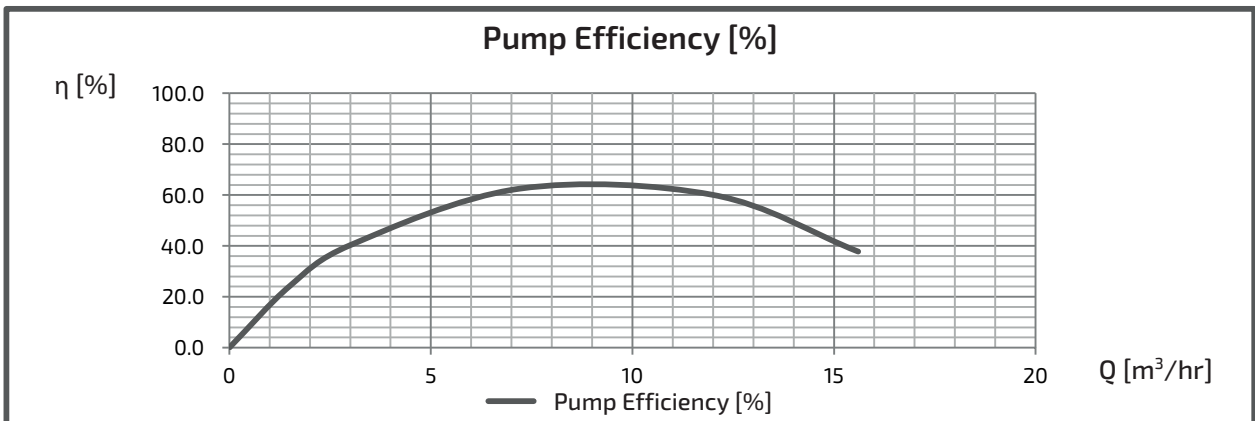
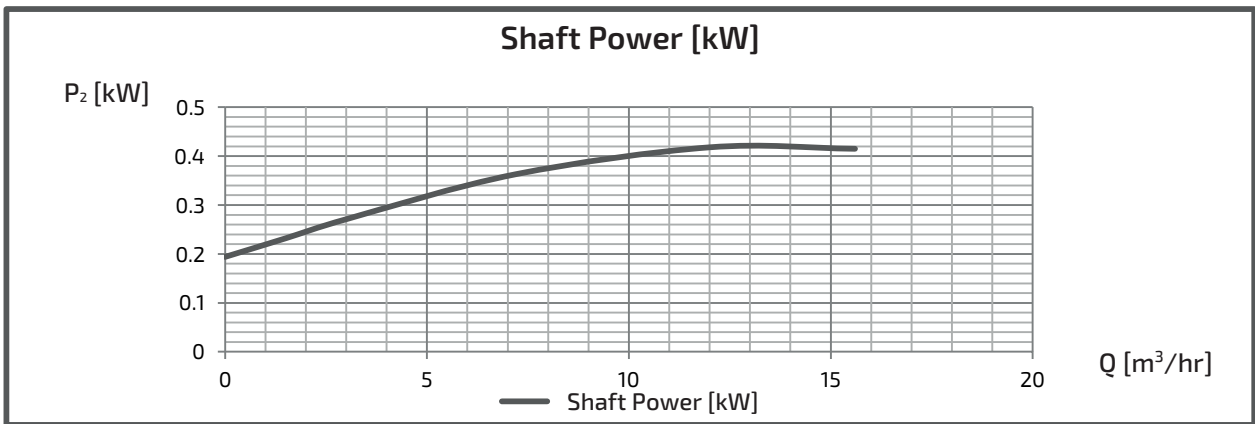
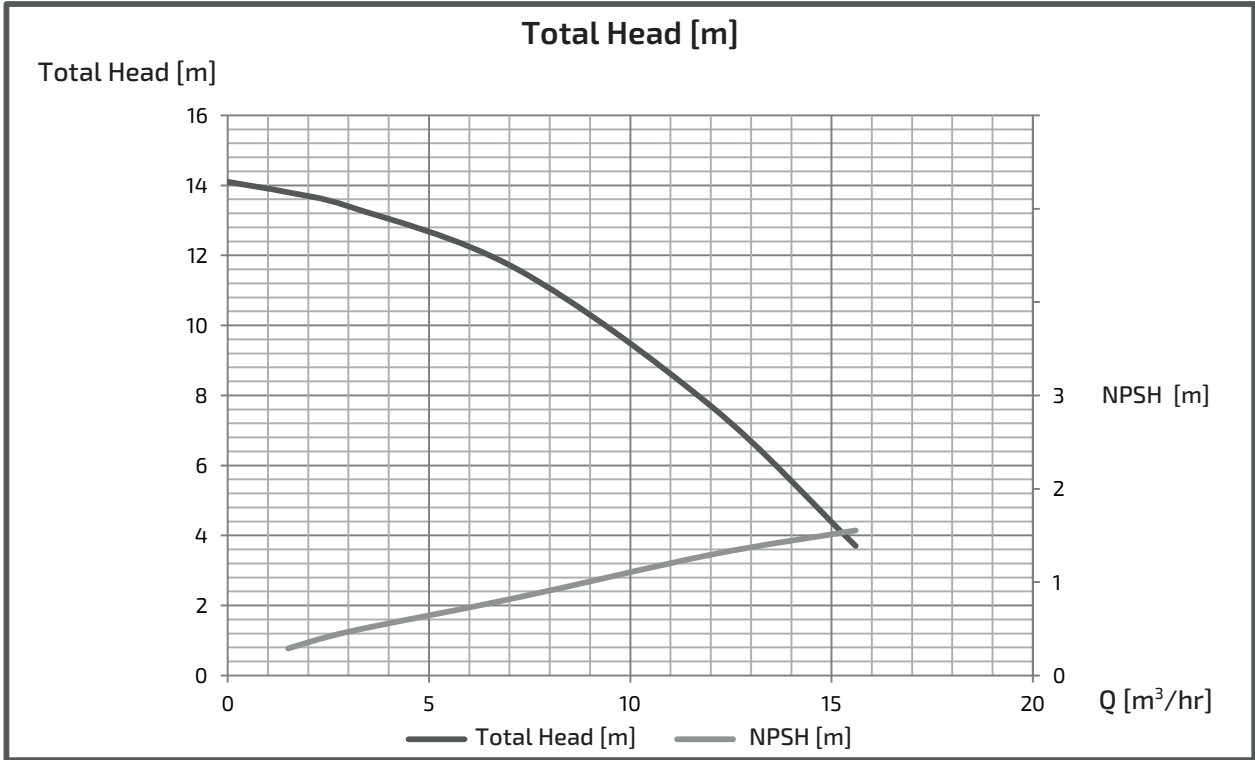

INDIVIDUAL EXPECTED PERFORMANCE CURVE

MODEL : GEI405M(G)2ME0.75

■ PERFORMANCE CURVES

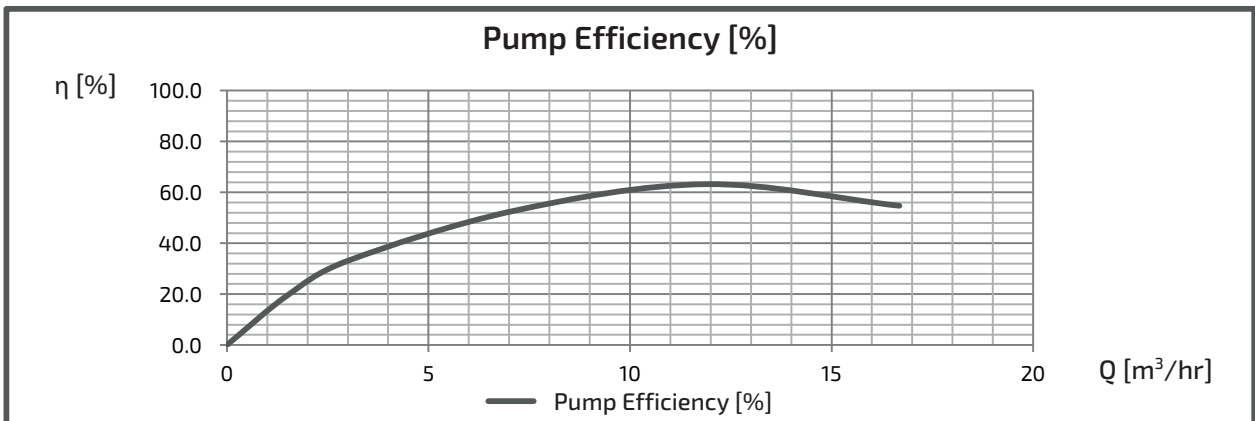
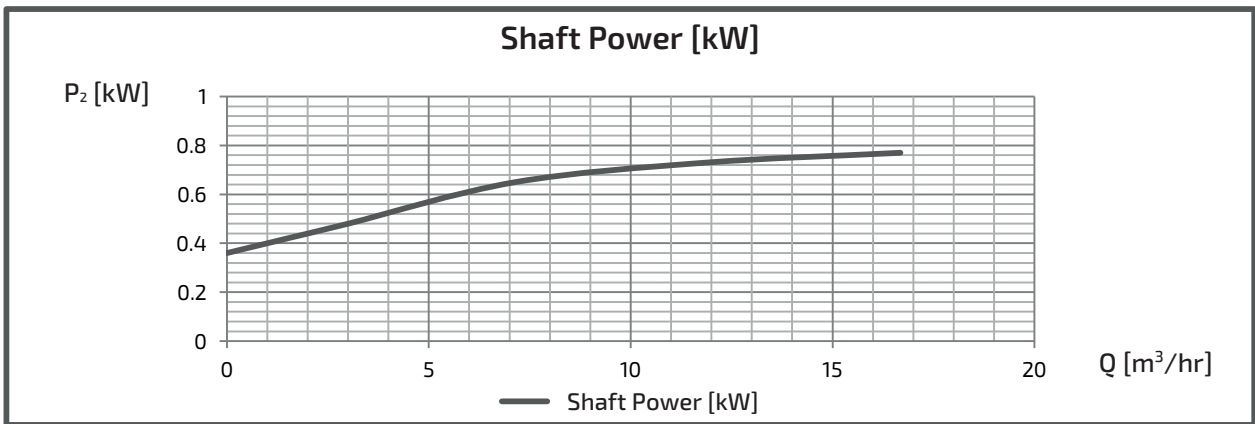
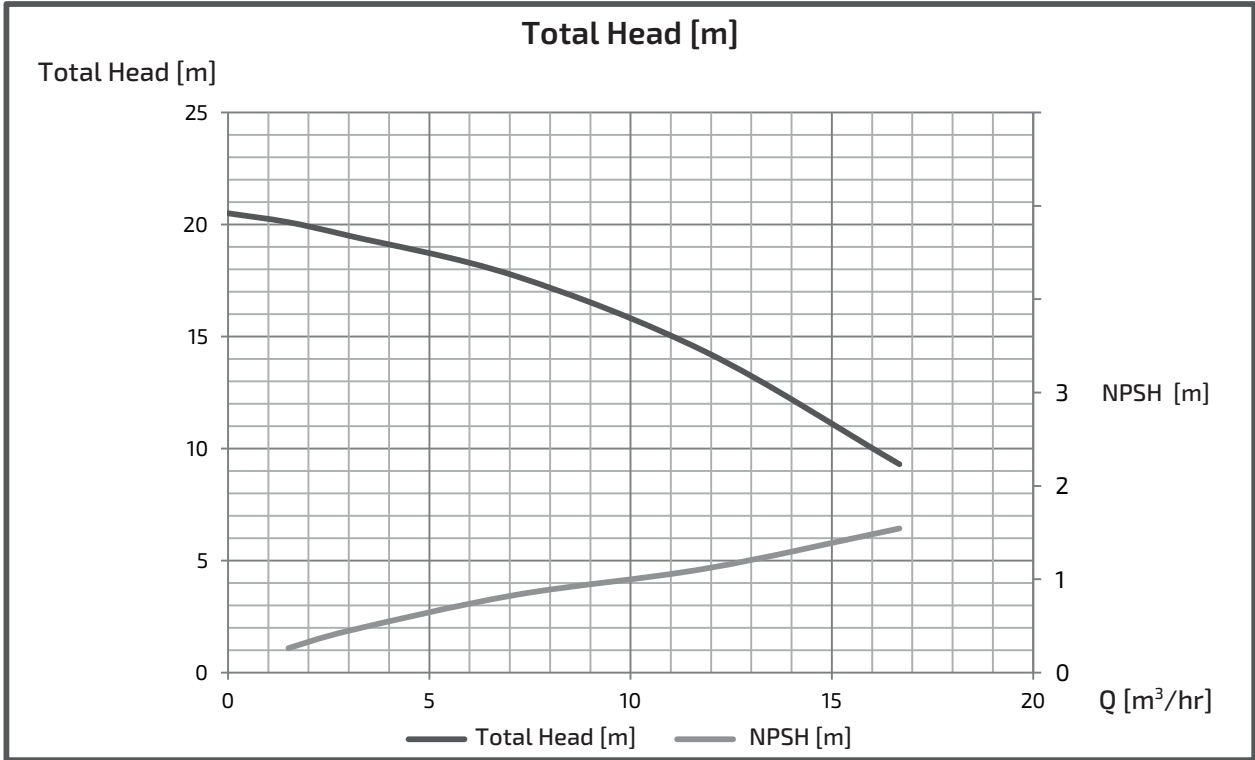

INDIVIDUAL EXPECTED PERFORMANCE CURVE

MODEL : GEJ405M(G)2ME1.5

■ PERFORMANCE CURVES

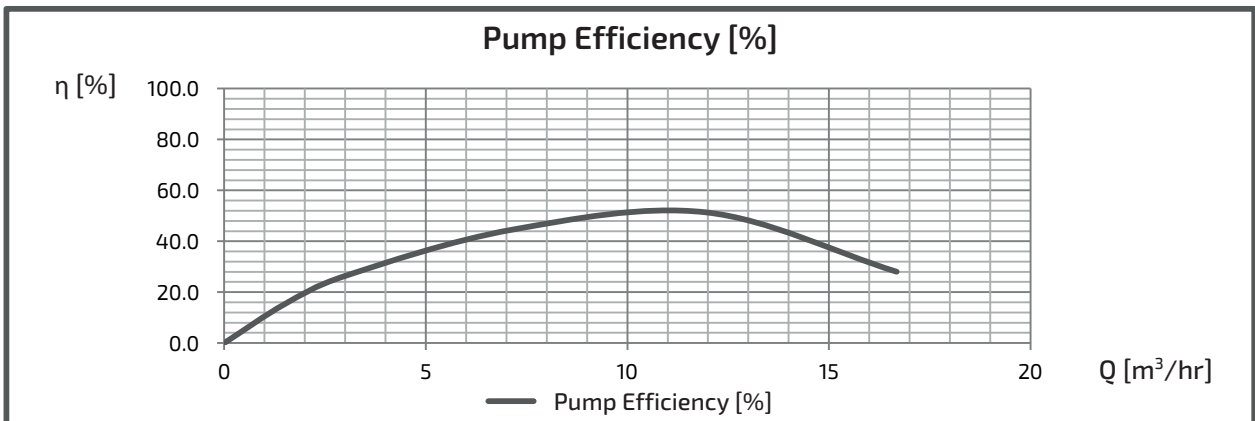
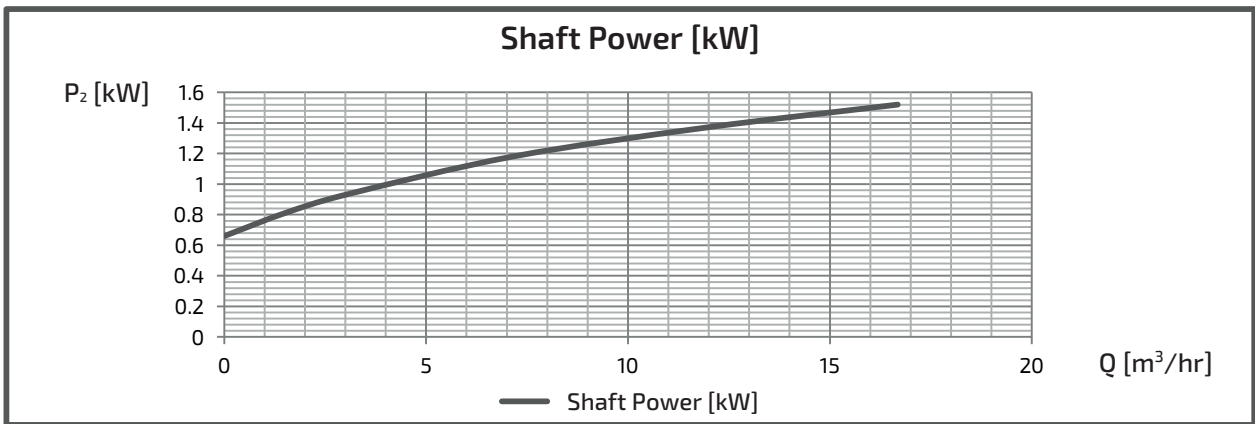
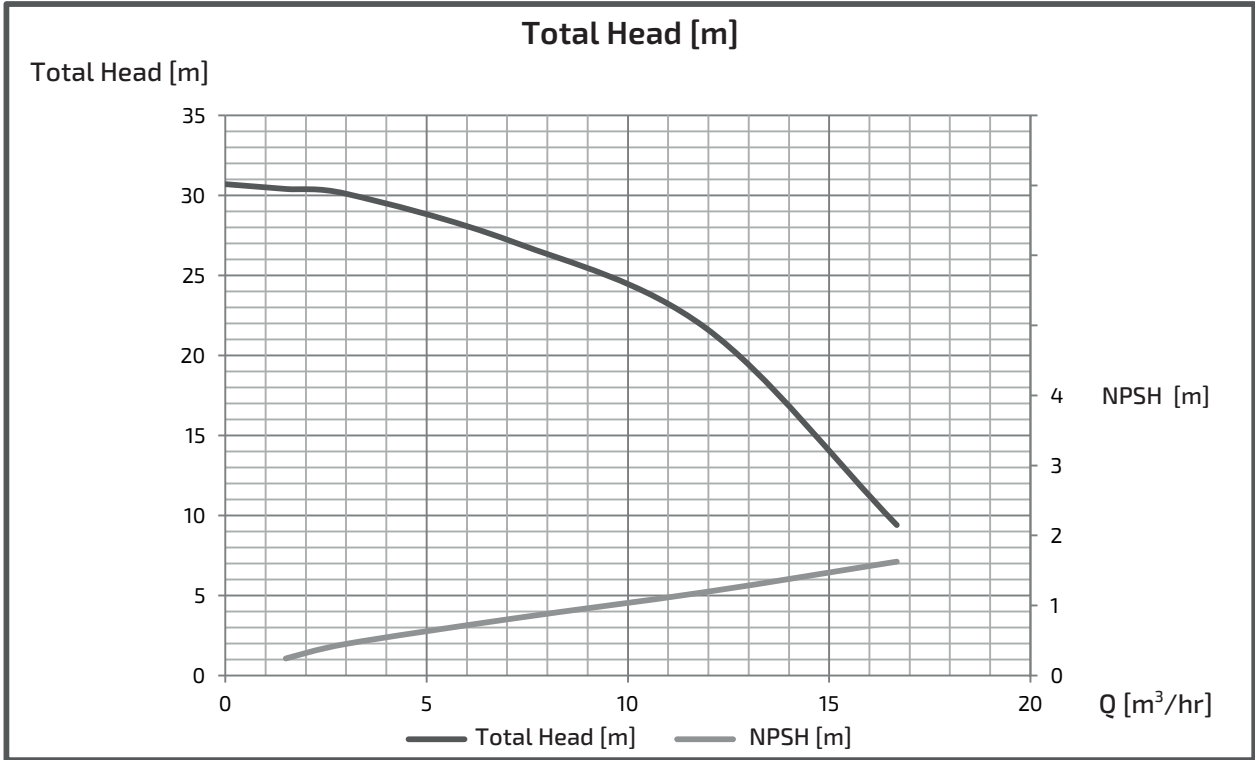

INDIVIDUAL EXPECTED PERFORMANCE CURVE

MODEL : GEJ405M(G)2ME2.2

■ PERFORMANCE CURVES

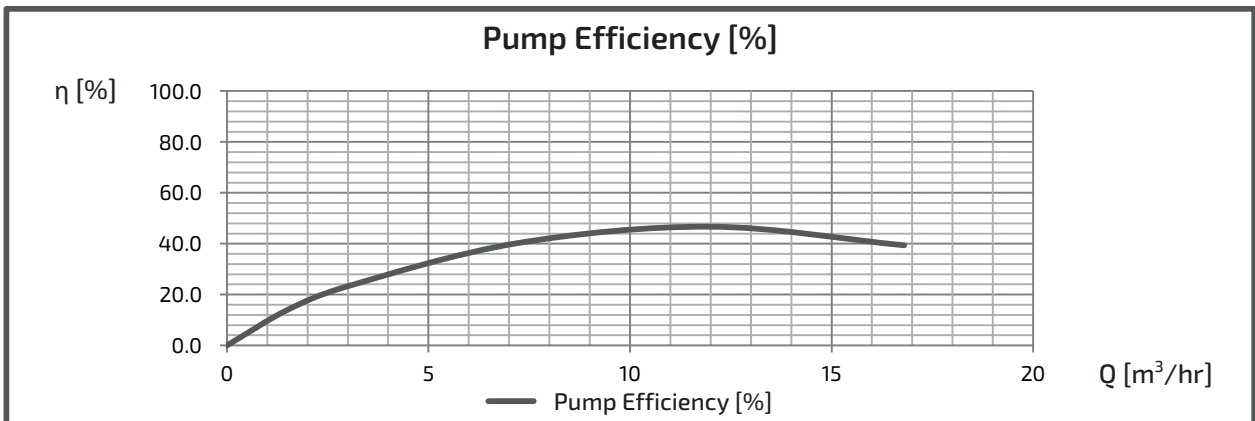
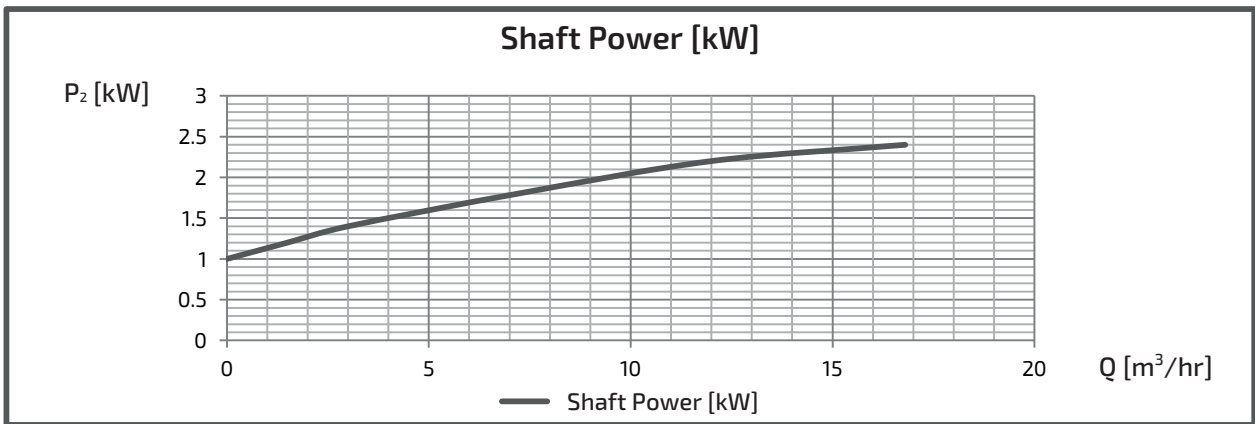
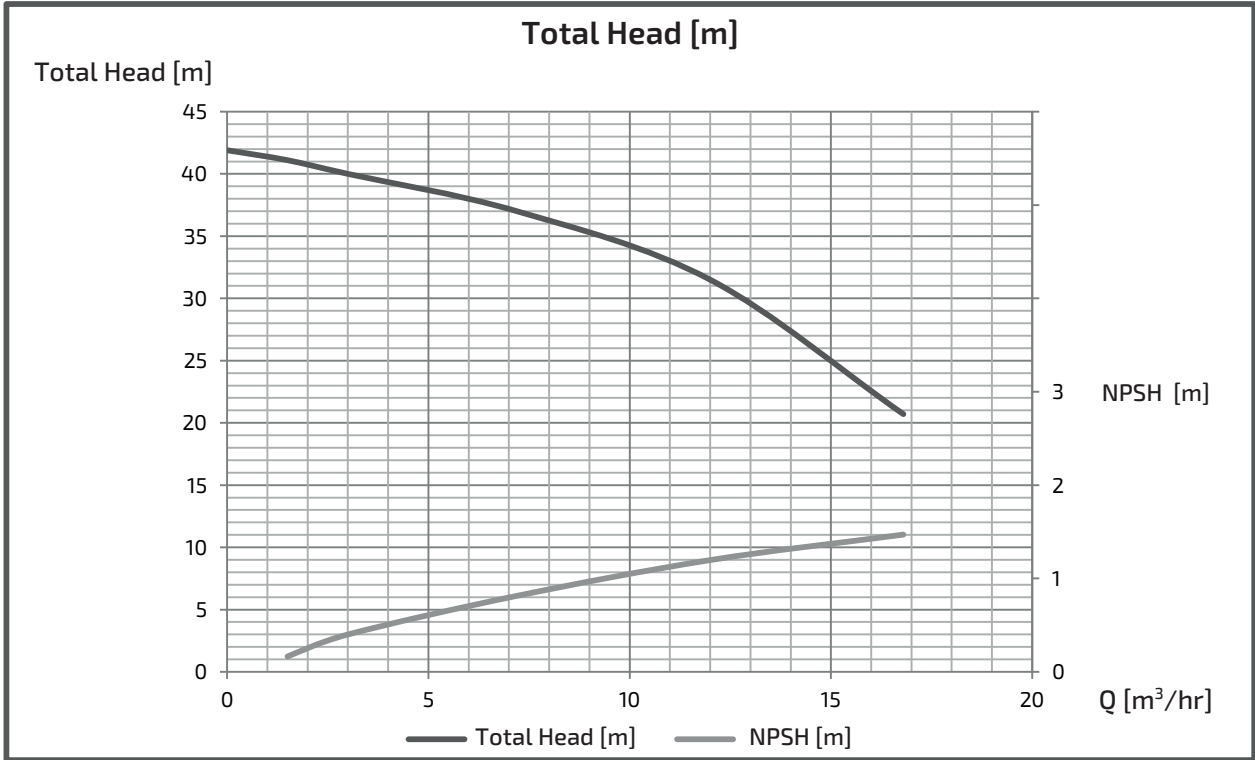

INDIVIDUAL EXPECTED PERFORMANCE CURVE

MODEL : GEH-50x405M(G)-2MN0.4

■ PERFORMANCE CURVES

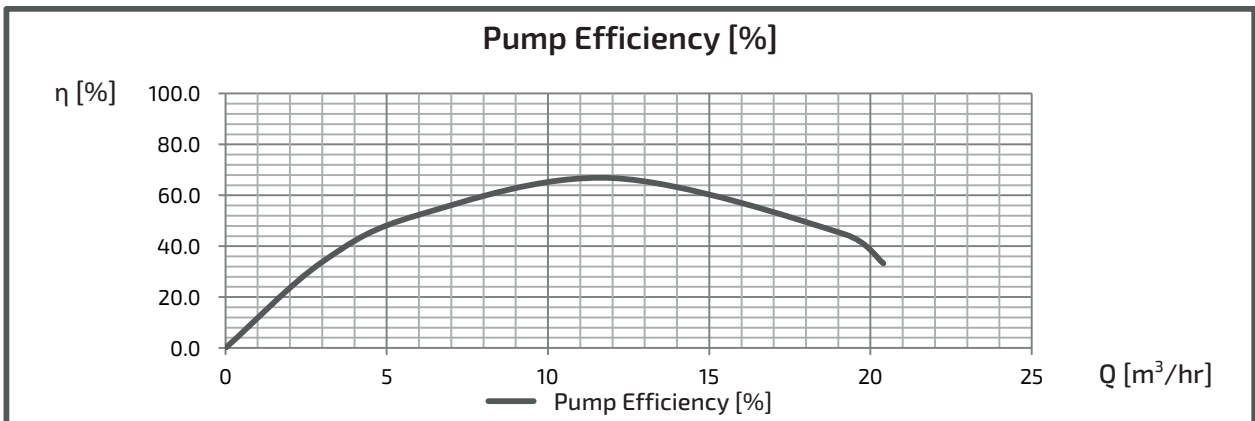
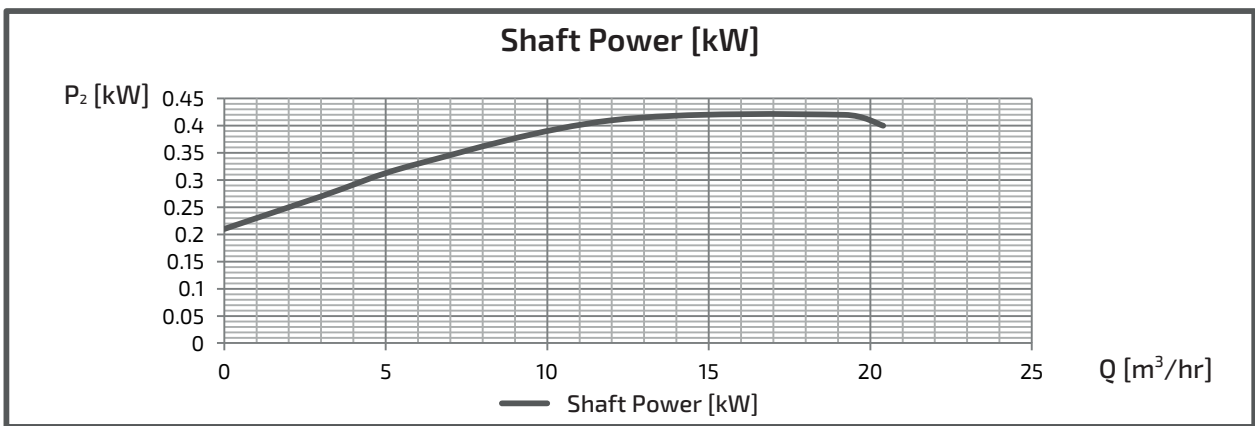
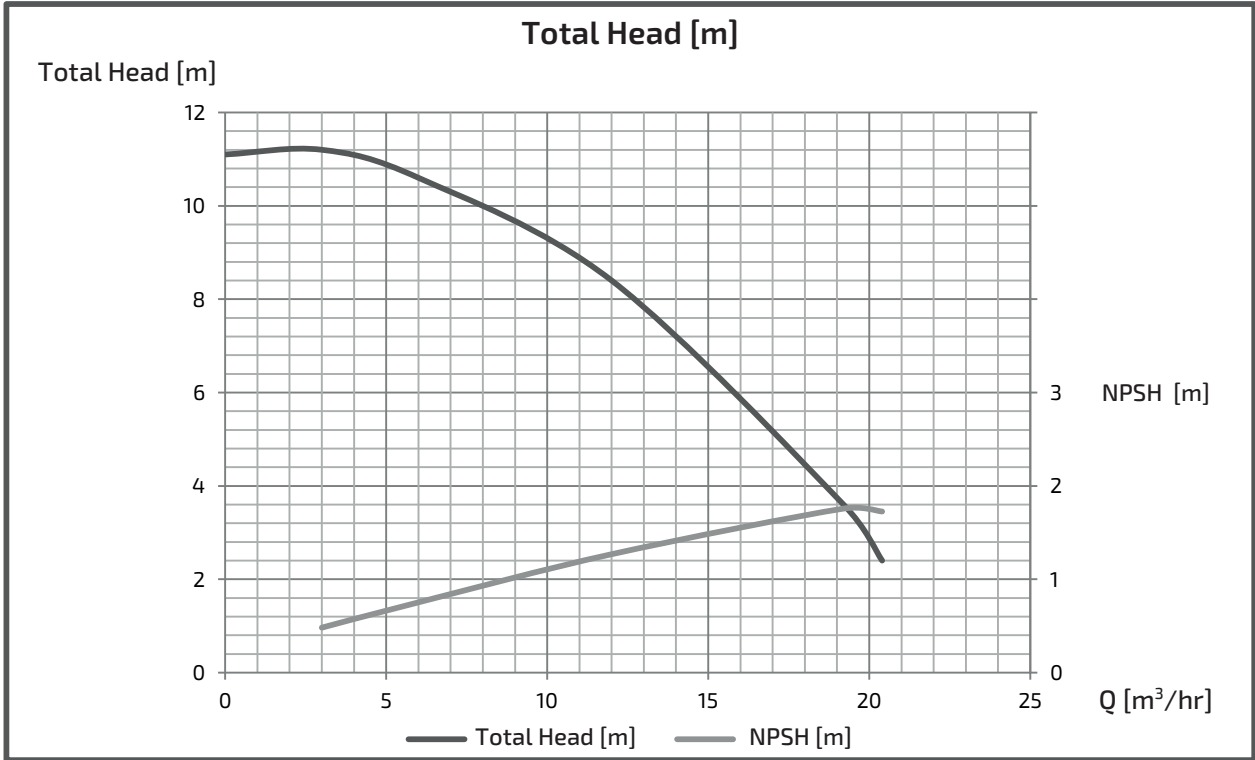

INDIVIDUAL EXPECTED PERFORMANCE CURVE

MODEL : GEH505M(G)2ME0.75

■ PERFORMANCE CURVES

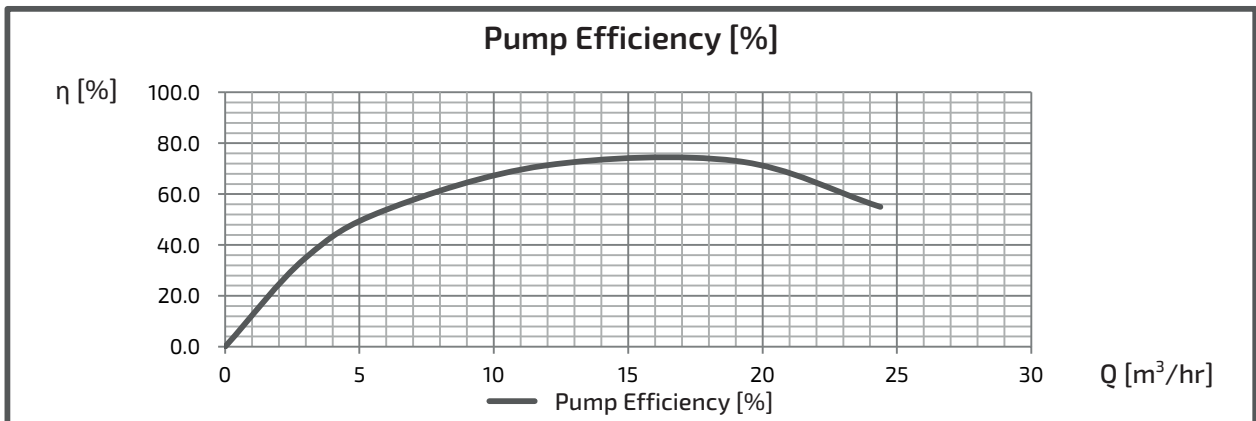
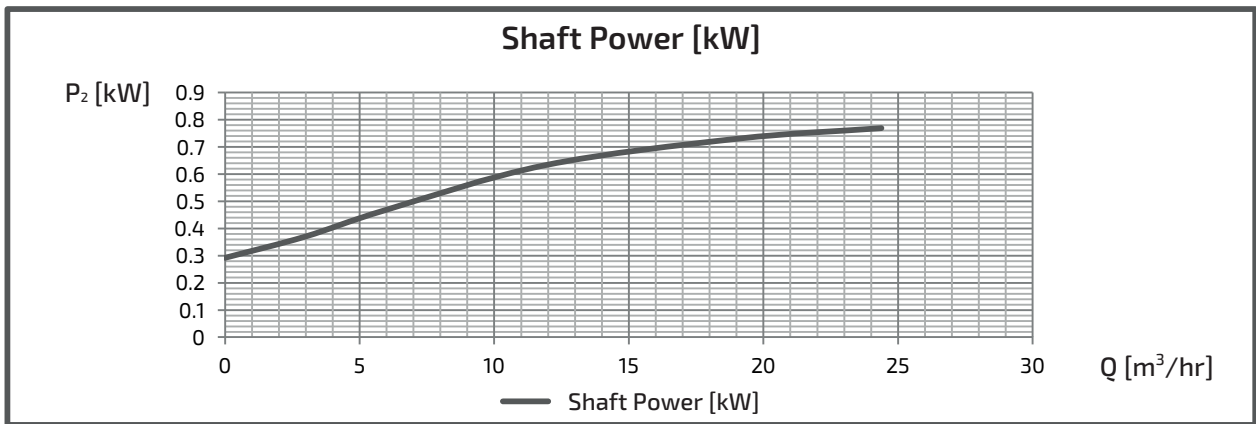
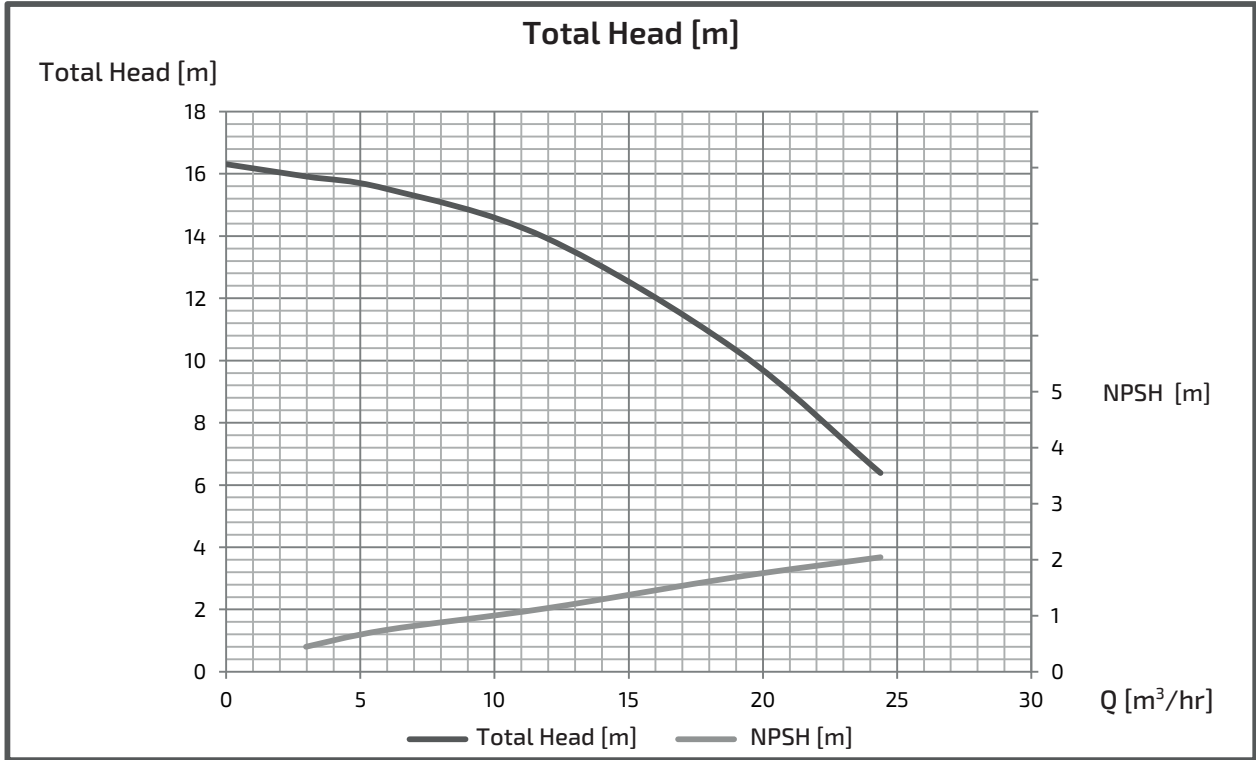

INDIVIDUAL EXPECTED PERFORMANCE CURVE

MODEL : GEI505M(G)2ME1.5

■ PERFORMANCE CURVES

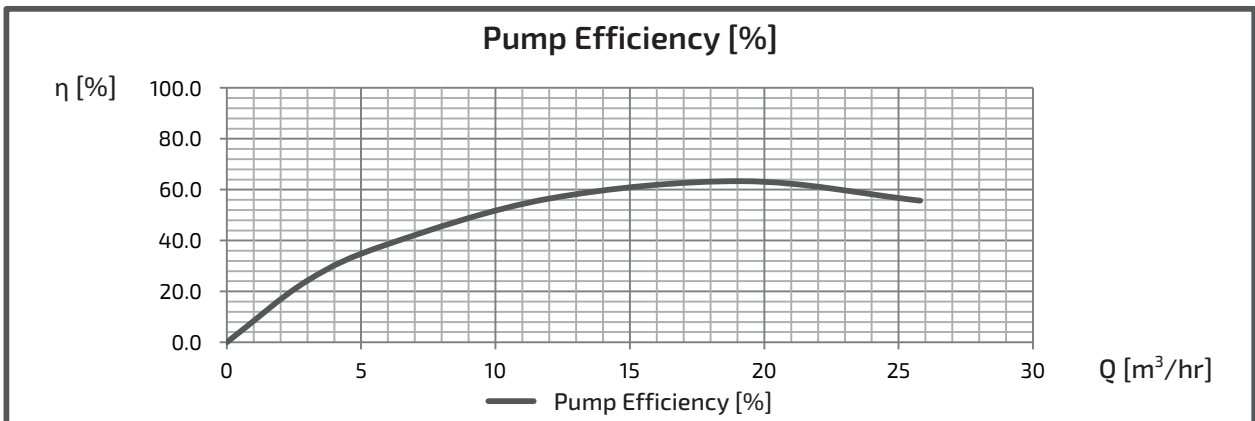
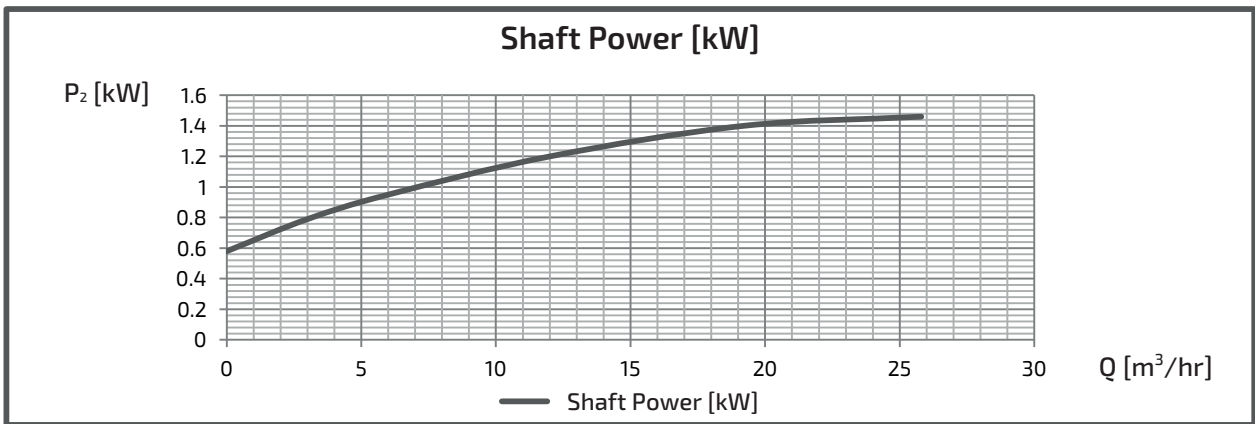
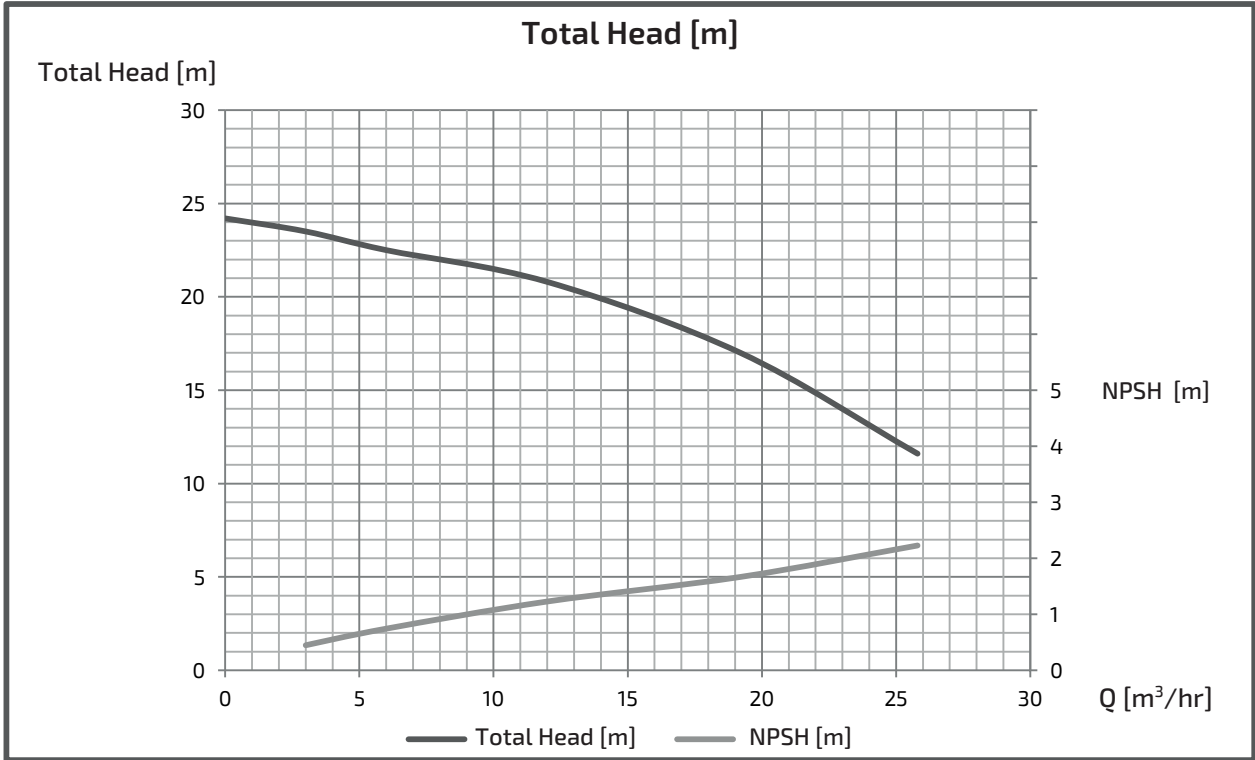

INDIVIDUAL EXPECTED PERFORMANCE CURVE

MODEL : GEJ505M(G)2ME2.2

■ PERFORMANCE CURVES

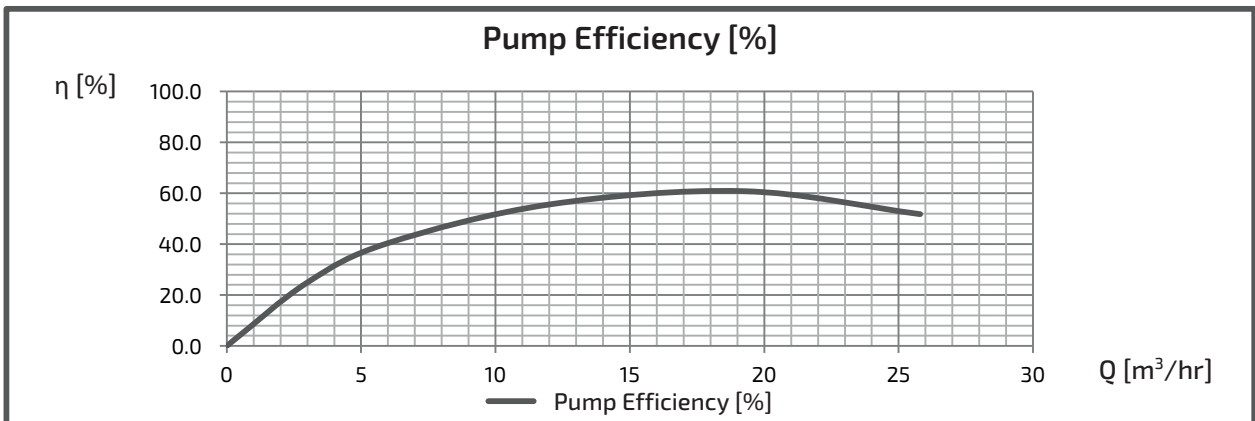
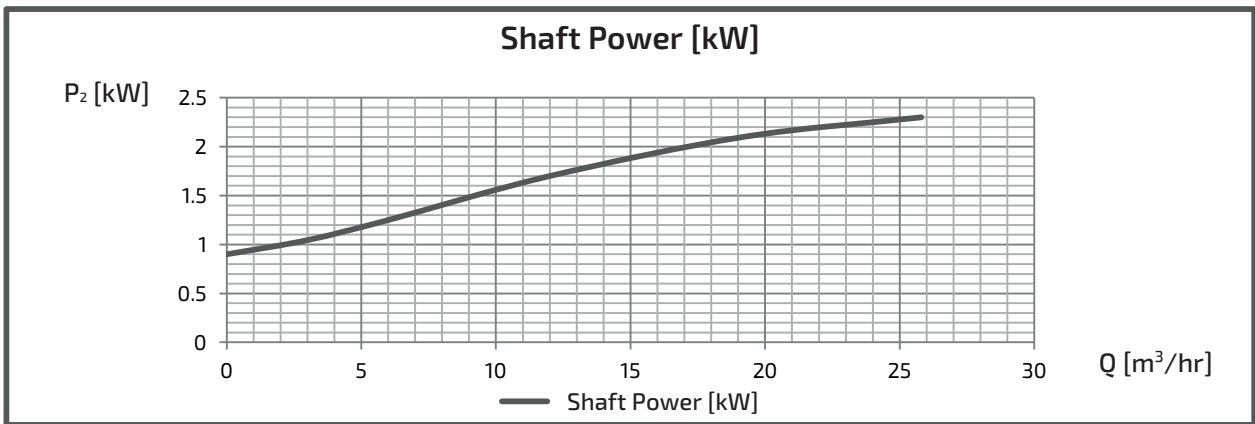
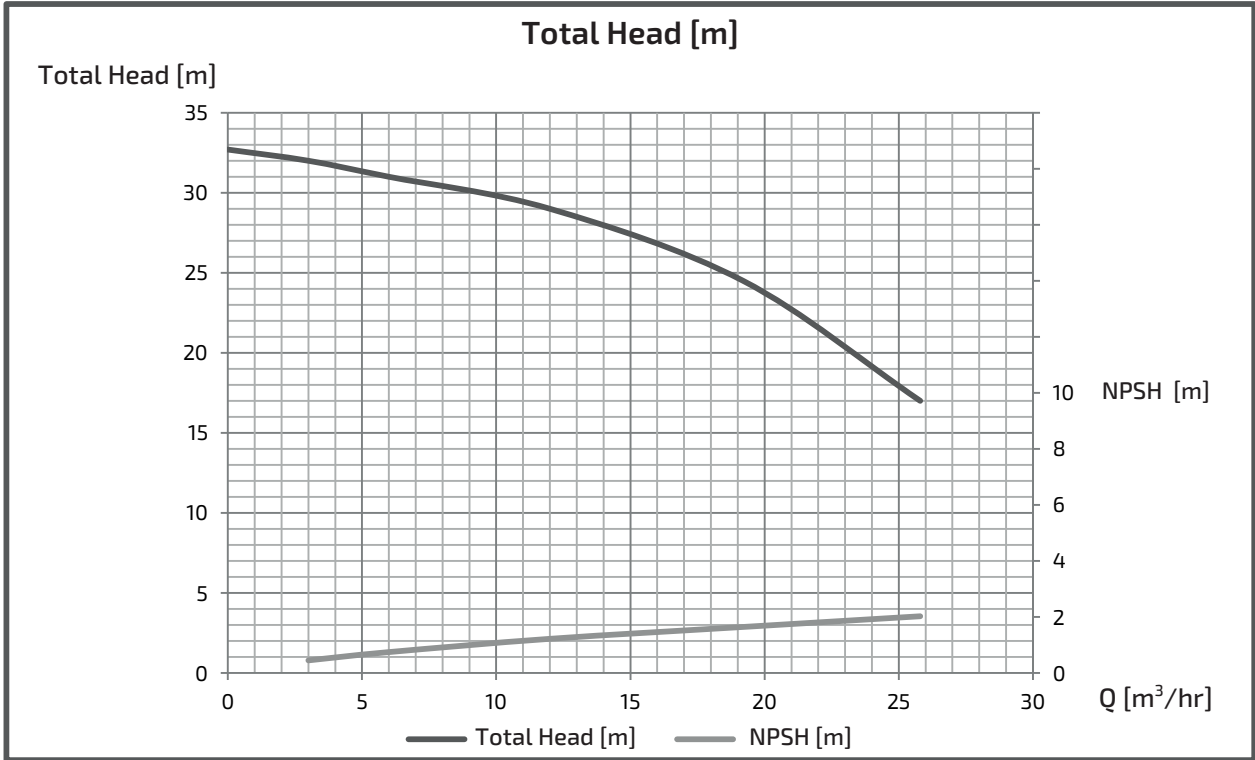

INDIVIDUAL EXPECTED PERFORMANCE CURVE

MODEL : GEJ505M(G)2ME3.7

■ PERFORMANCE CURVES

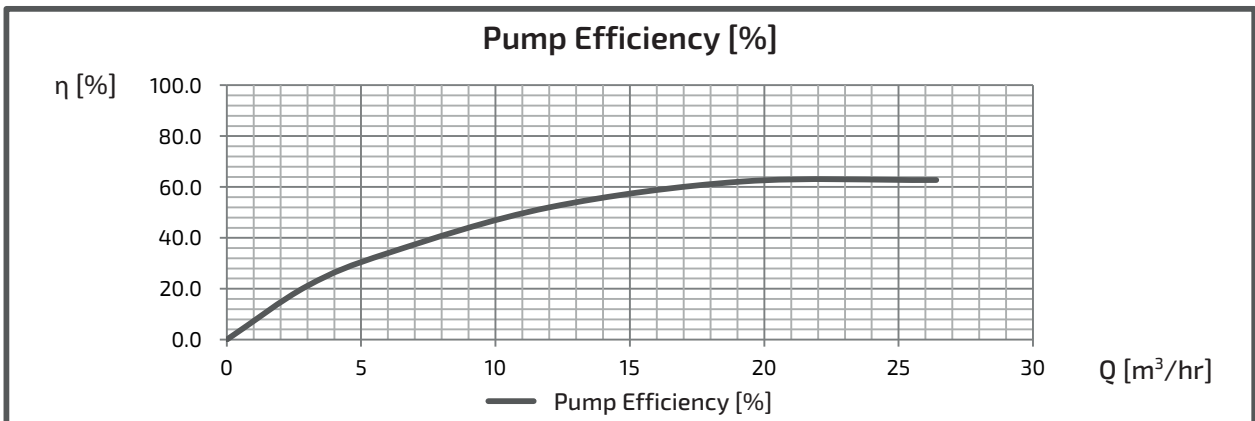
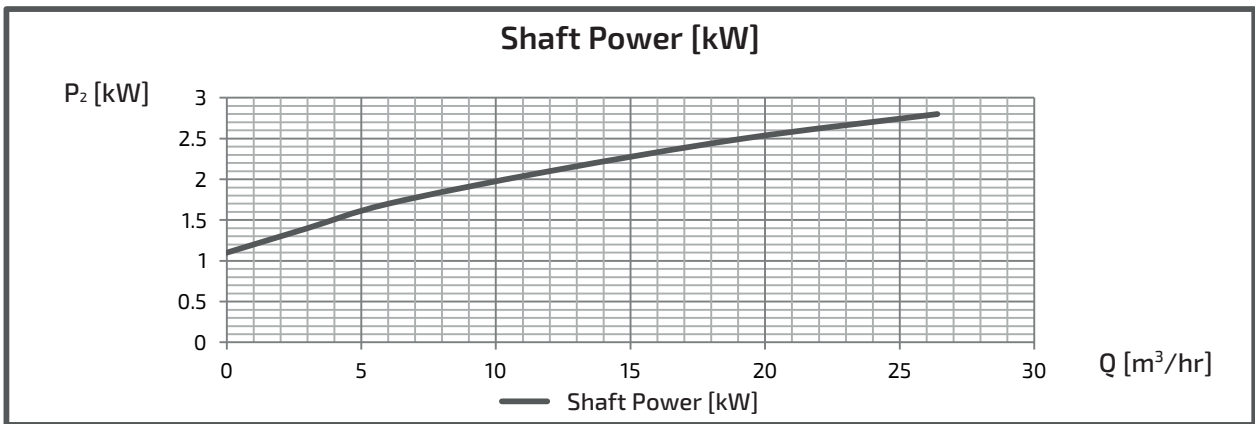
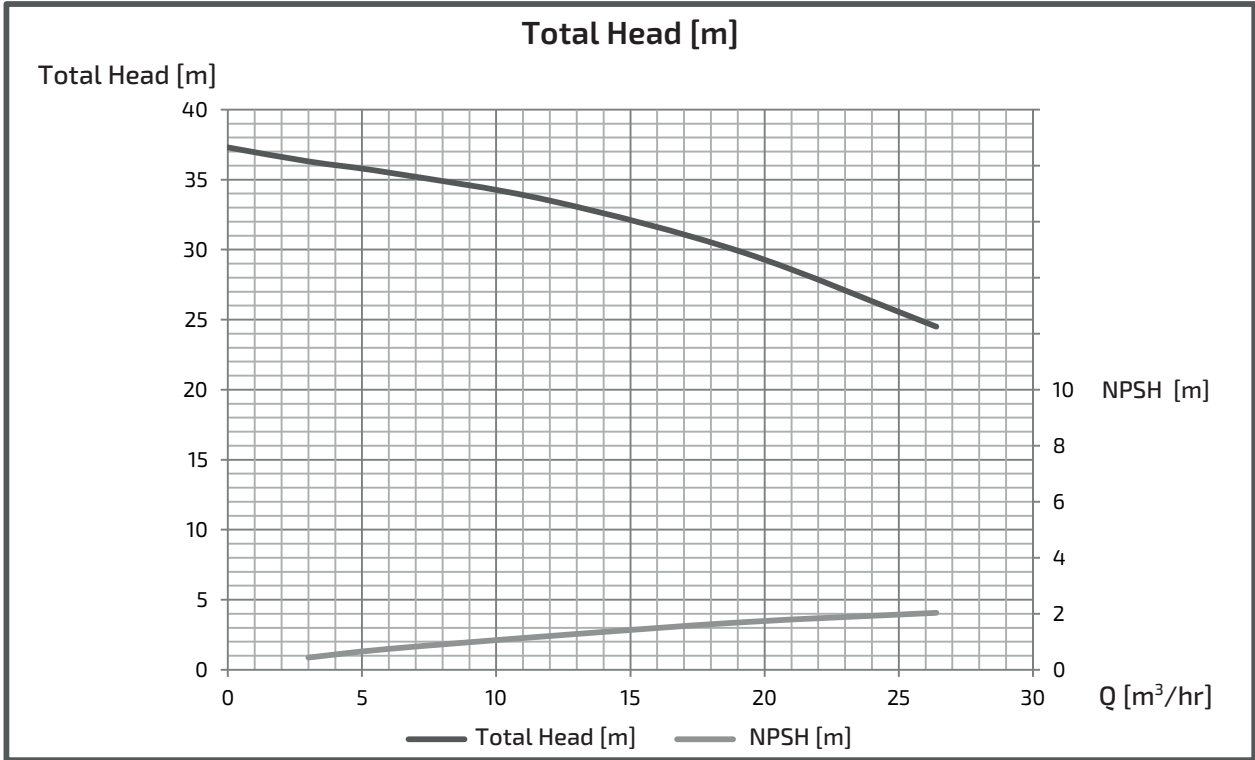

INDIVIDUAL EXPECTED PERFORMANCE CURVE

MODEL : GEK505M(G)2ME3.7

■ PERFORMANCE CURVES

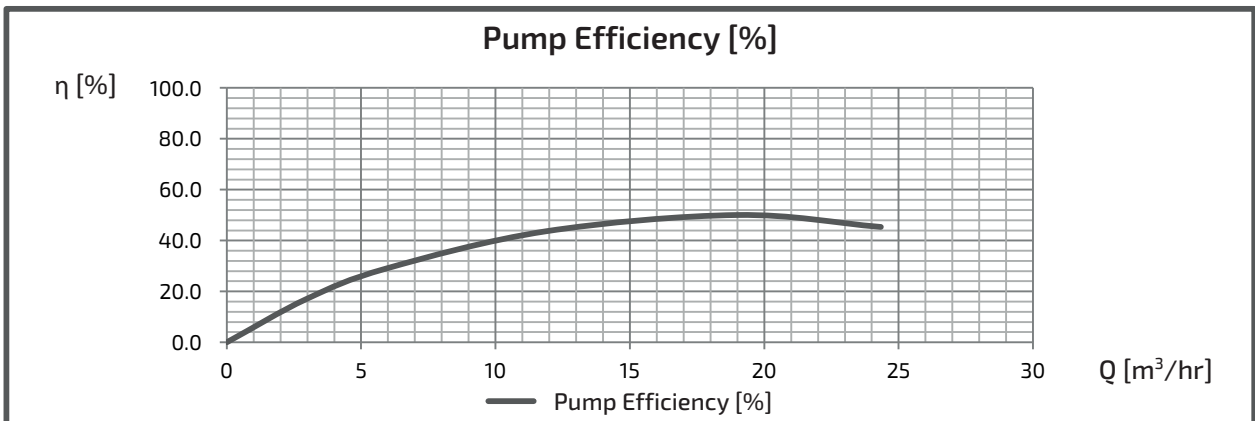
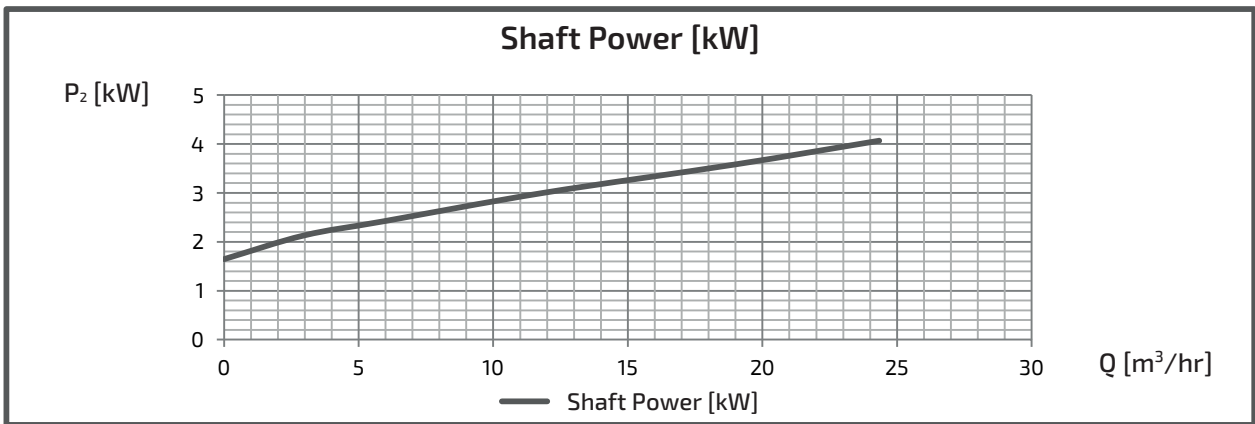
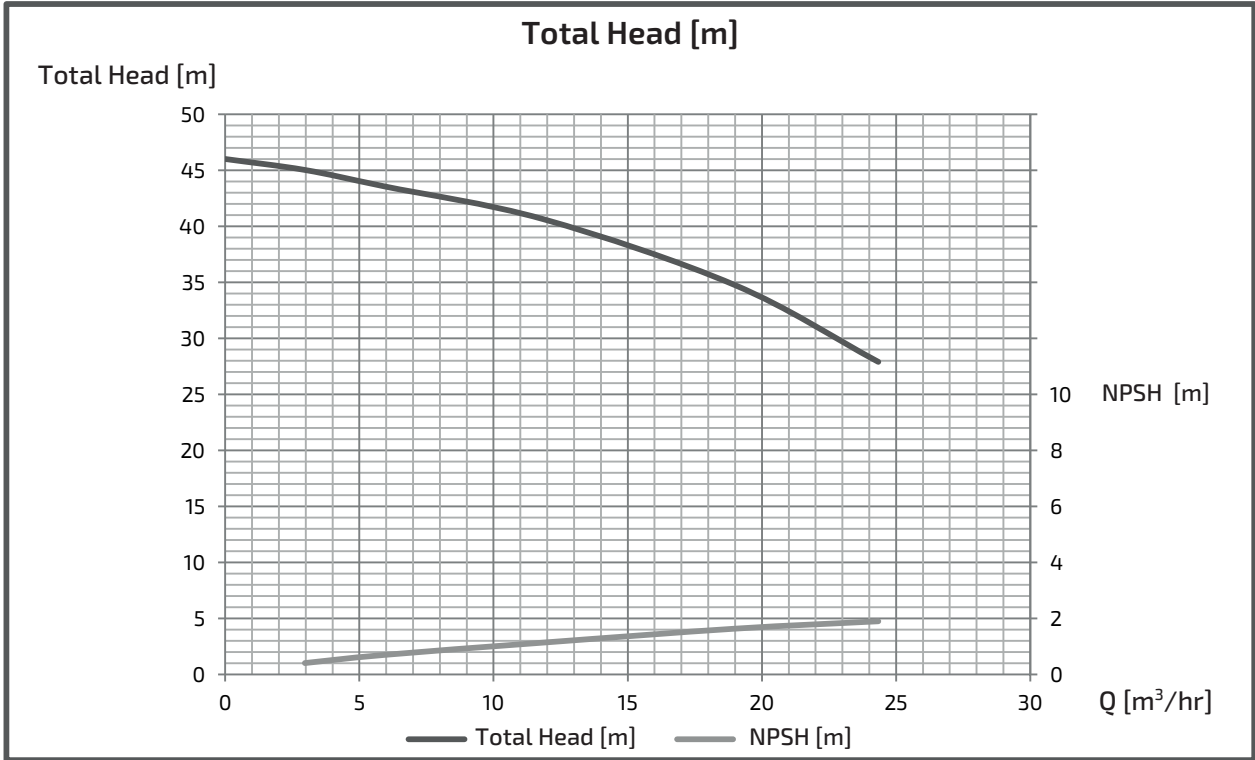

INDIVIDUAL EXPECTED PERFORMANCE CURVE

MODEL : GEK505M(G)2ME5.5

■ PERFORMANCE CURVES

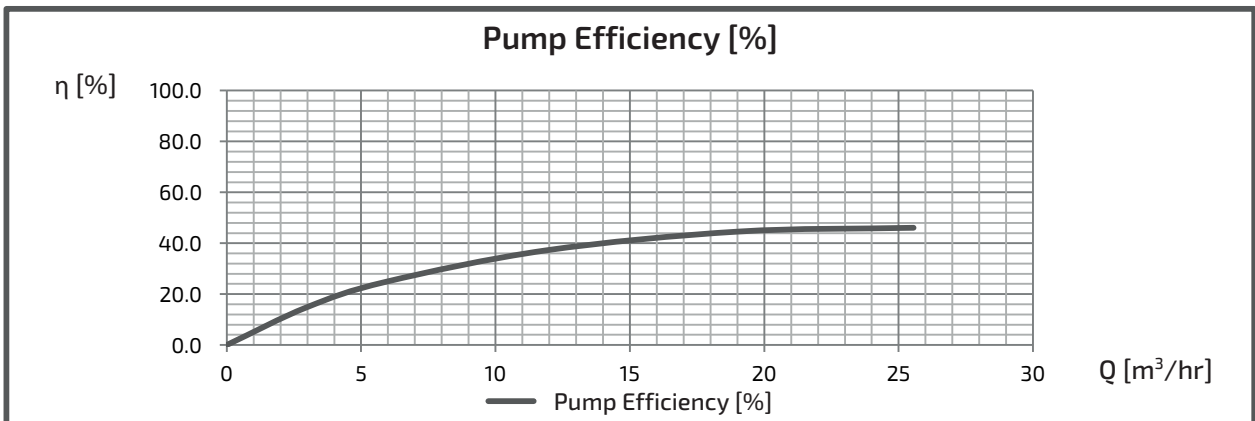
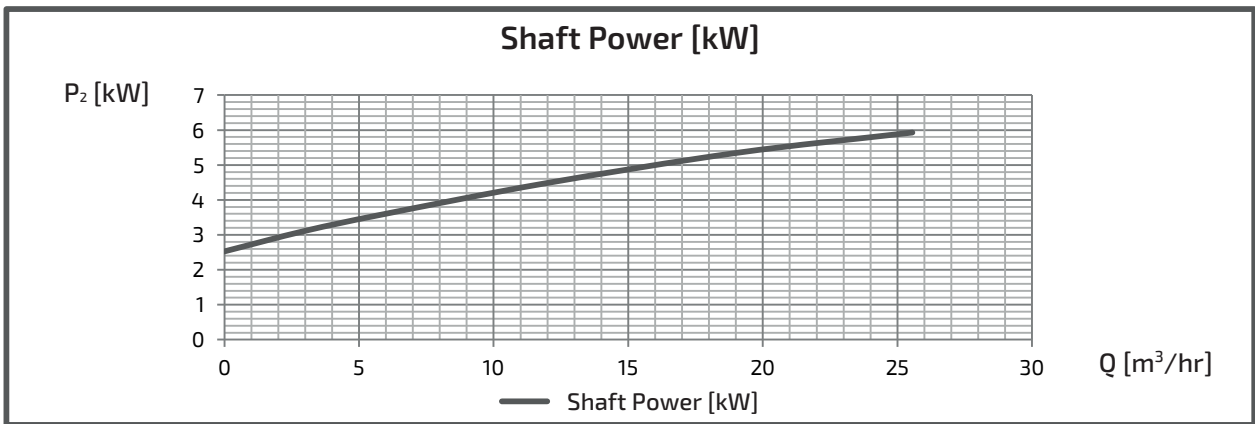
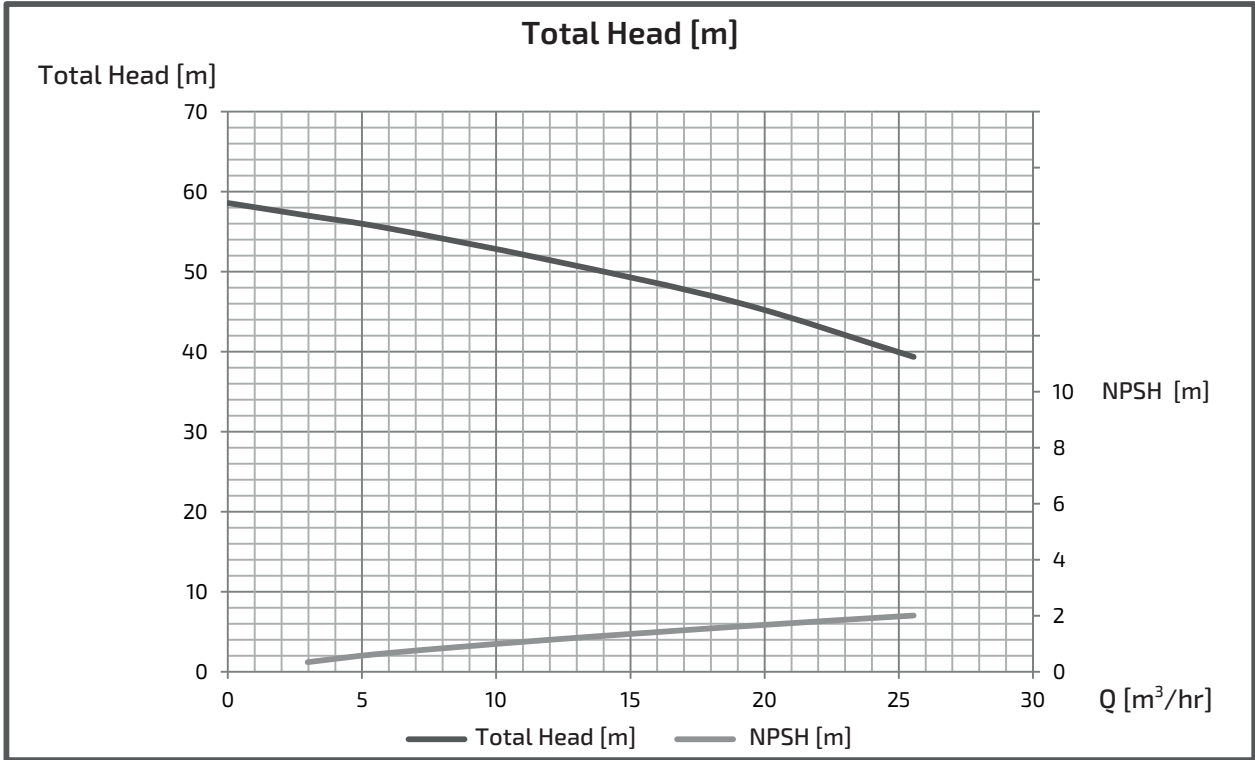

INDIVIDUAL EXPECTED PERFORMANCE CURVE

MODEL : GEH655M(G)2ME0.75

■ PERFORMANCE CURVES

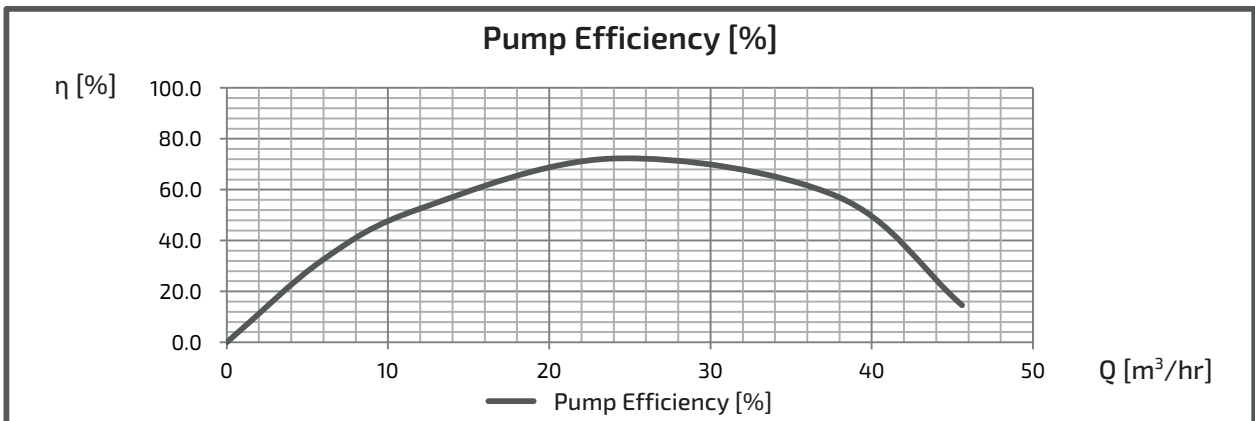
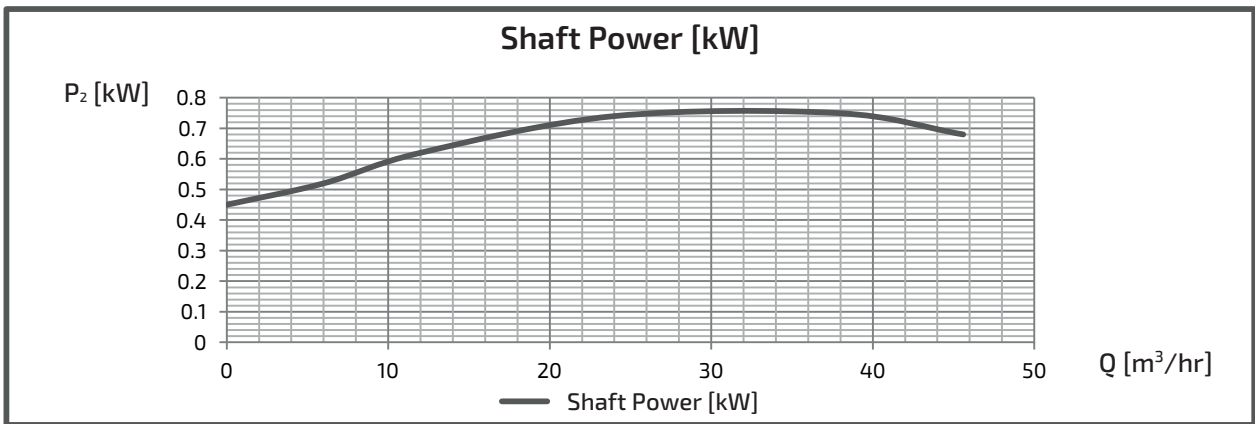
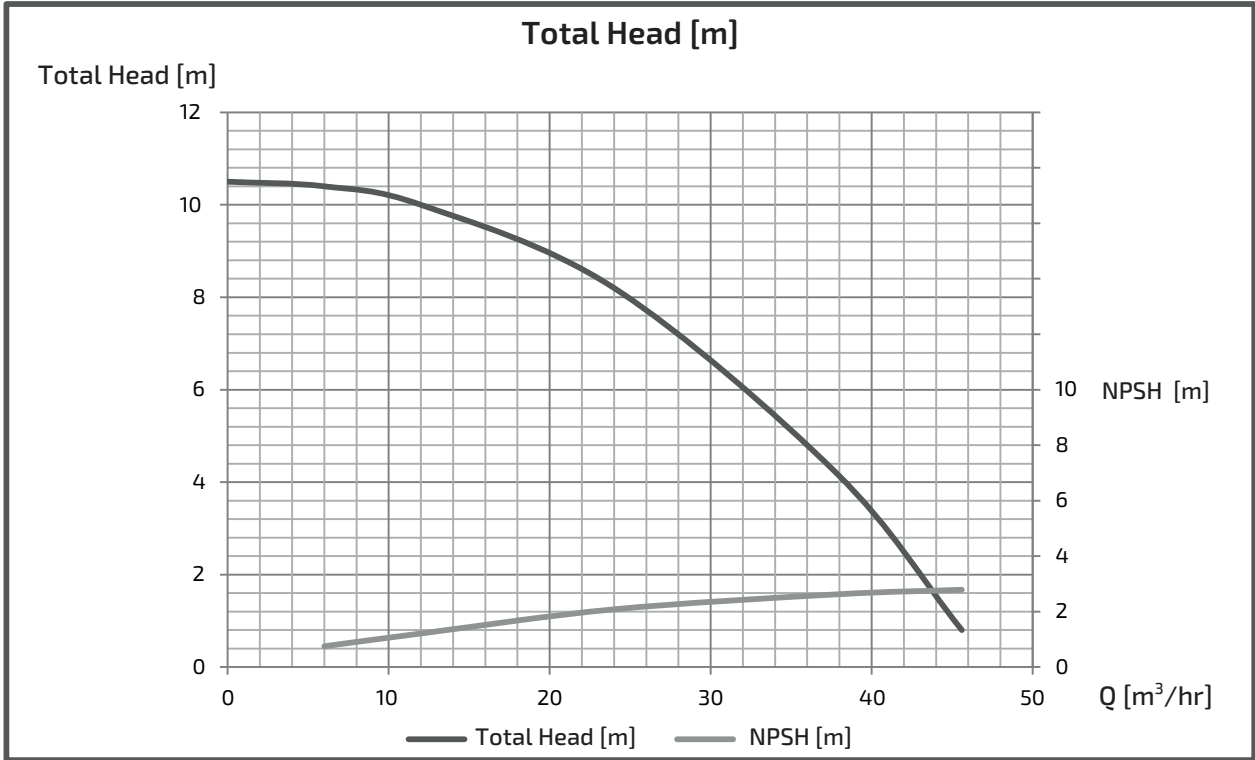

INDIVIDUAL EXPECTED PERFORMANCE CURVE

MODEL : GEH655M(G)2ME1.5

■ PERFORMANCE CURVES

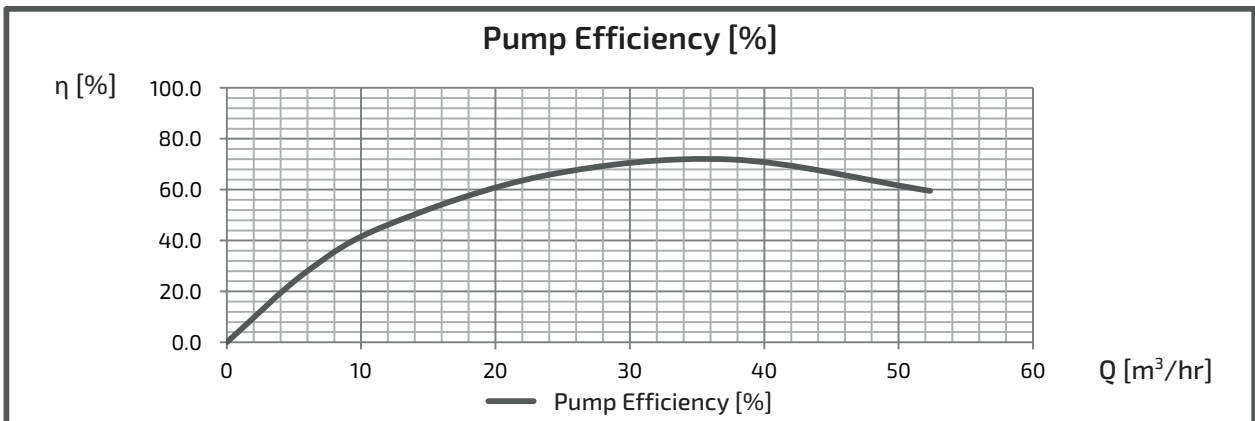
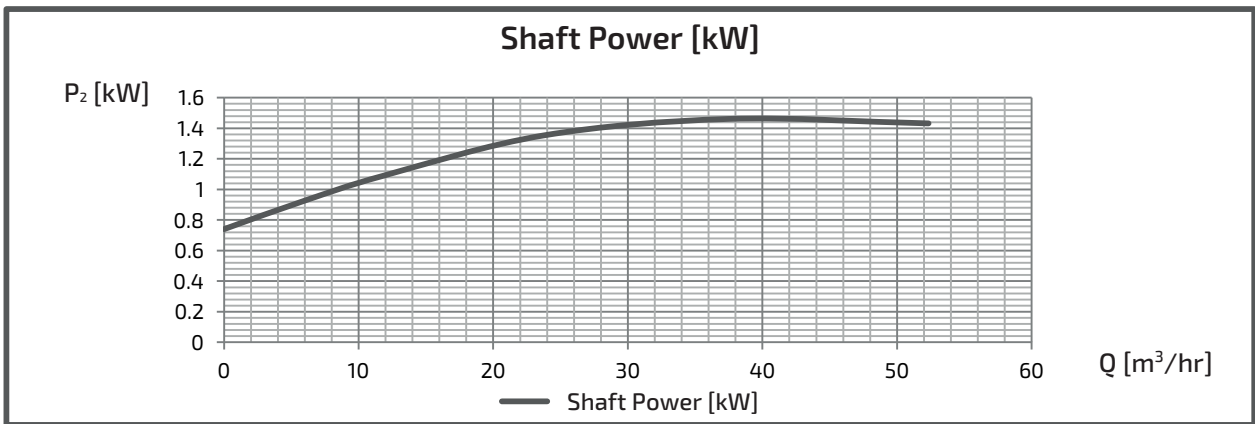
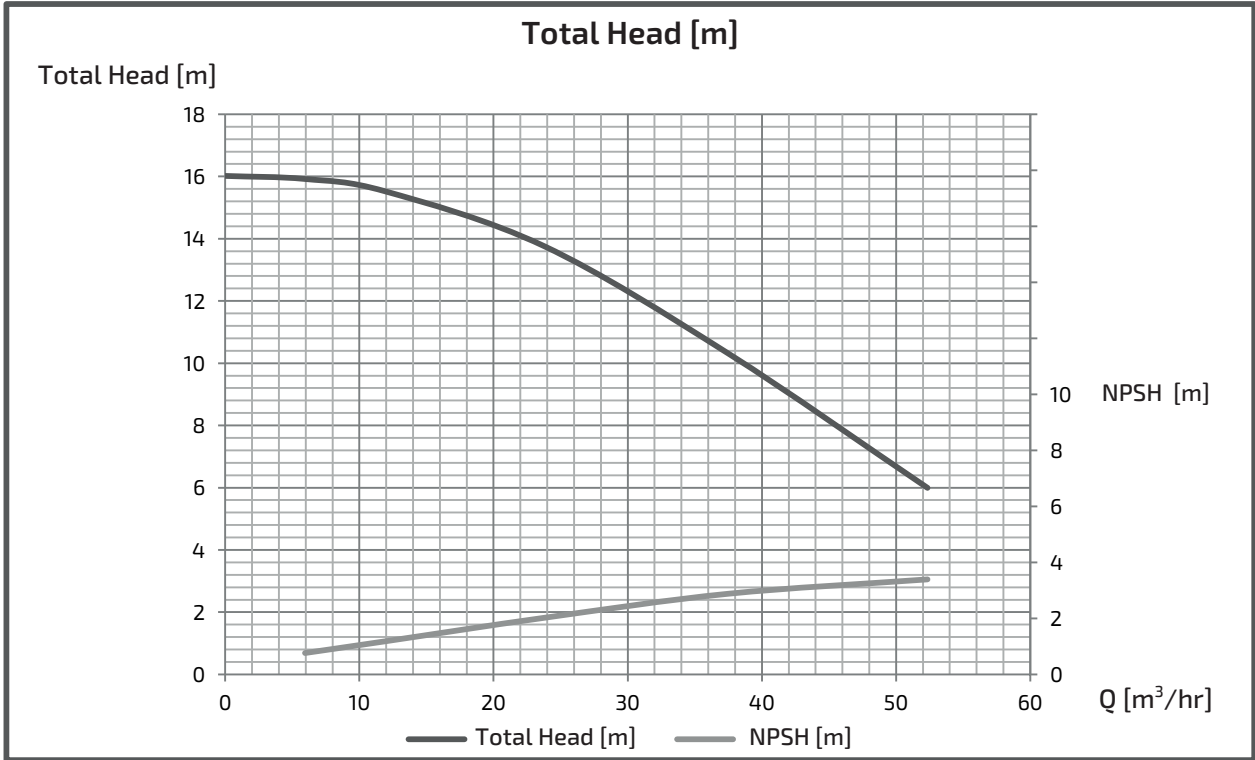

INDIVIDUAL EXPECTED PERFORMANCE CURVE

MODEL : GEI655M(G)2ME2.2

■ PERFORMANCE CURVES

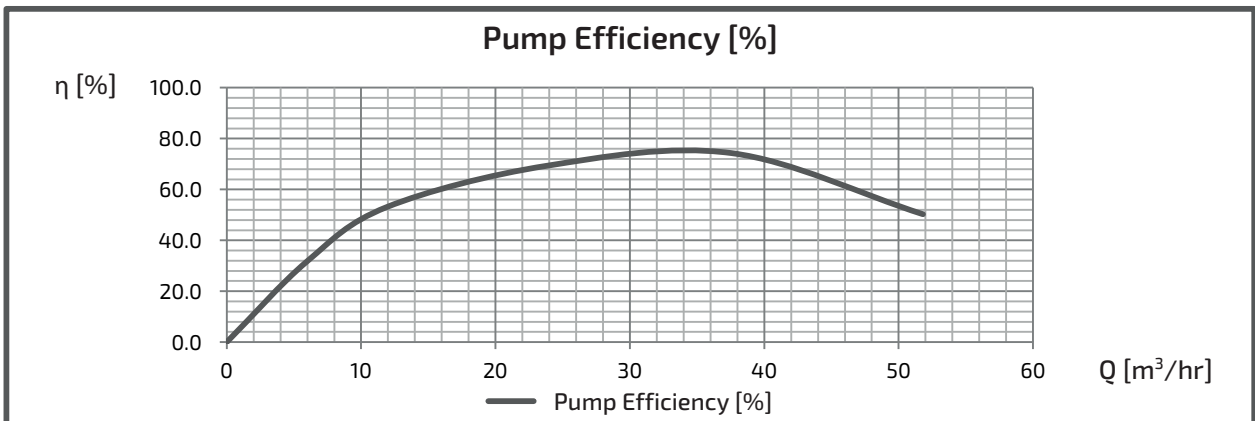
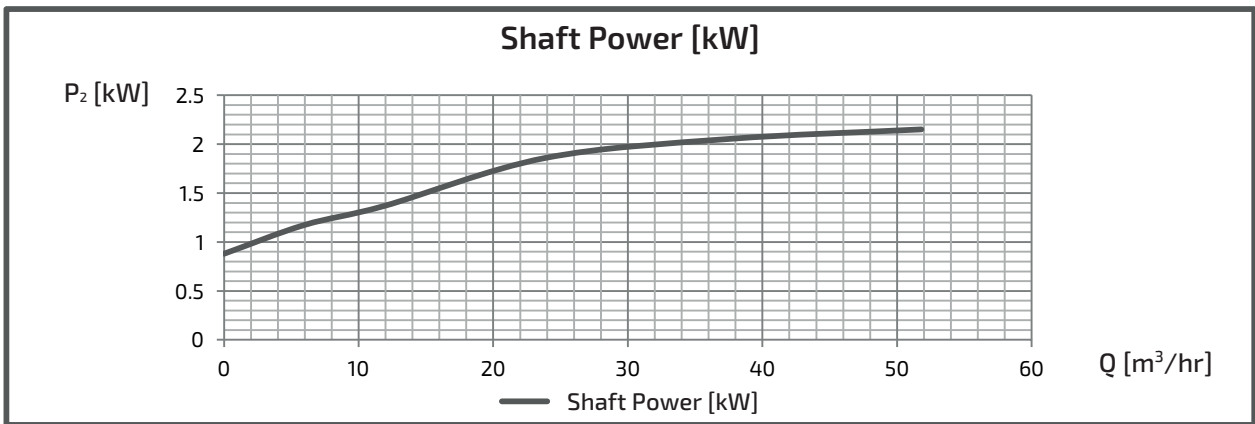
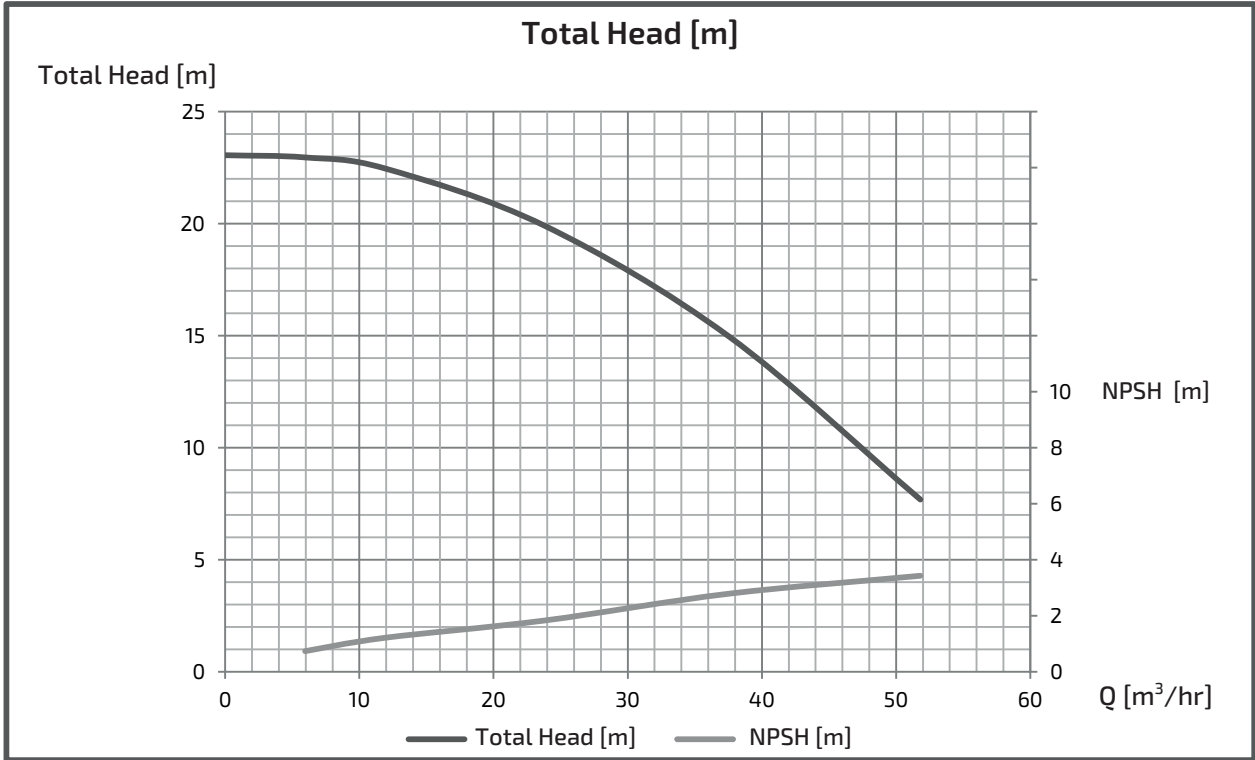

INDIVIDUAL EXPECTED PERFORMANCE CURVE

MODEL : GEJ65M(G)2ME3.7

■ PERFORMANCE CURVES

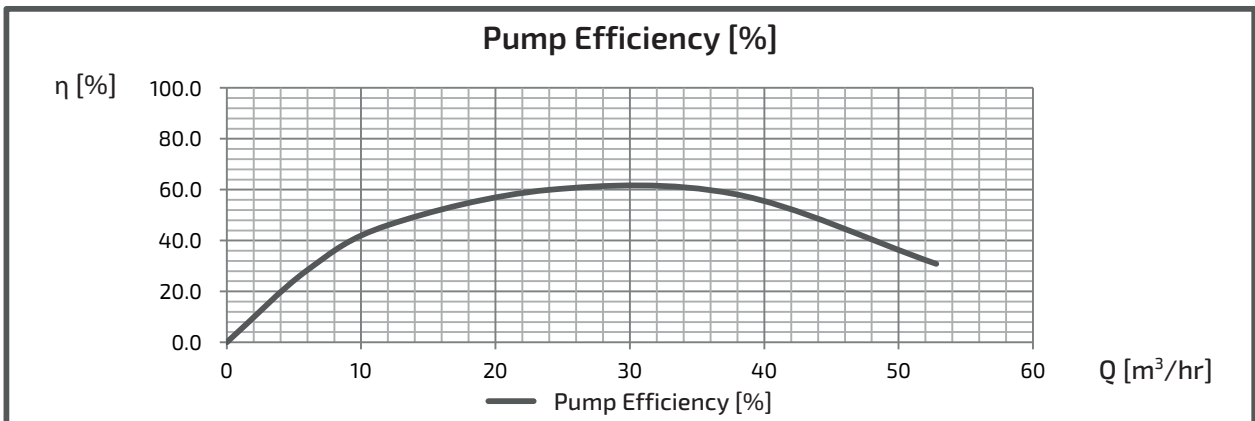
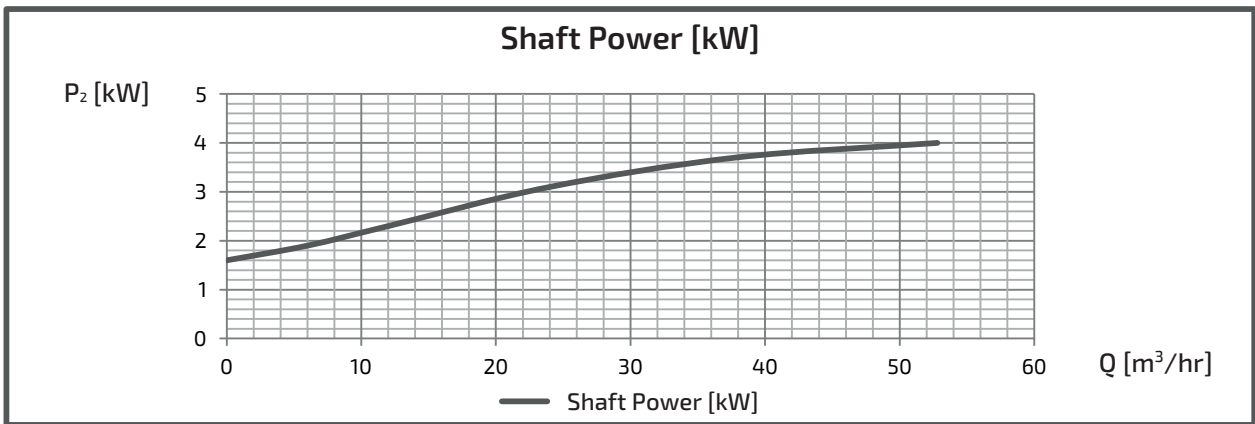
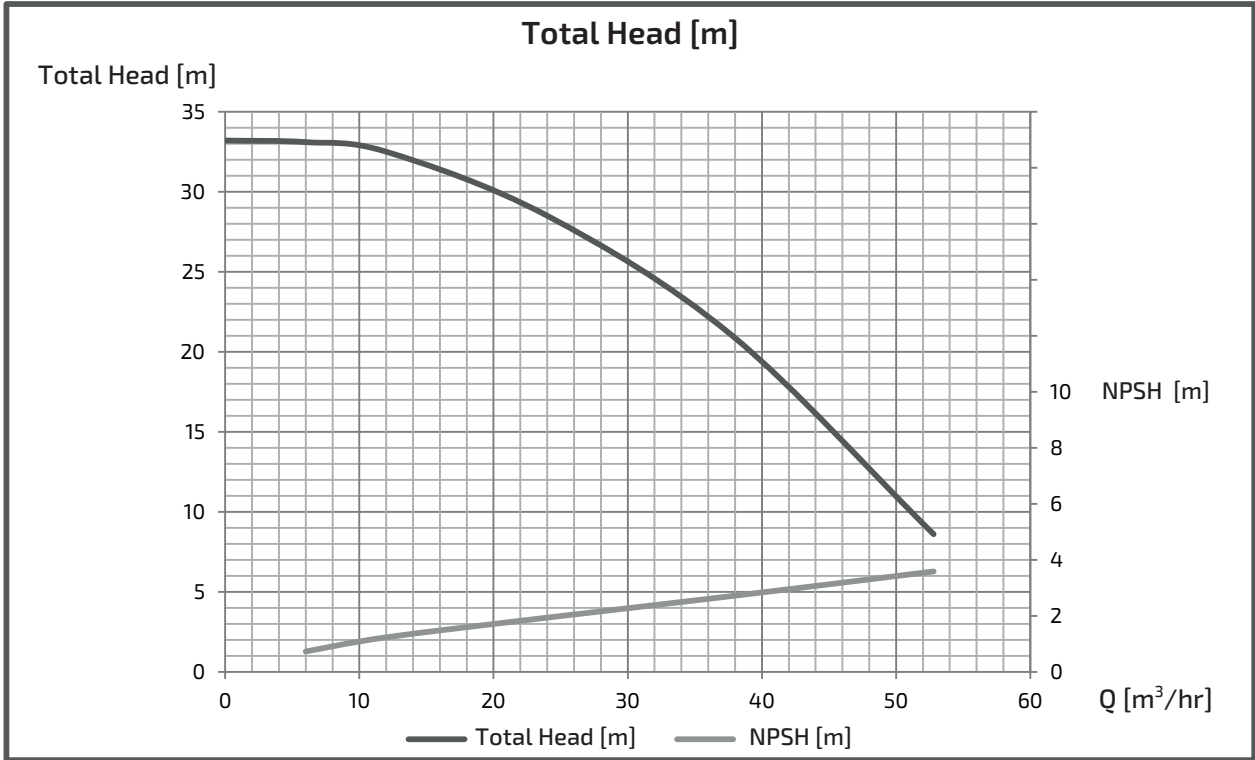

INDIVIDUAL EXPECTED PERFORMANCE CURVE

MODEL : GEK655M(G)2ME5.5

■ PERFORMANCE CURVES

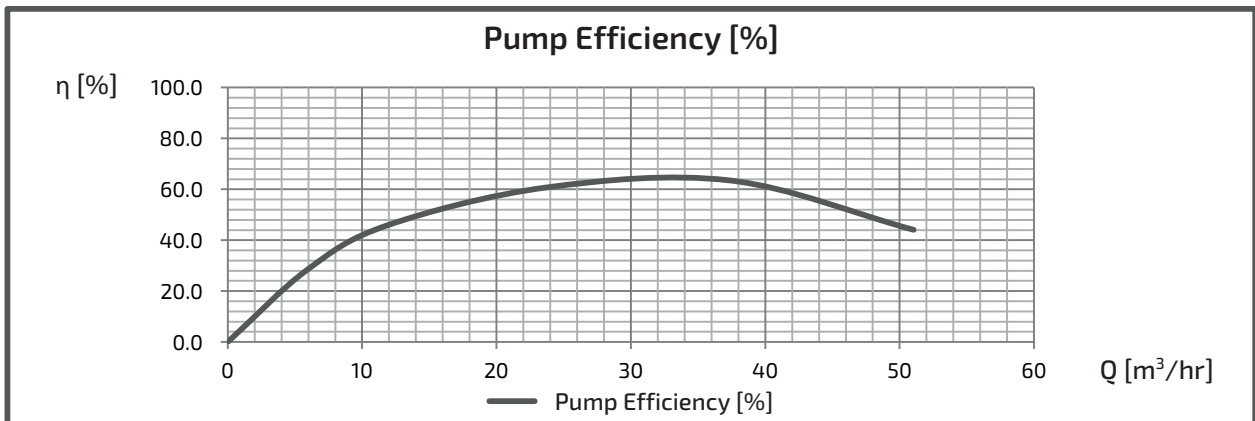
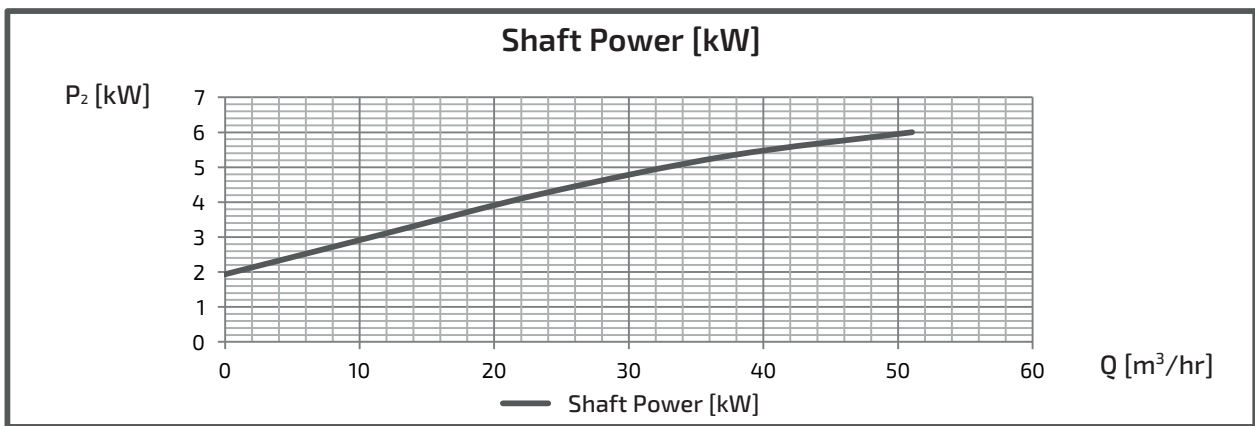
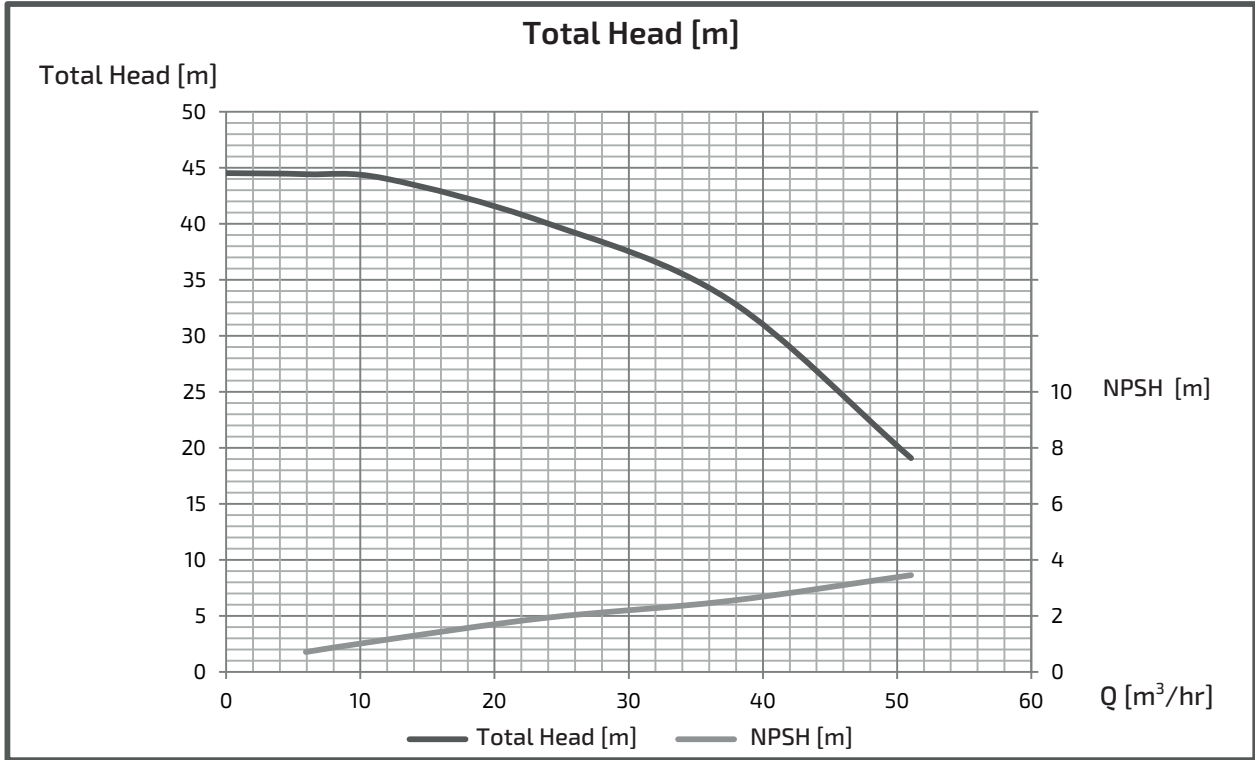

INDIVIDUAL EXPECTED PERFORMANCE CURVE

MODEL : GEK655M(G)2ME7.5

■ PERFORMANCE CURVES

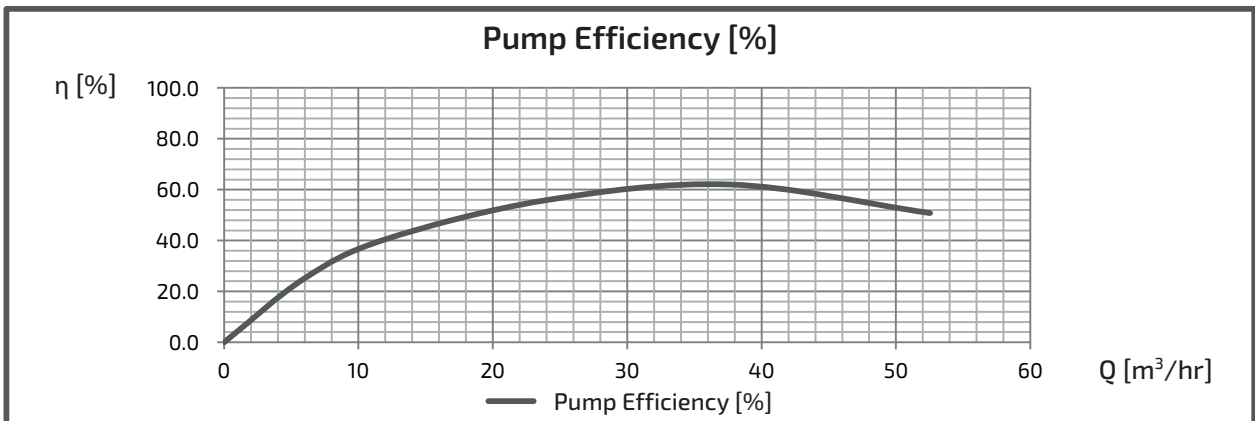
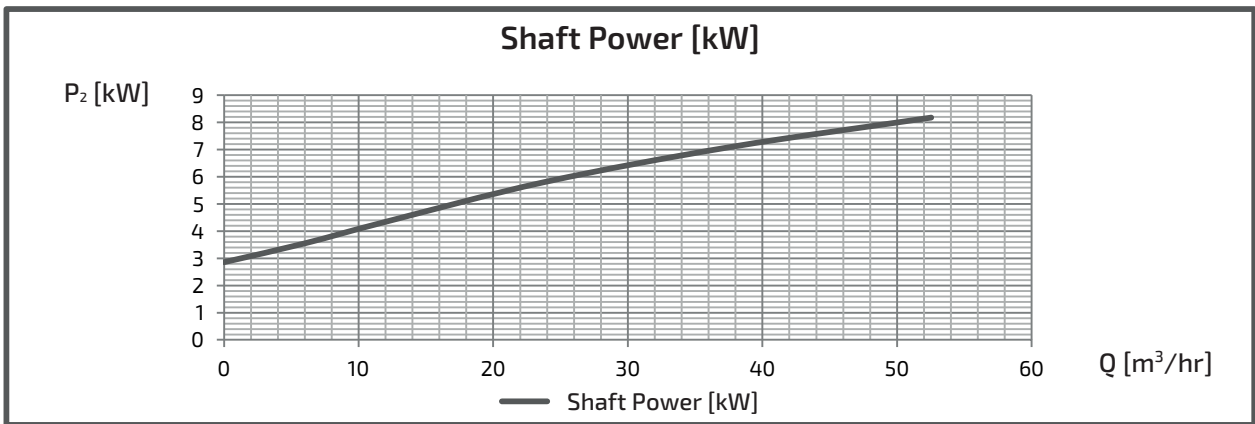
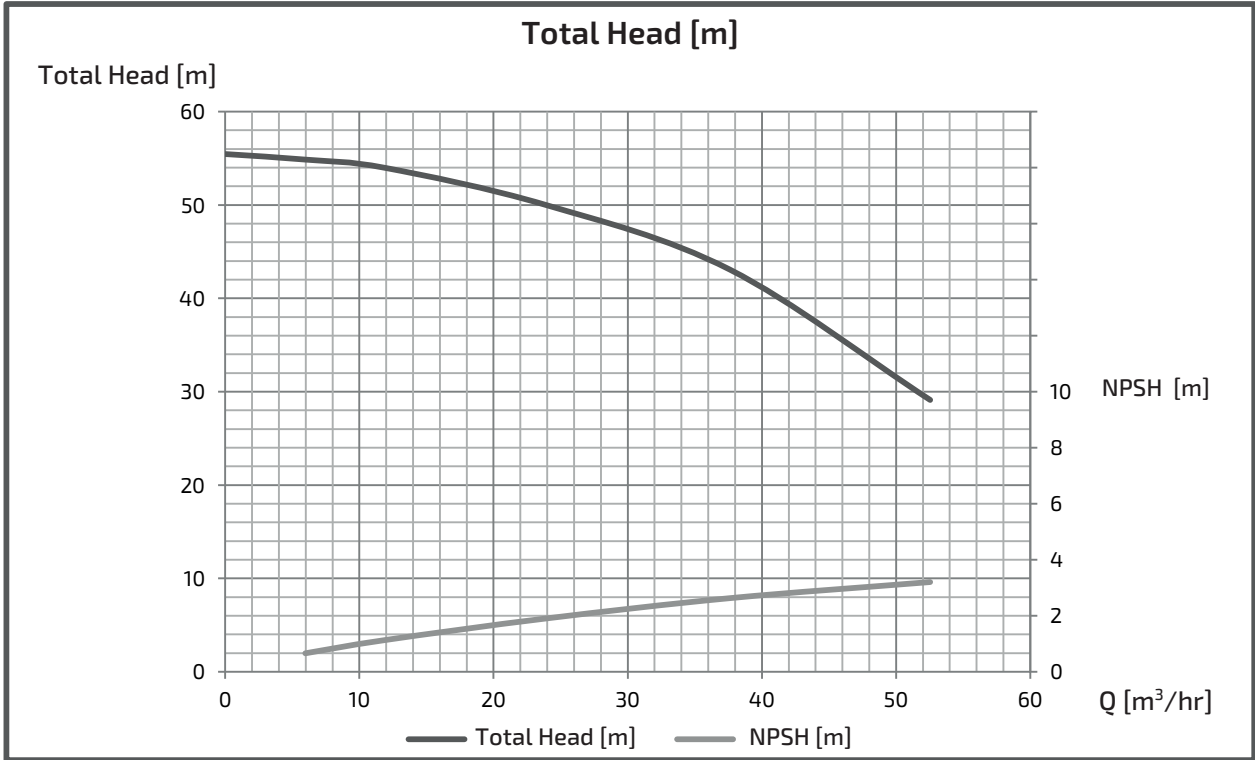

INDIVIDUAL EXPECTED PERFORMANCE CURVE

MODEL : GEL65M(G)2ME11

■ PERFORMANCE CURVES

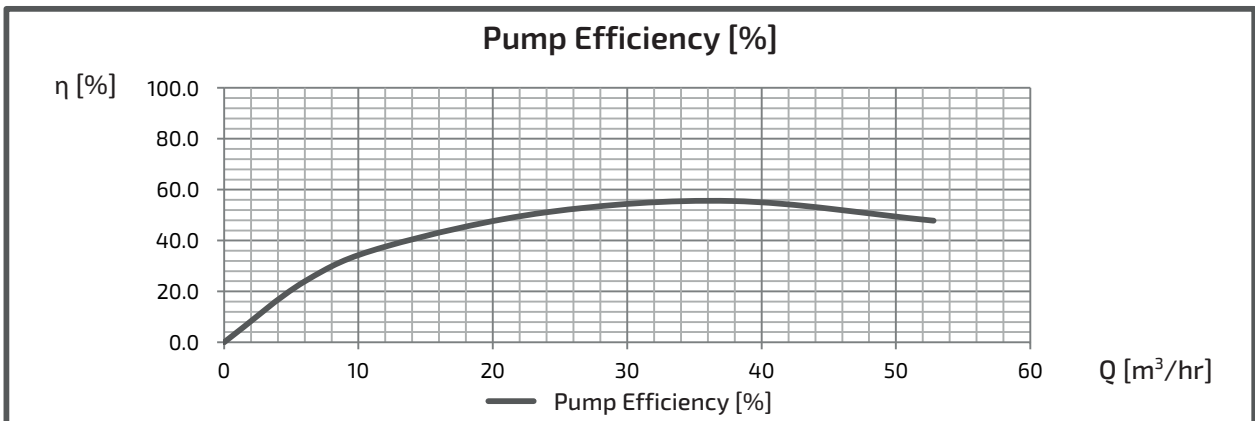
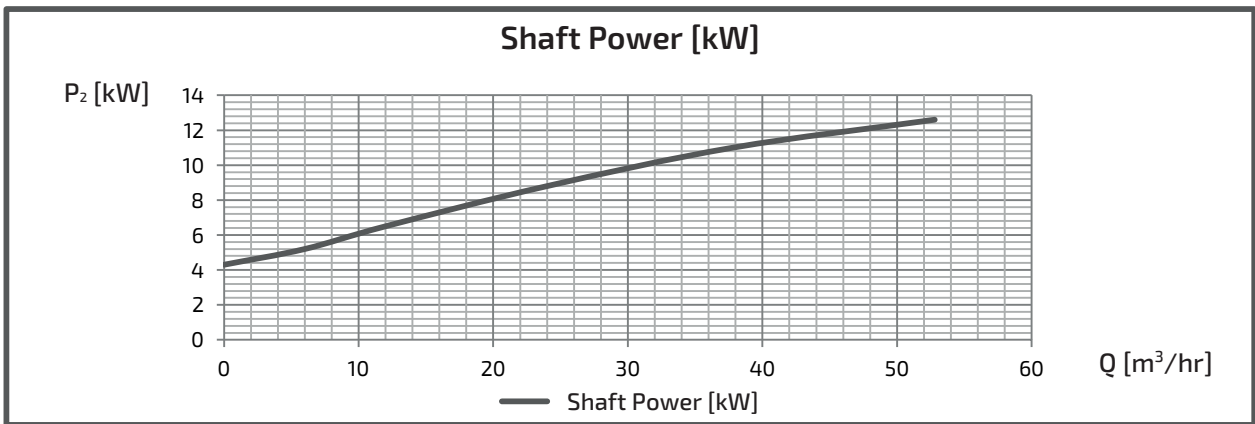
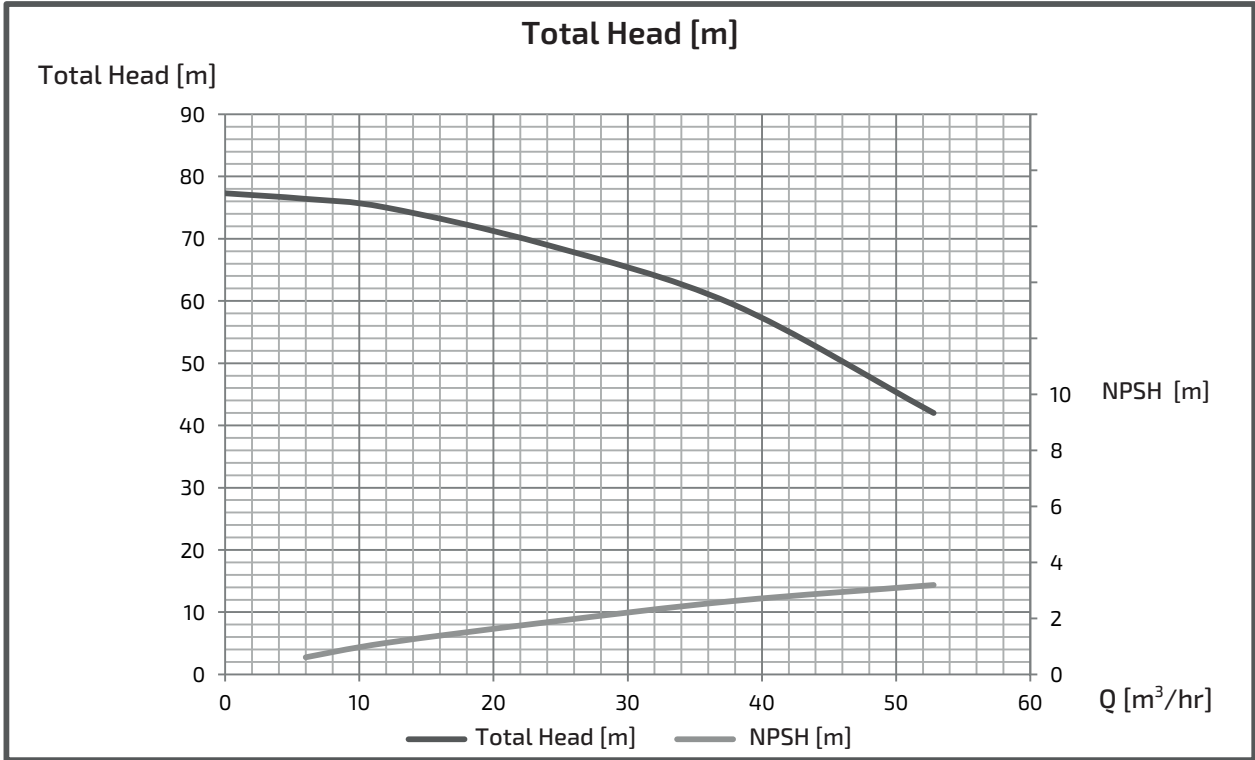

INDIVIDUAL EXPECTED PERFORMANCE CURVE

MODEL : GEL65M(G)2ME15

■ PERFORMANCE CURVES

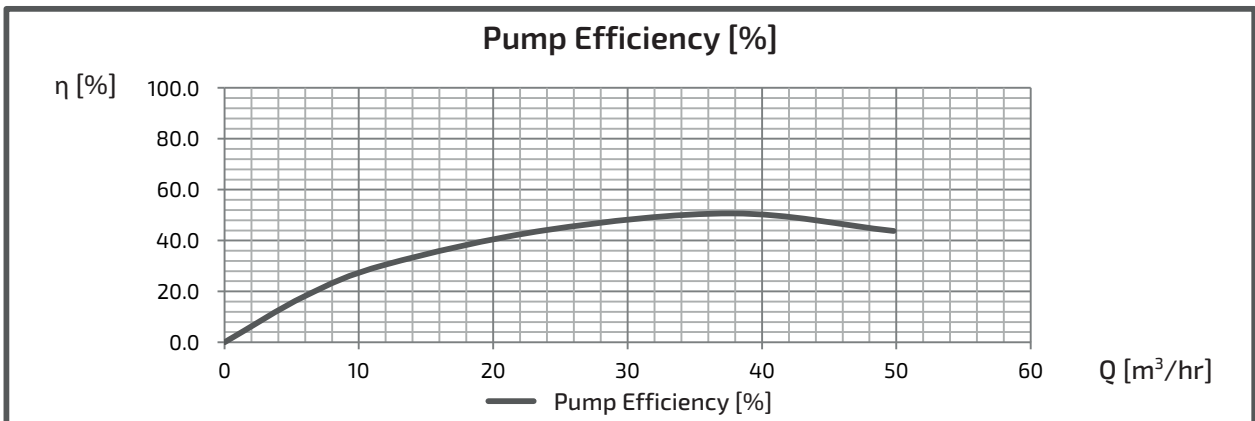
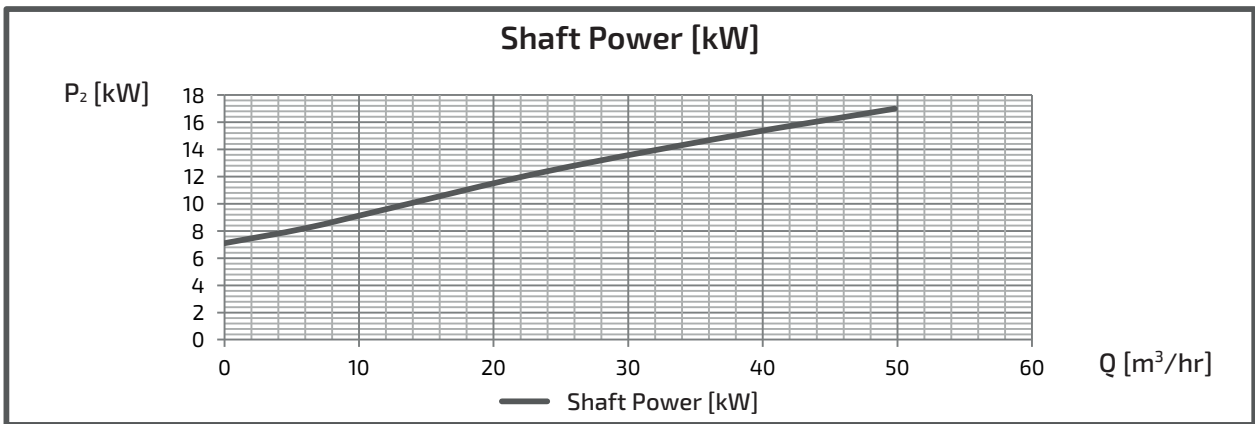
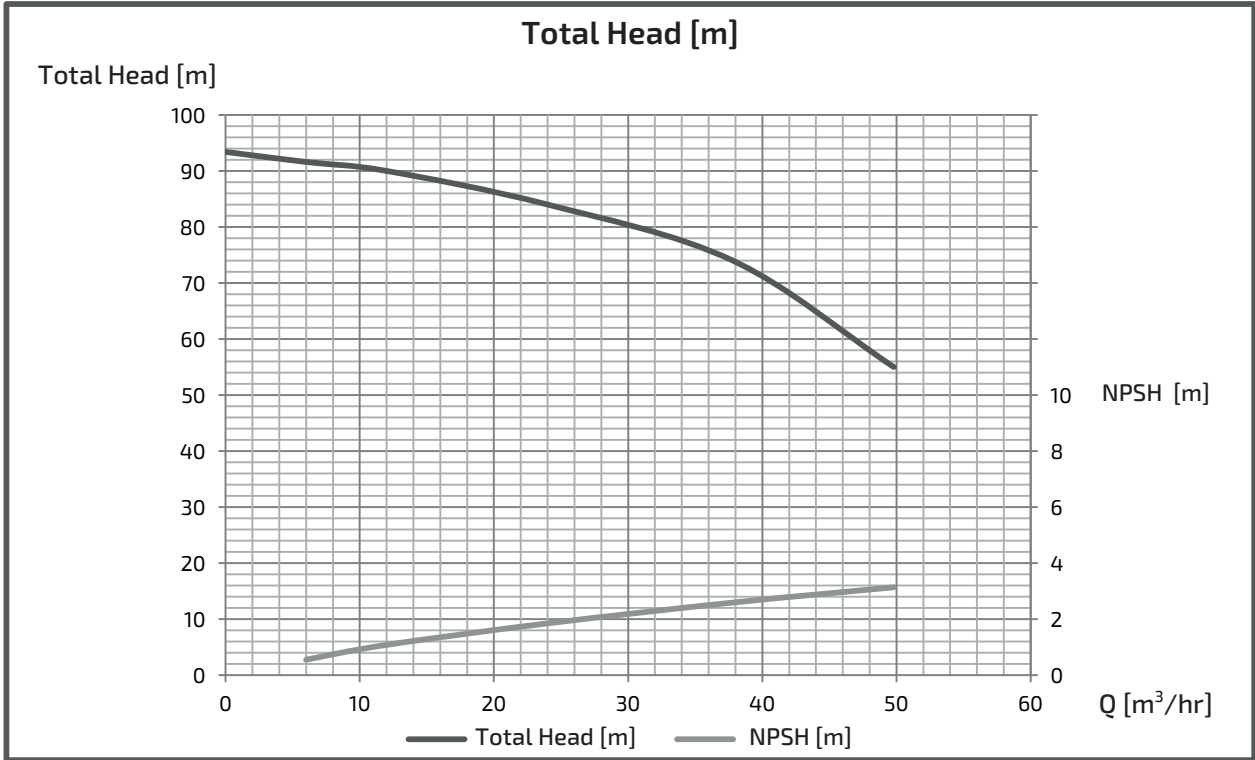

INDIVIDUAL EXPECTED PERFORMANCE CURVE

MODEL : GEH805M(G)2ME2.2

■ PERFORMANCE CURVES

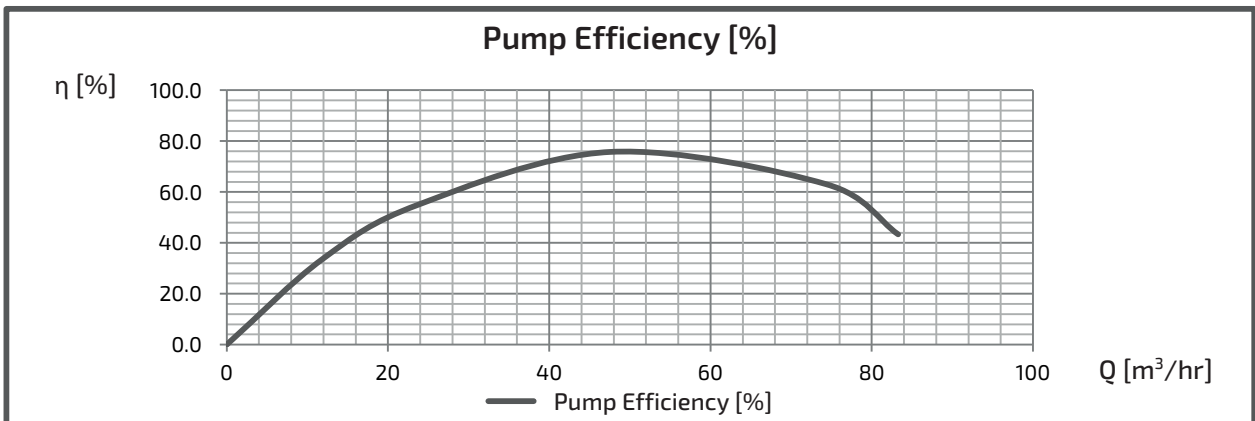
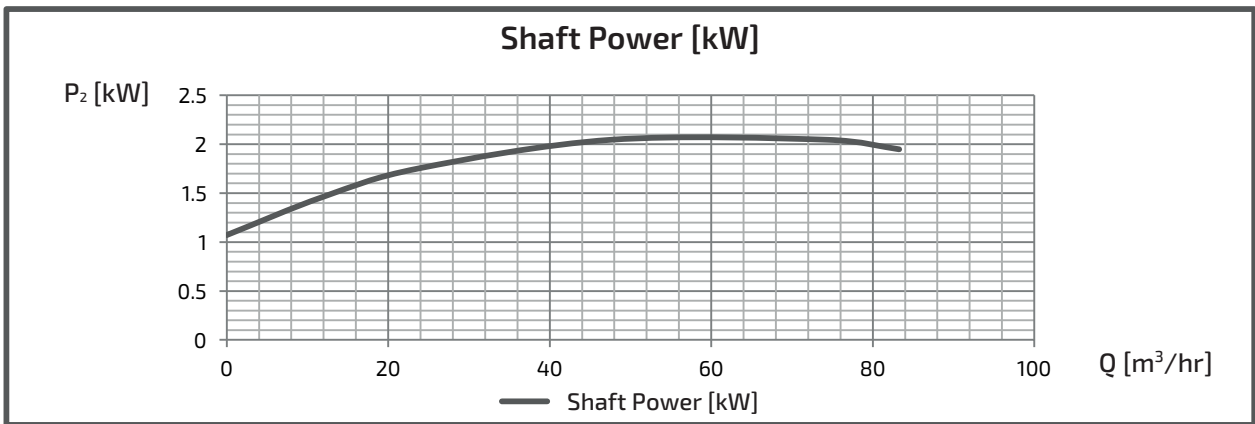
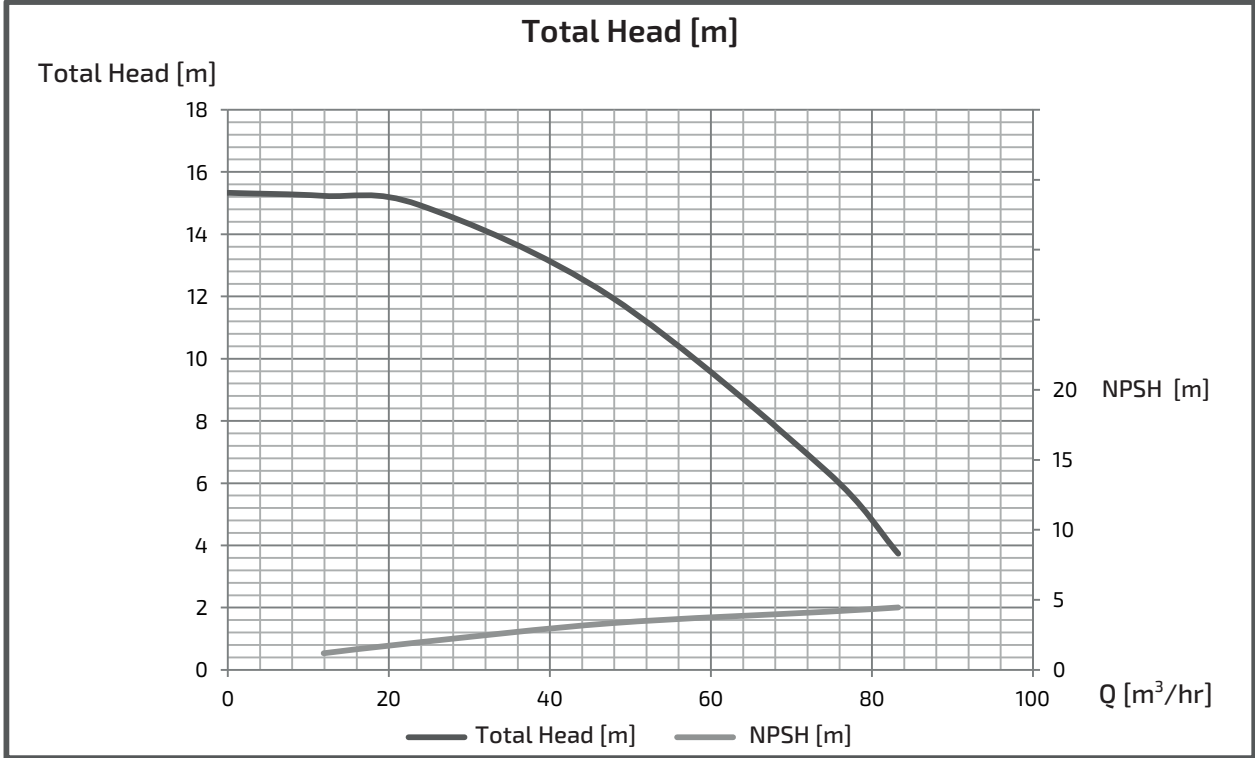

INDIVIDUAL EXPECTED PERFORMANCE CURVE

MODEL : GEI805M(G)2ME3.7

■ PERFORMANCE CURVES

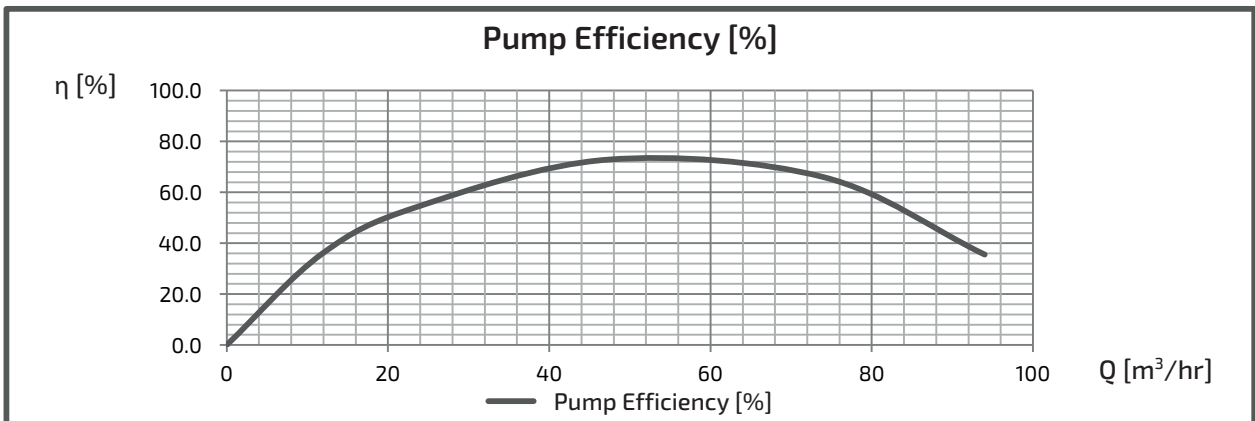
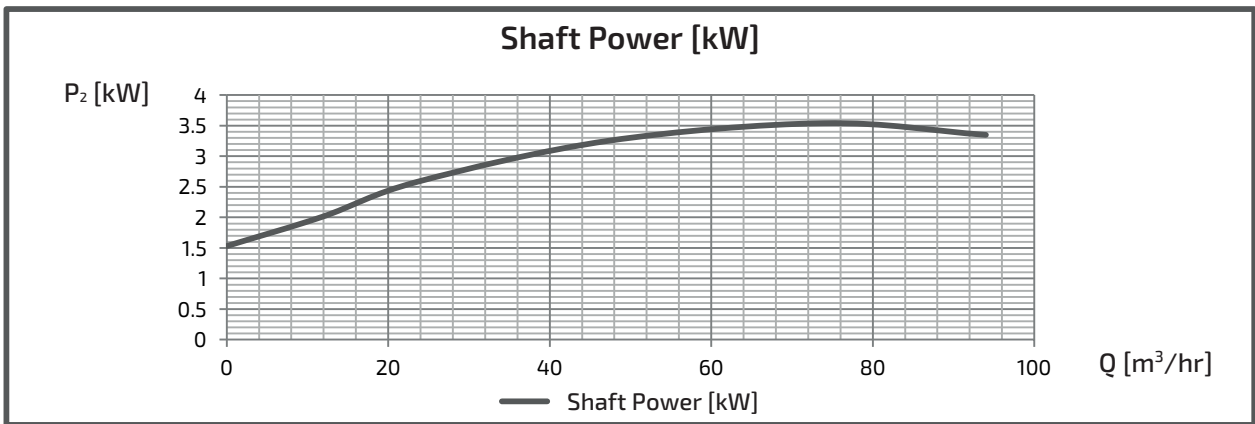
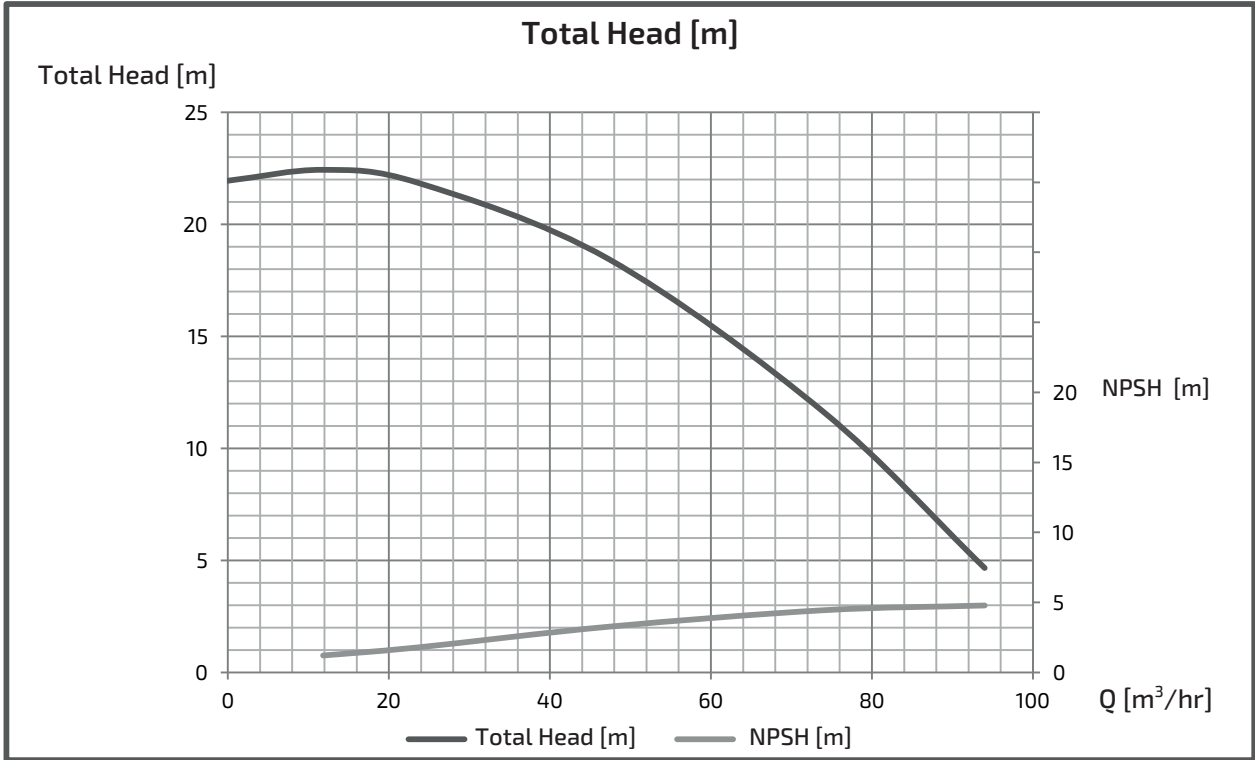

INDIVIDUAL EXPECTED PERFORMANCE CURVE

MODEL : GEJ805M(G)2ME5.5

■ PERFORMANCE CURVES

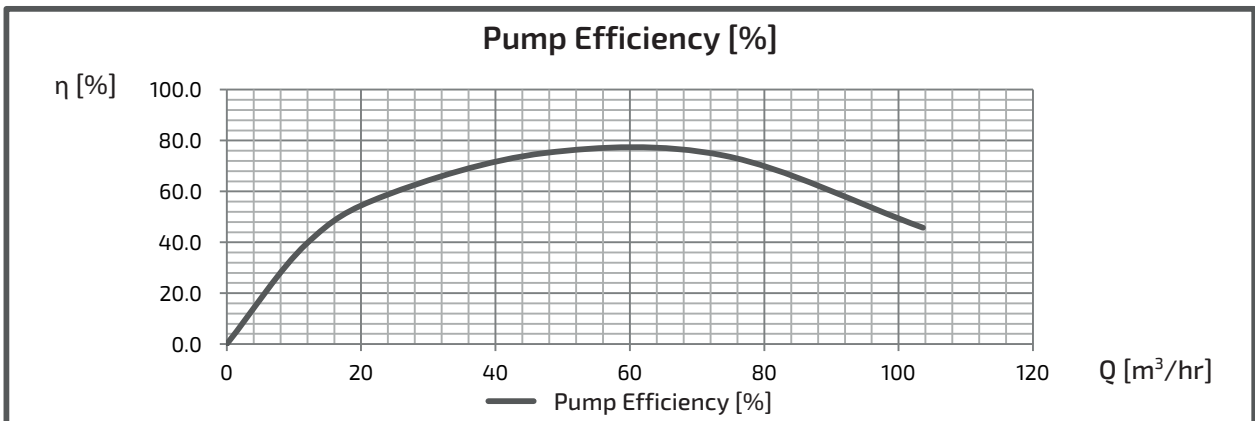
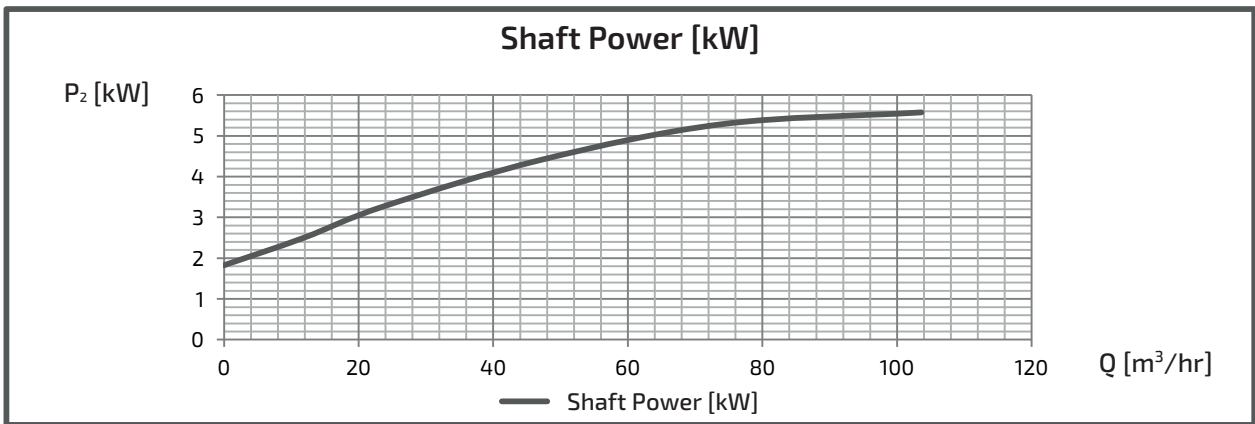
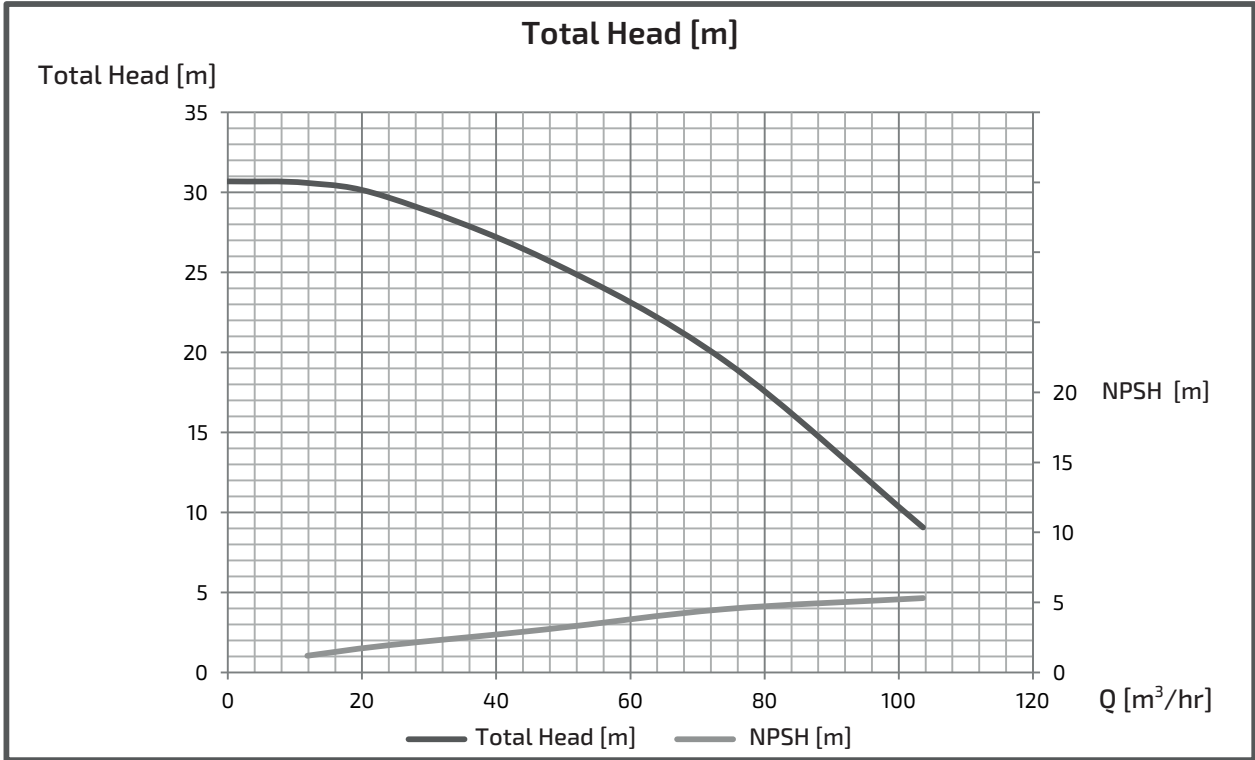

INDIVIDUAL EXPECTED PERFORMANCE CURVE

MODEL : GEJ805M(G)2ME7.5

■ PERFORMANCE CURVES

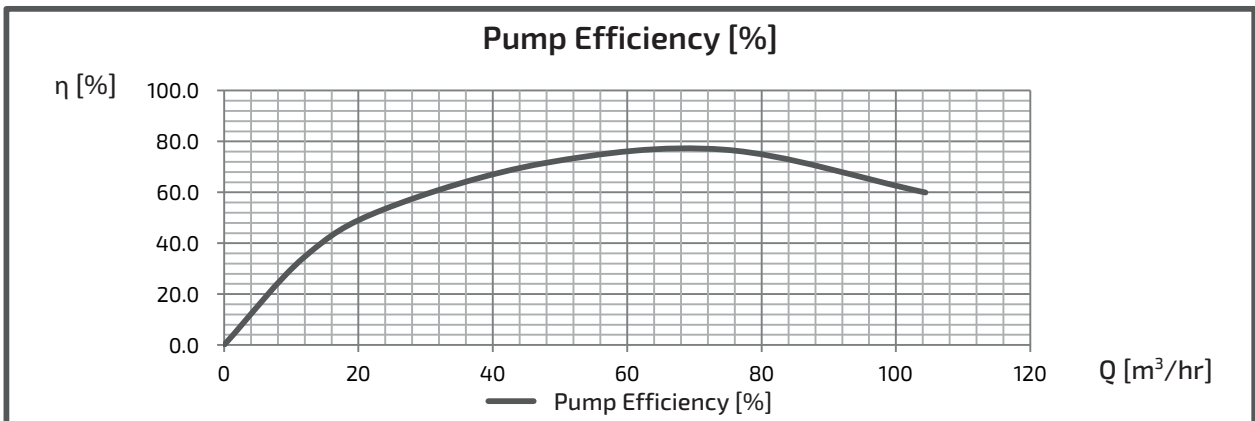
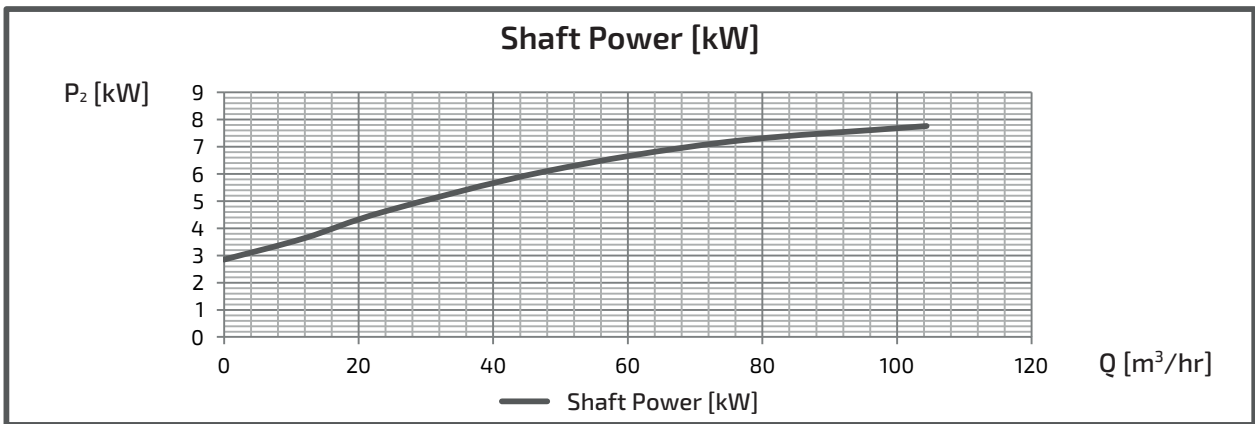
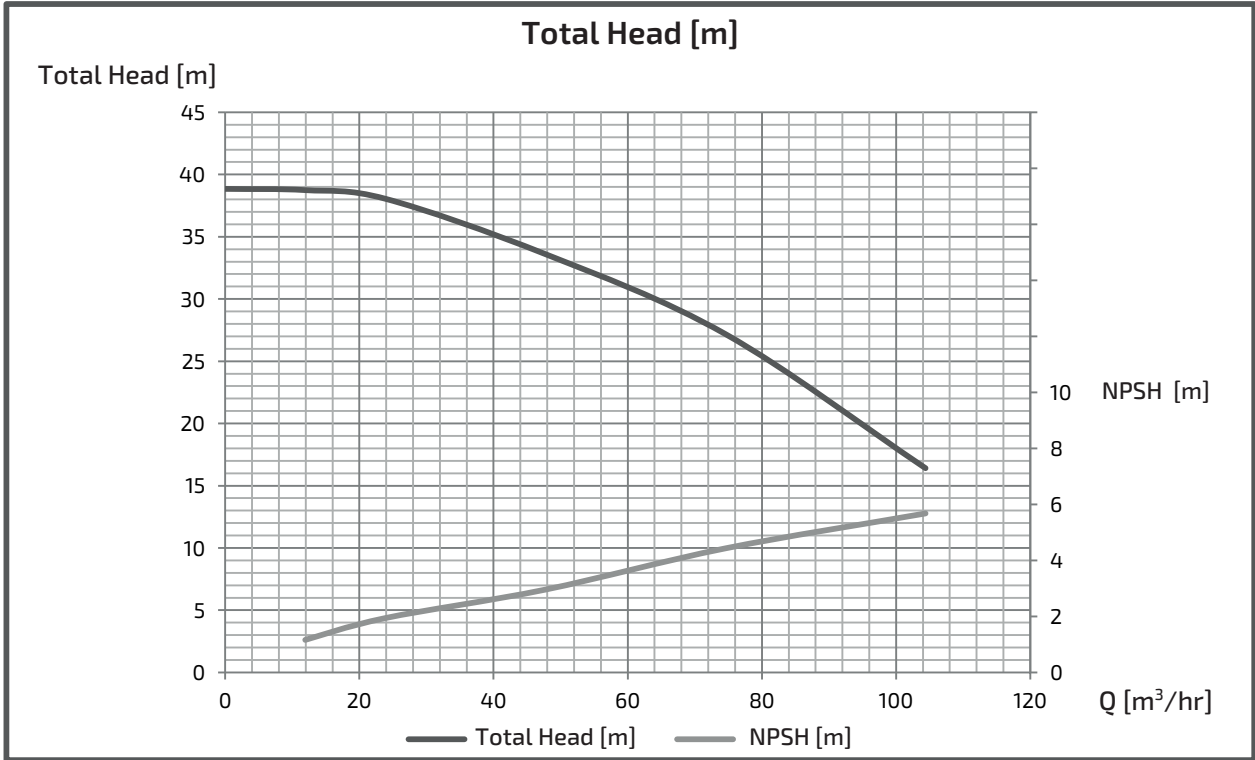

INDIVIDUAL EXPECTED PERFORMANCE CURVE

MODEL : GEK805M(G)2ME11

■ PERFORMANCE CURVES

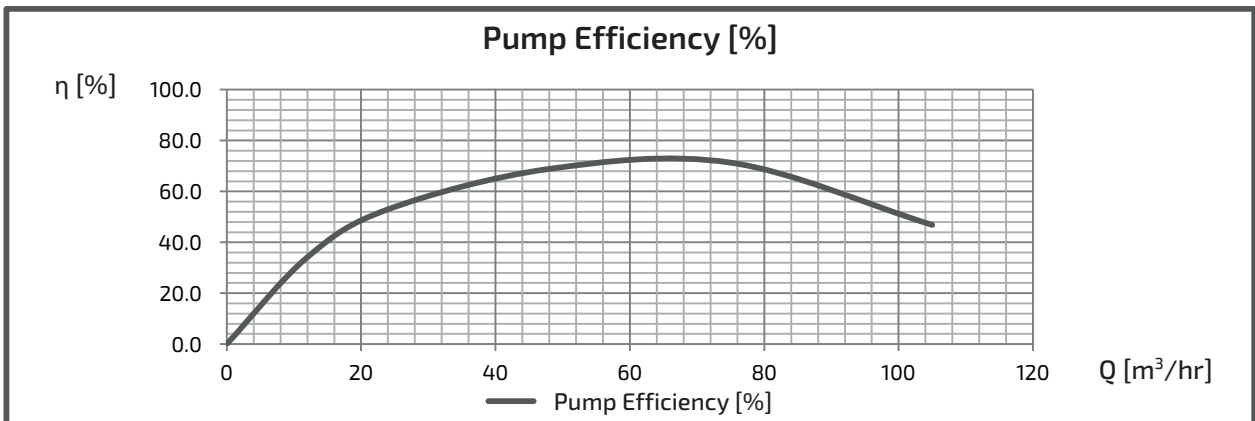
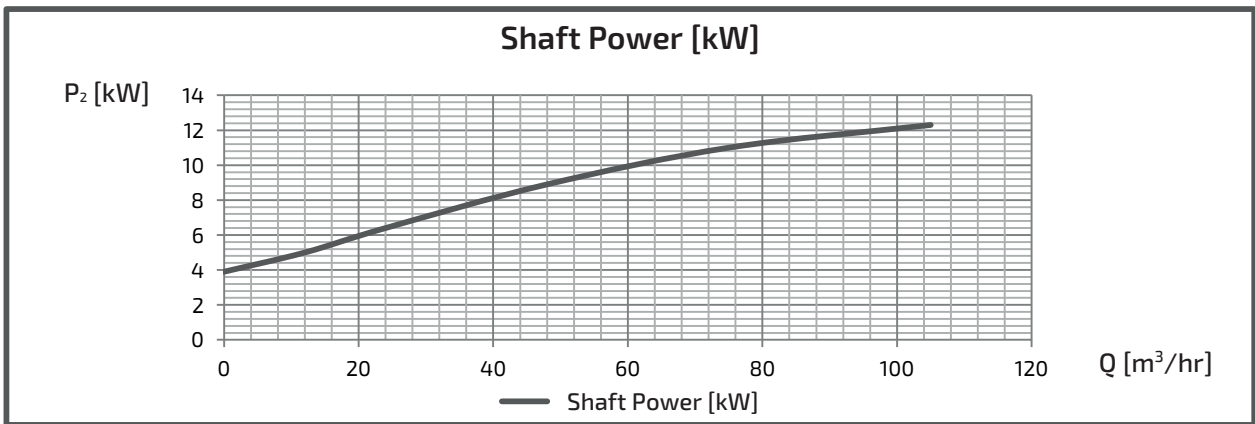
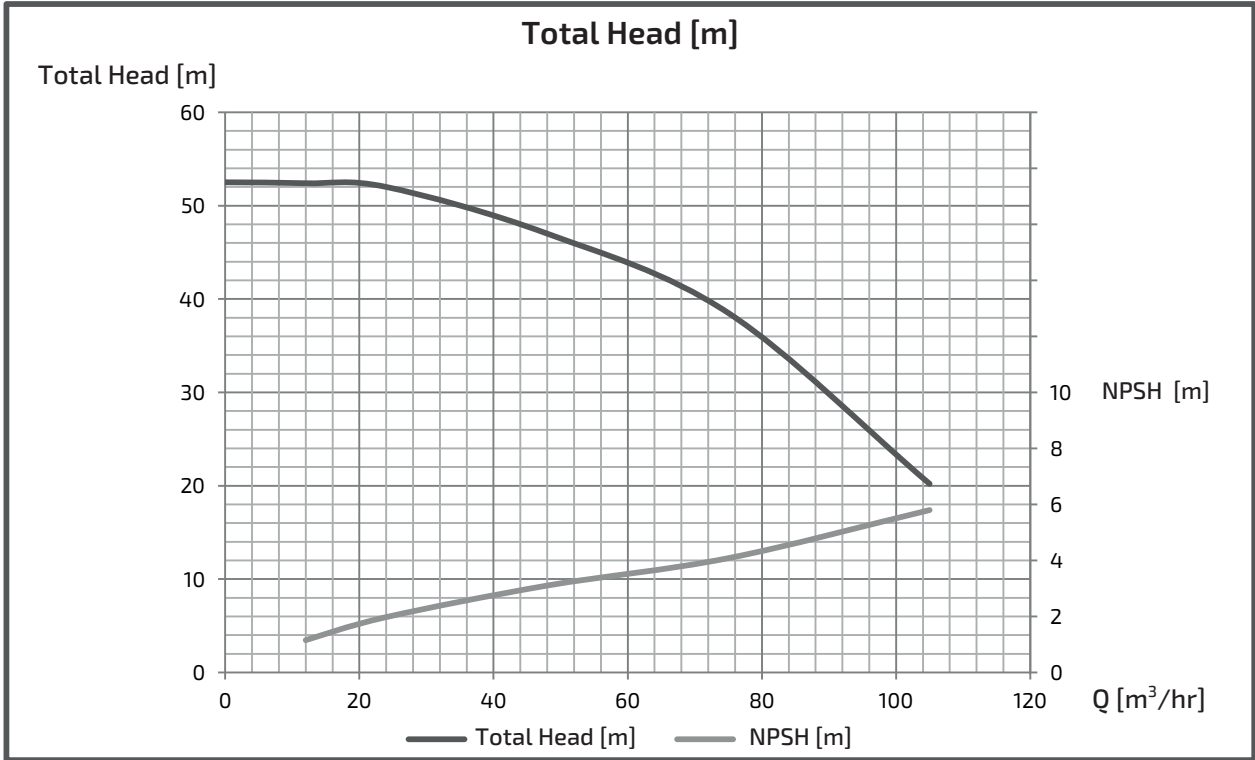

INDIVIDUAL EXPECTED PERFORMANCE CURVE

MODEL : GEK805M(G)2ME15

■ PERFORMANCE CURVES

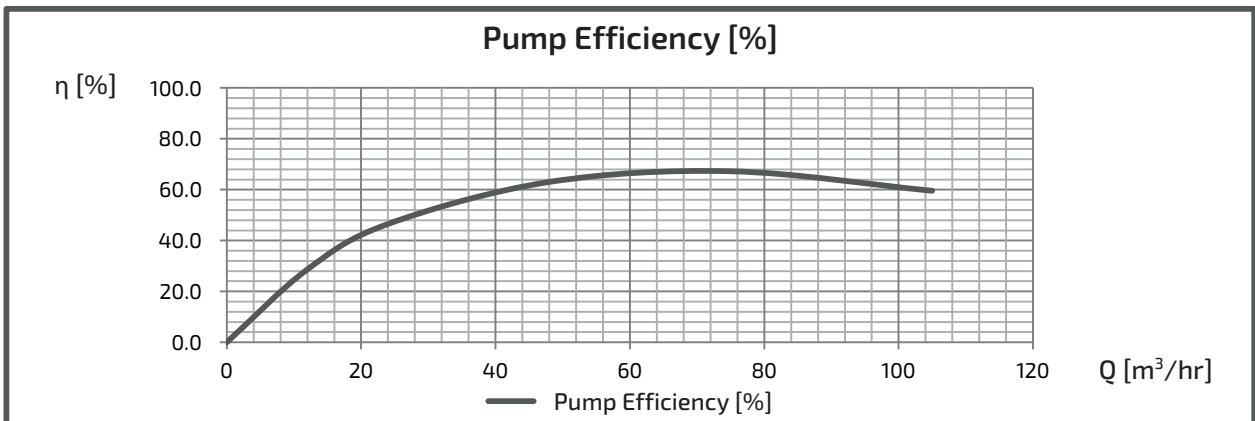
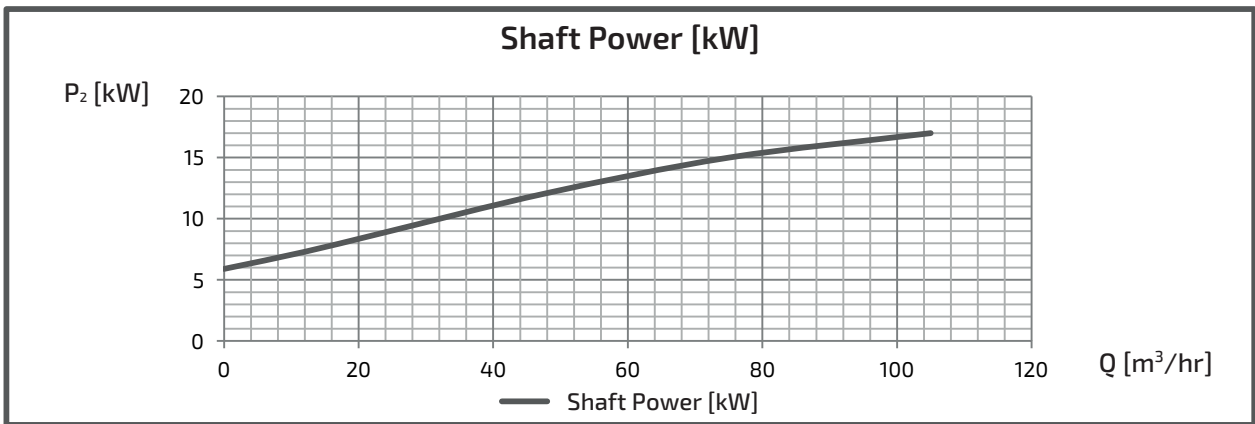
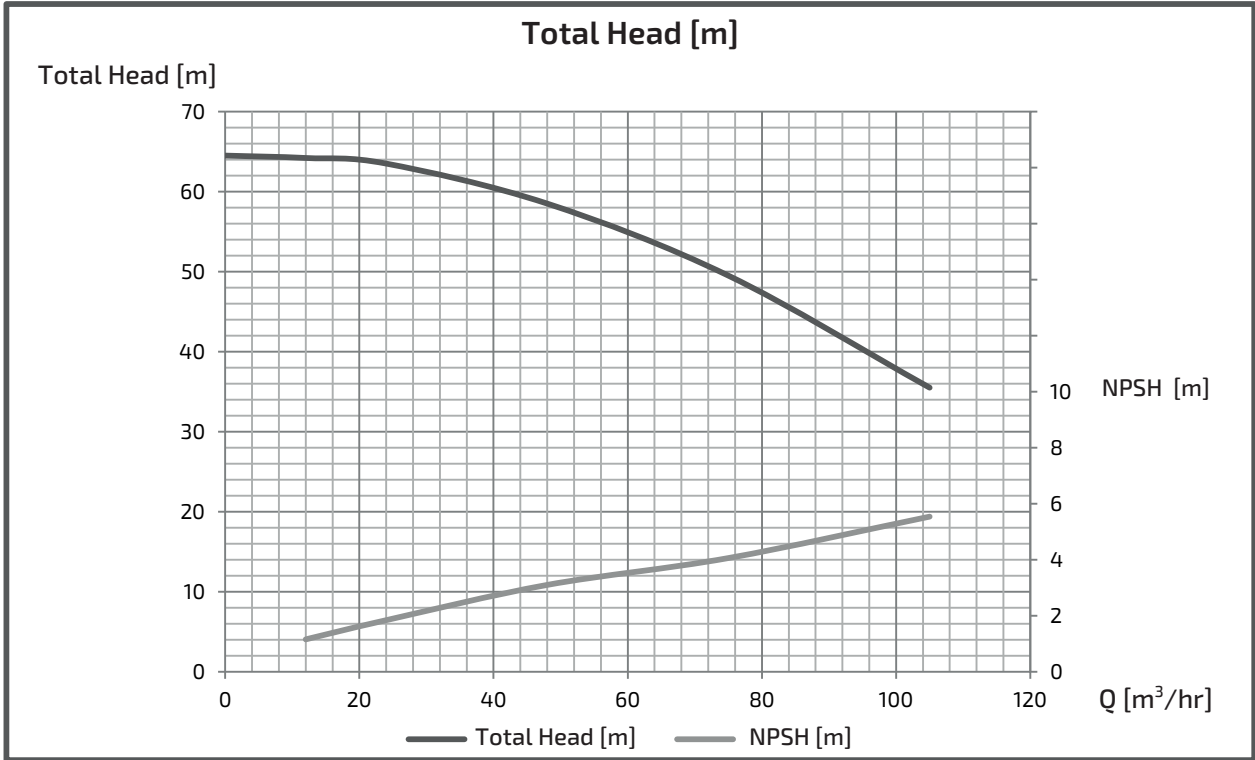

INDIVIDUAL EXPECTED PERFORMANCE CURVE

MODEL : GEL805M(G)2ME18

■ PERFORMANCE CURVES

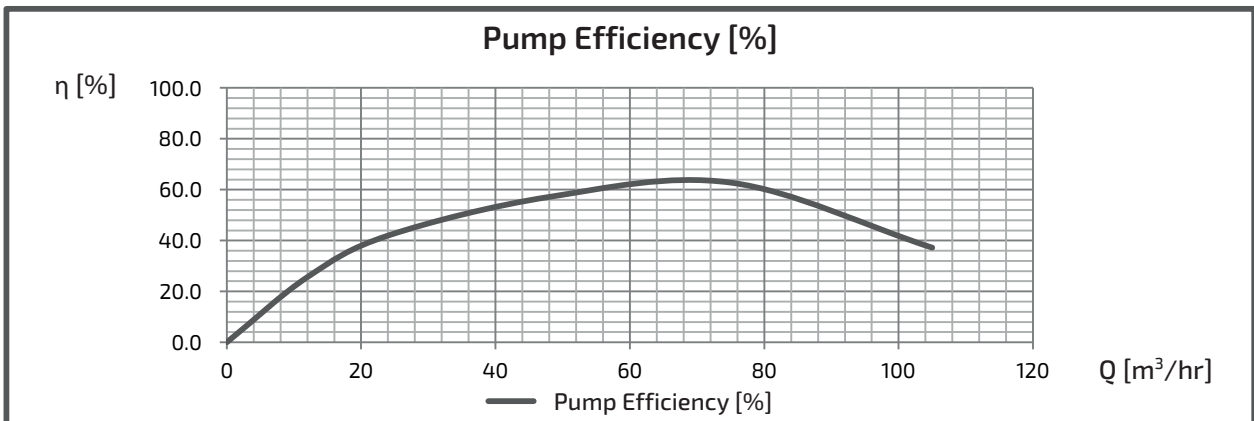
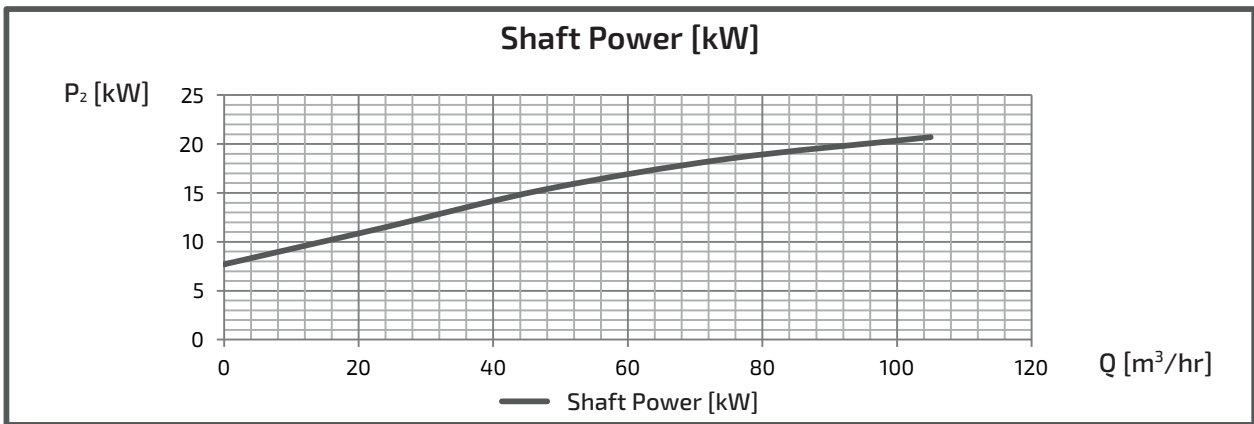
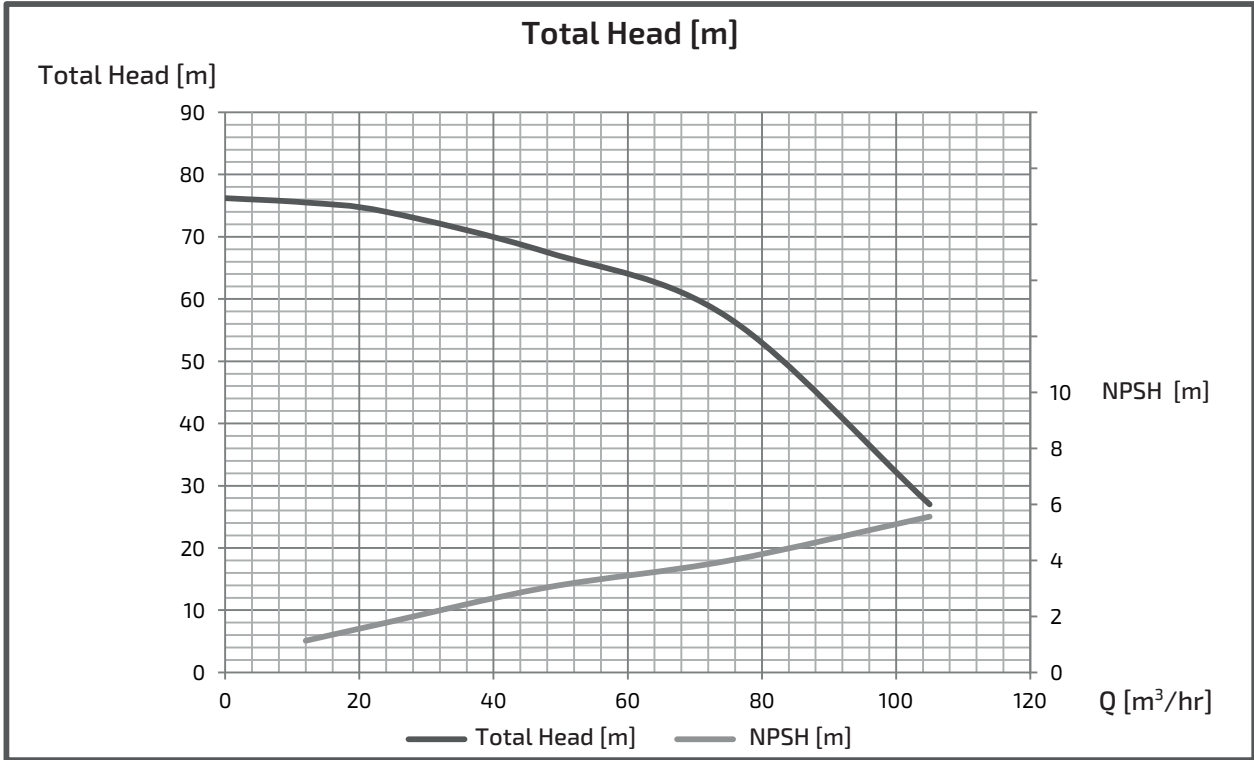

INDIVIDUAL EXPECTED PERFORMANCE CURVE

MODEL : GEL805M(G)2ME22

■ PERFORMANCE CURVES

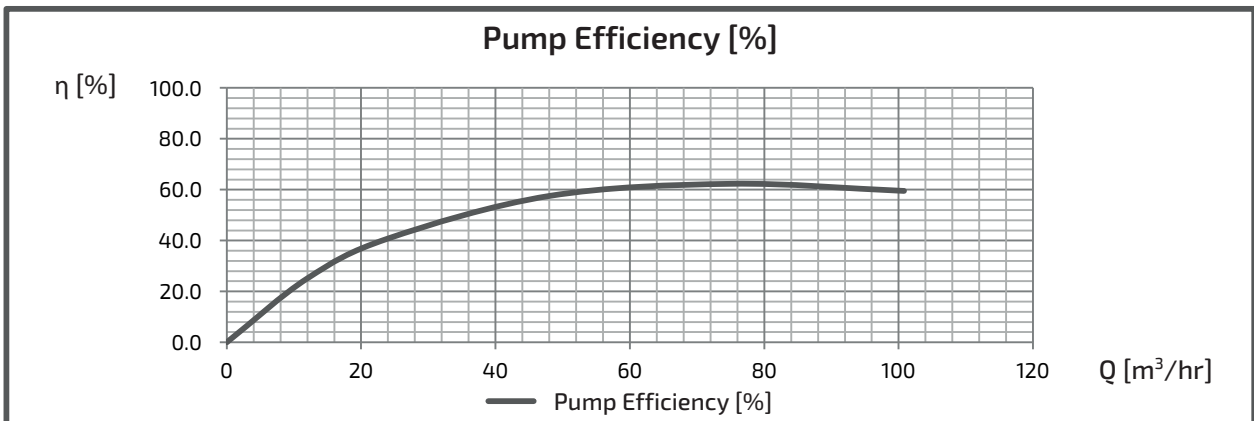
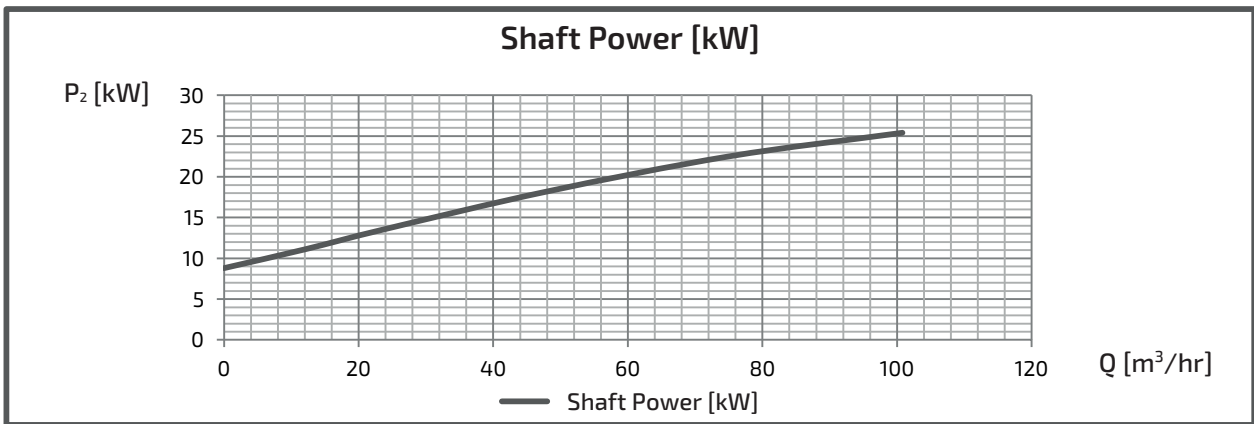
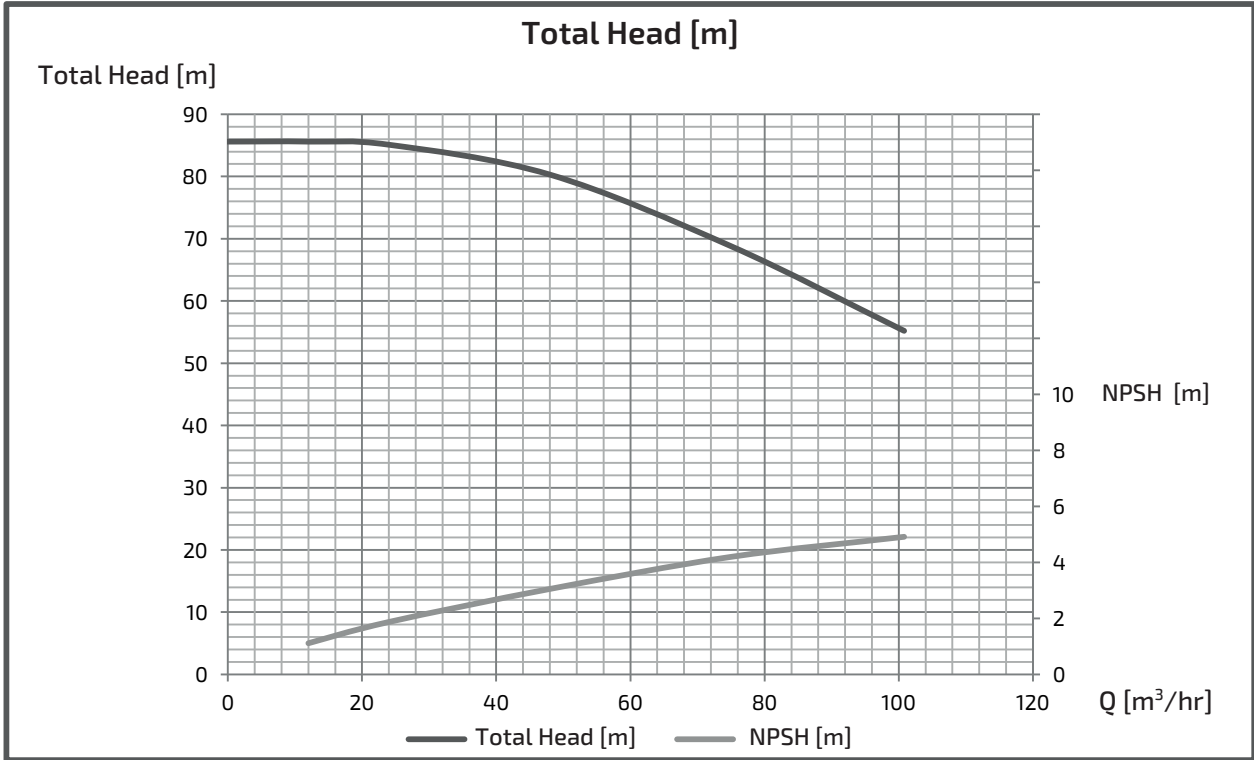

INDIVIDUAL EXPECTED PERFORMANCE CURVE

MODEL : GE1005M(G)2ME7.5

■ PERFORMANCE CURVES

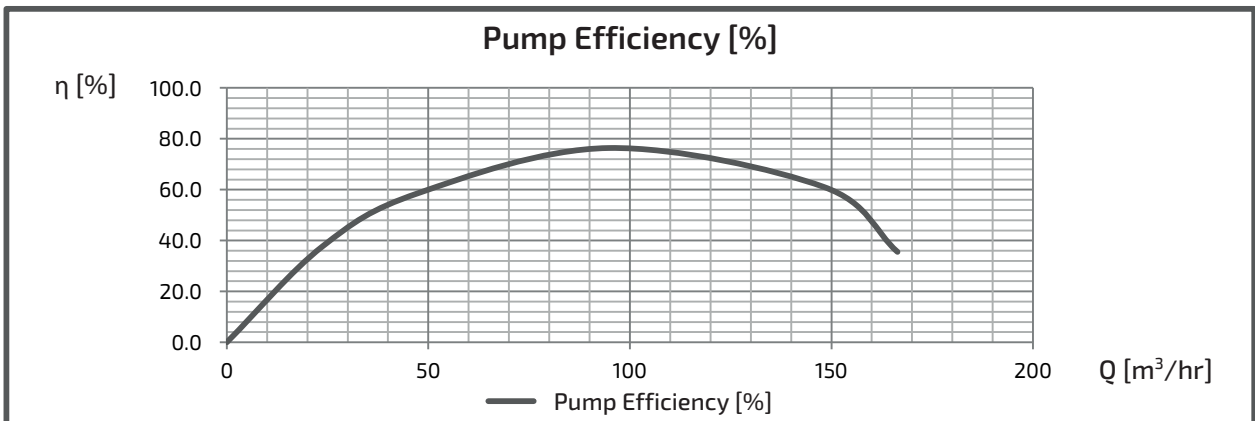
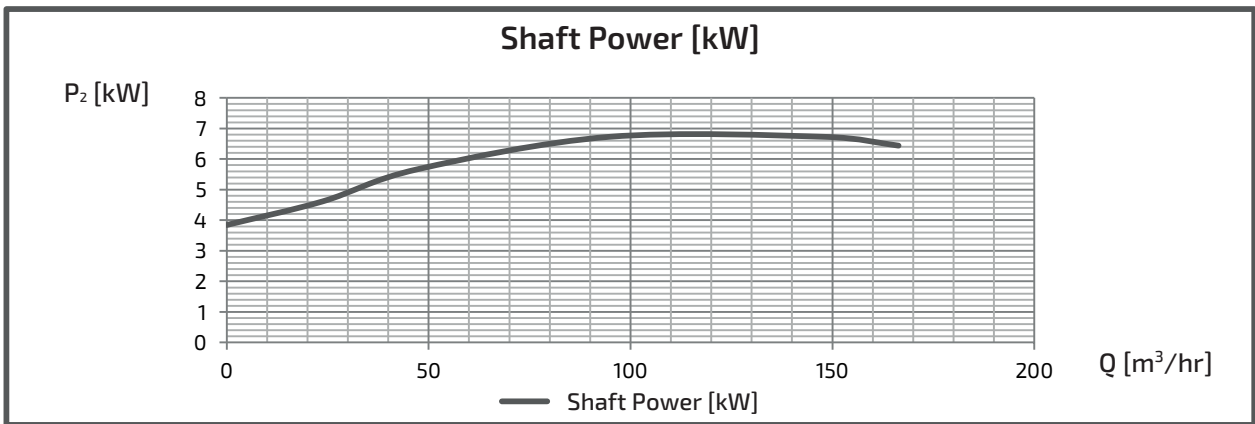
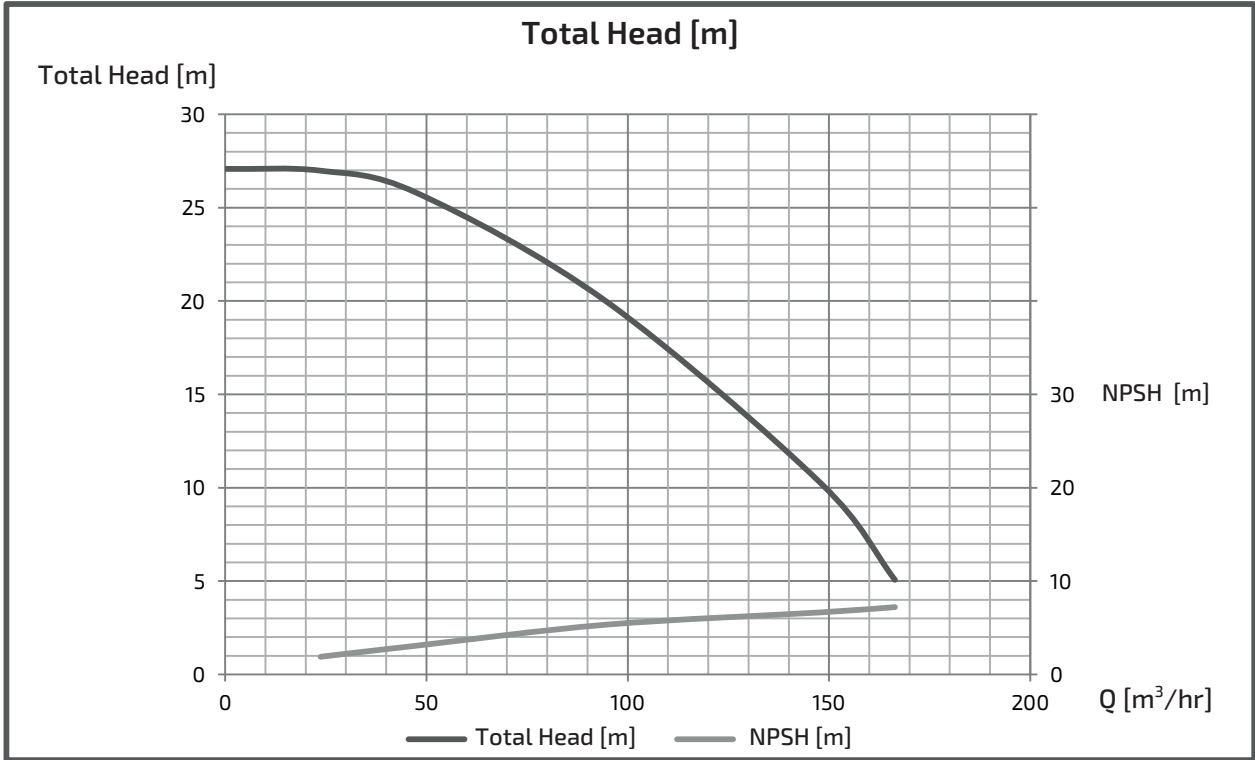

INDIVIDUAL EXPECTED PERFORMANCE CURVE

MODEL : GEJ1005M(G)2ME11

■ PERFORMANCE CURVES

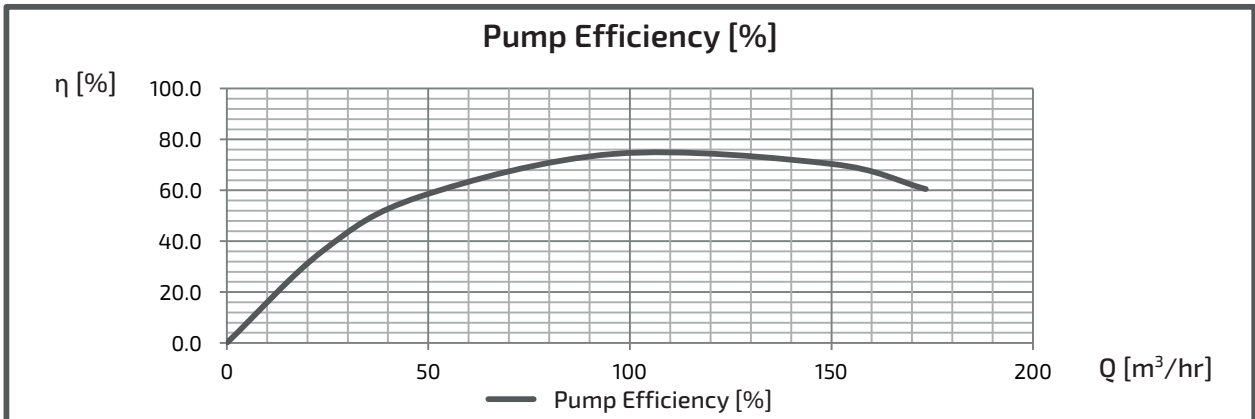
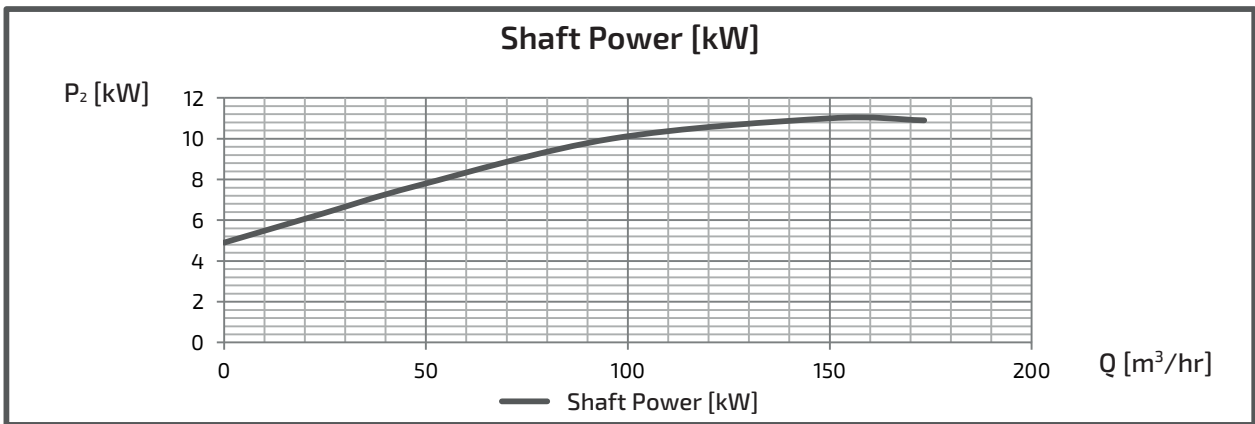
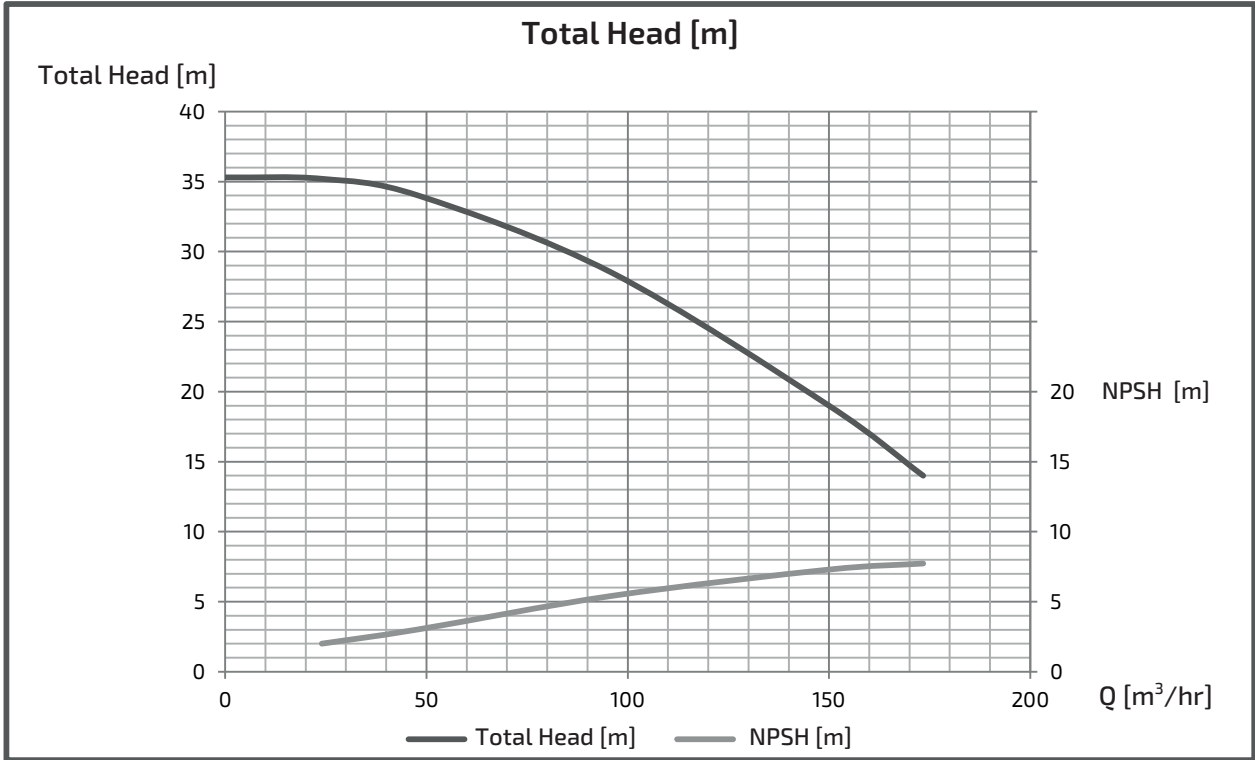

INDIVIDUAL EXPECTED PERFORMANCE CURVE

MODEL : GEJ1005M(G)2ME15

■ PERFORMANCE CURVES

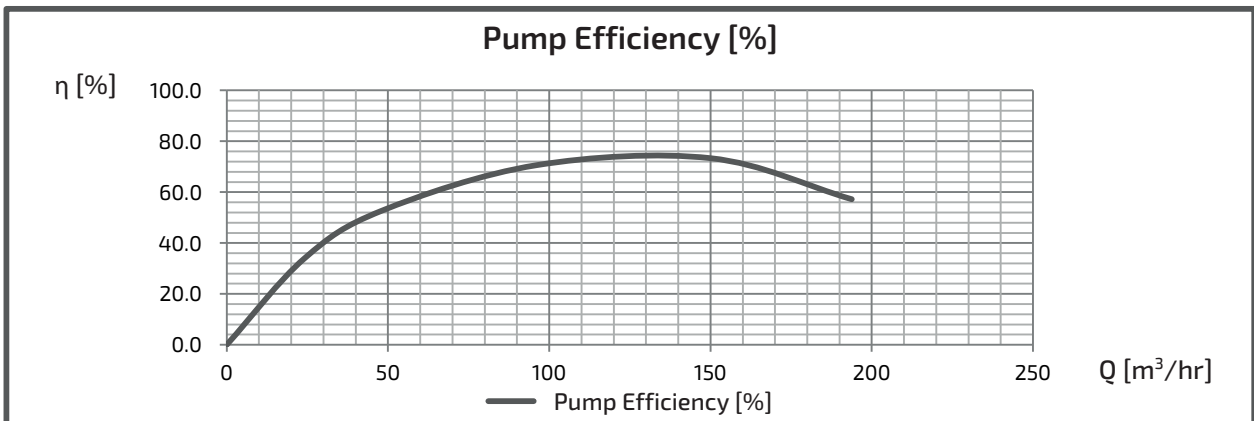
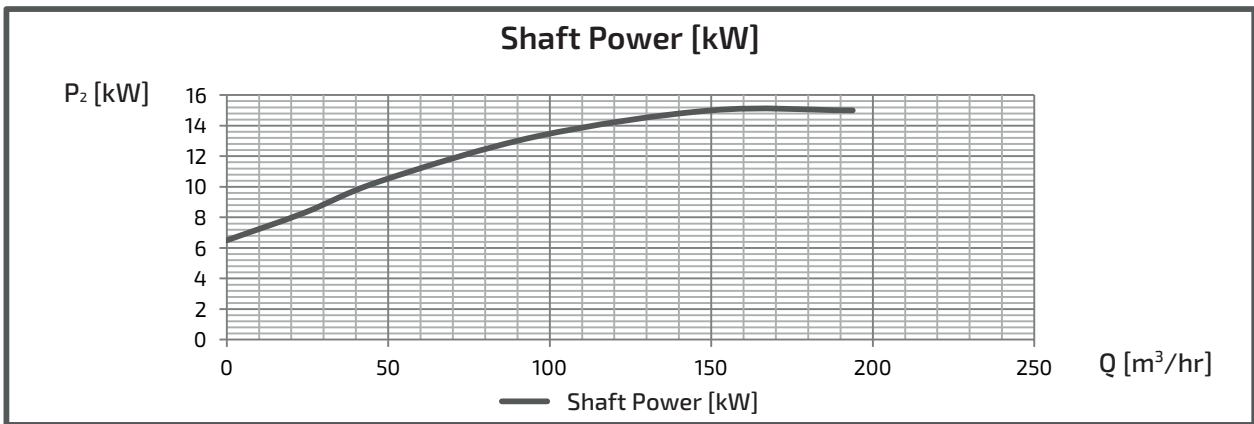
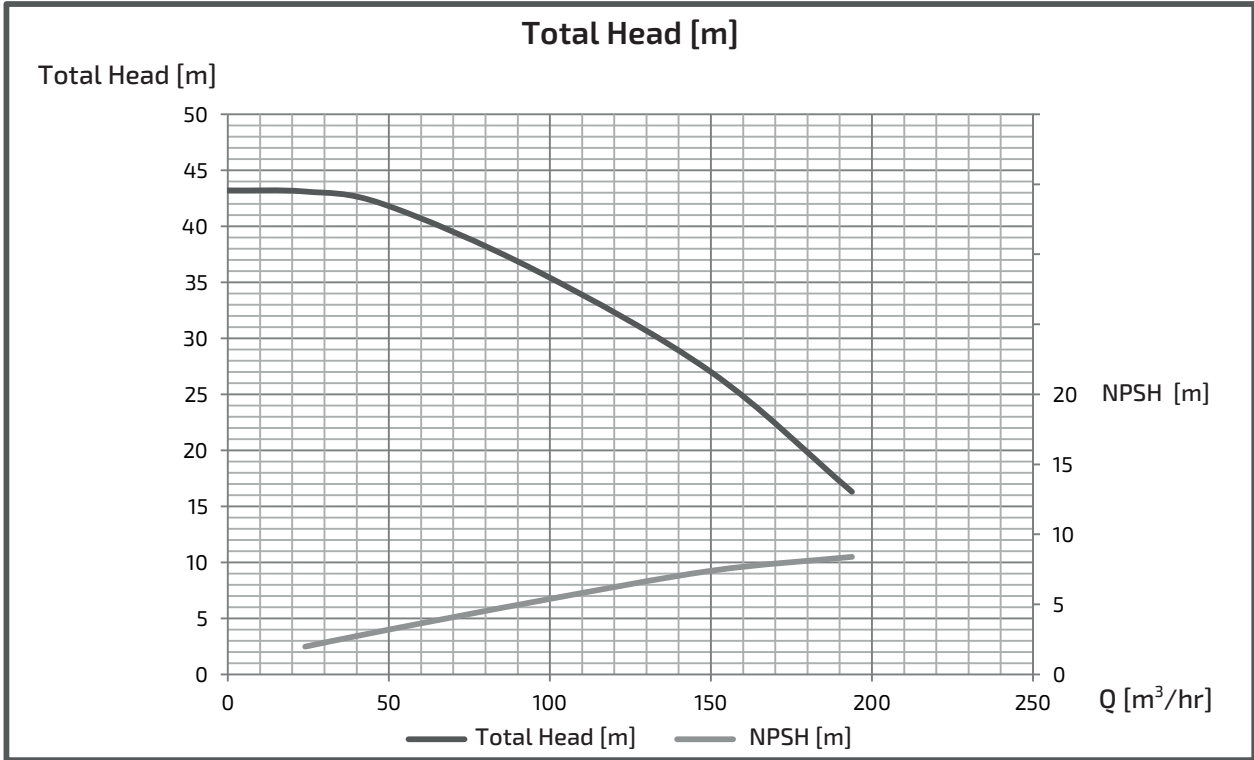

INDIVIDUAL EXPECTED PERFORMANCE CURVE

MODEL : GEK1005M(G)2ME18

■ PERFORMANCE CURVES

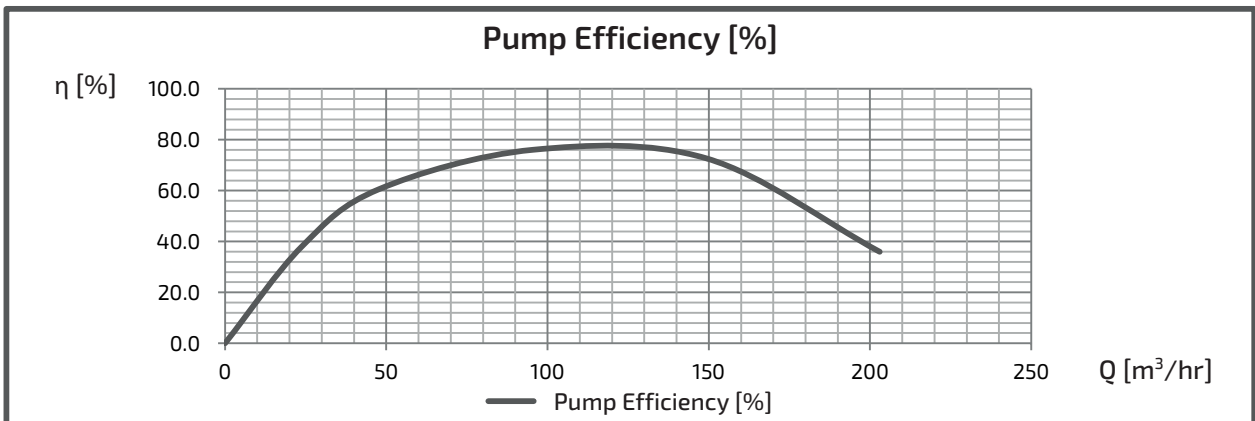
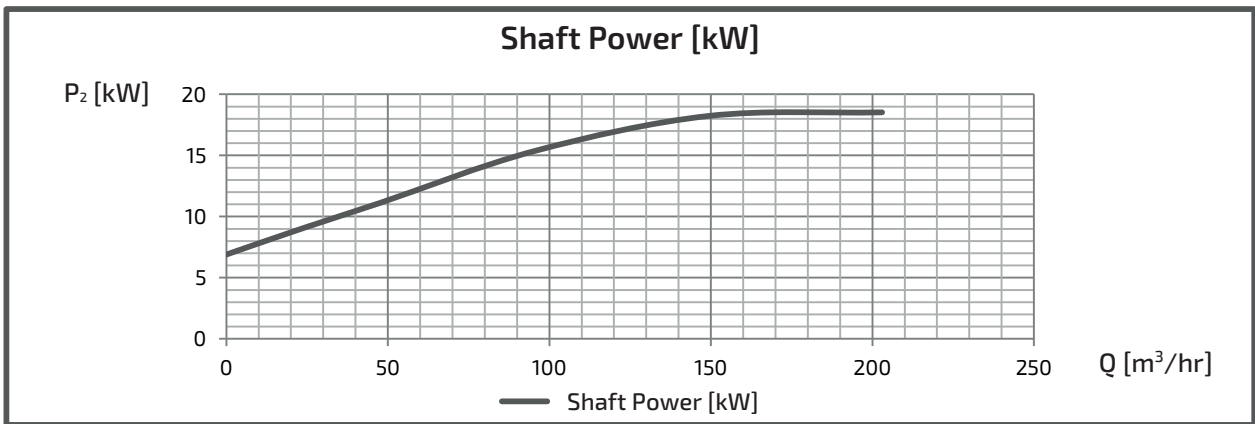
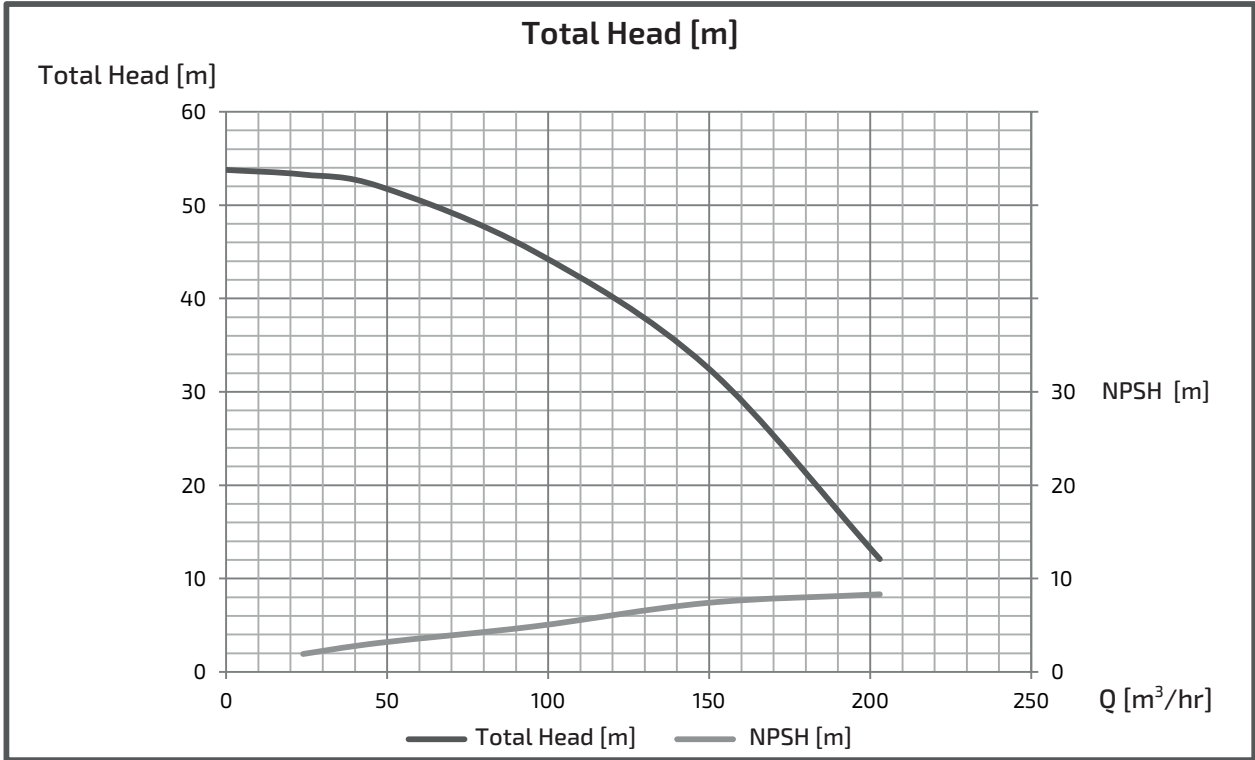

INDIVIDUAL EXPECTED PERFORMANCE CURVE

MODEL : GEK1005M(G)2ME22

■ PERFORMANCE CURVES

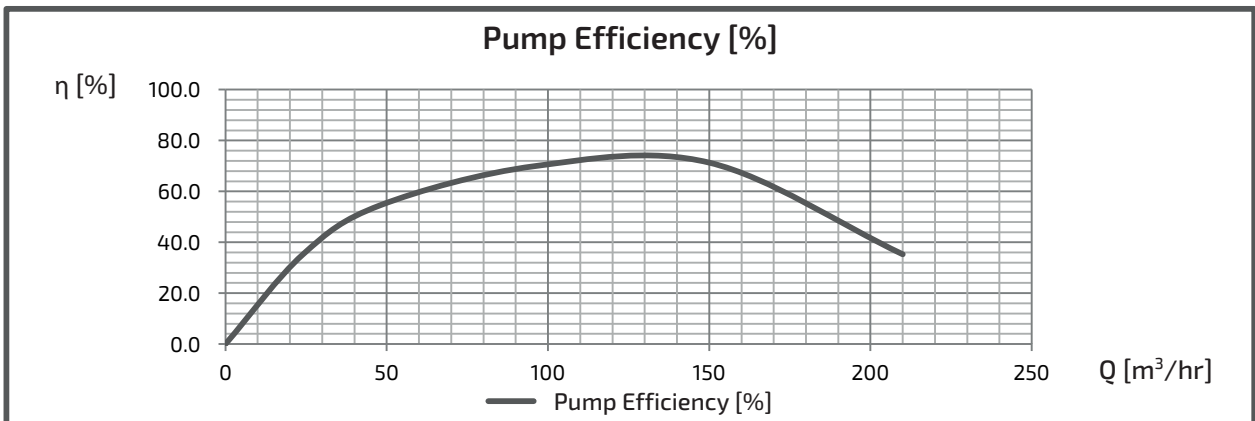
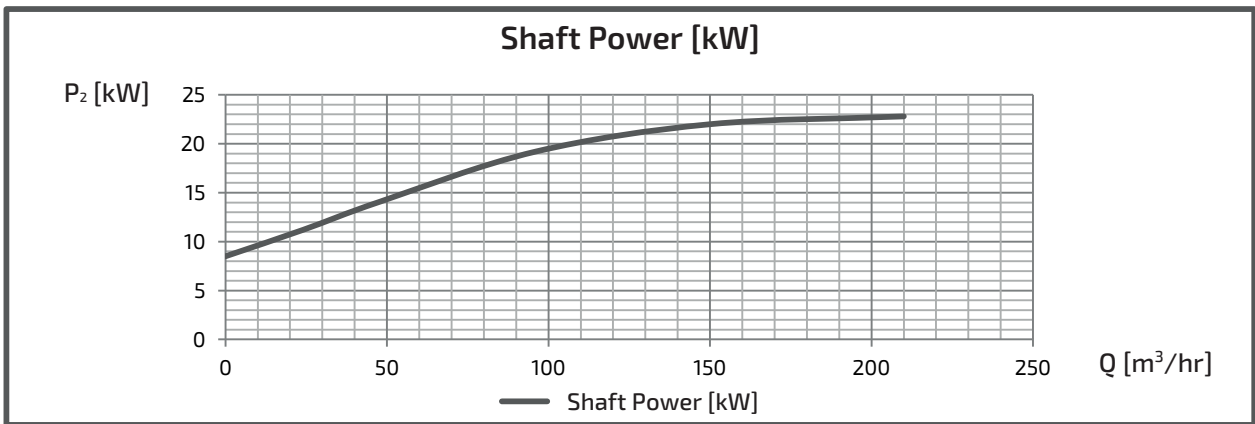
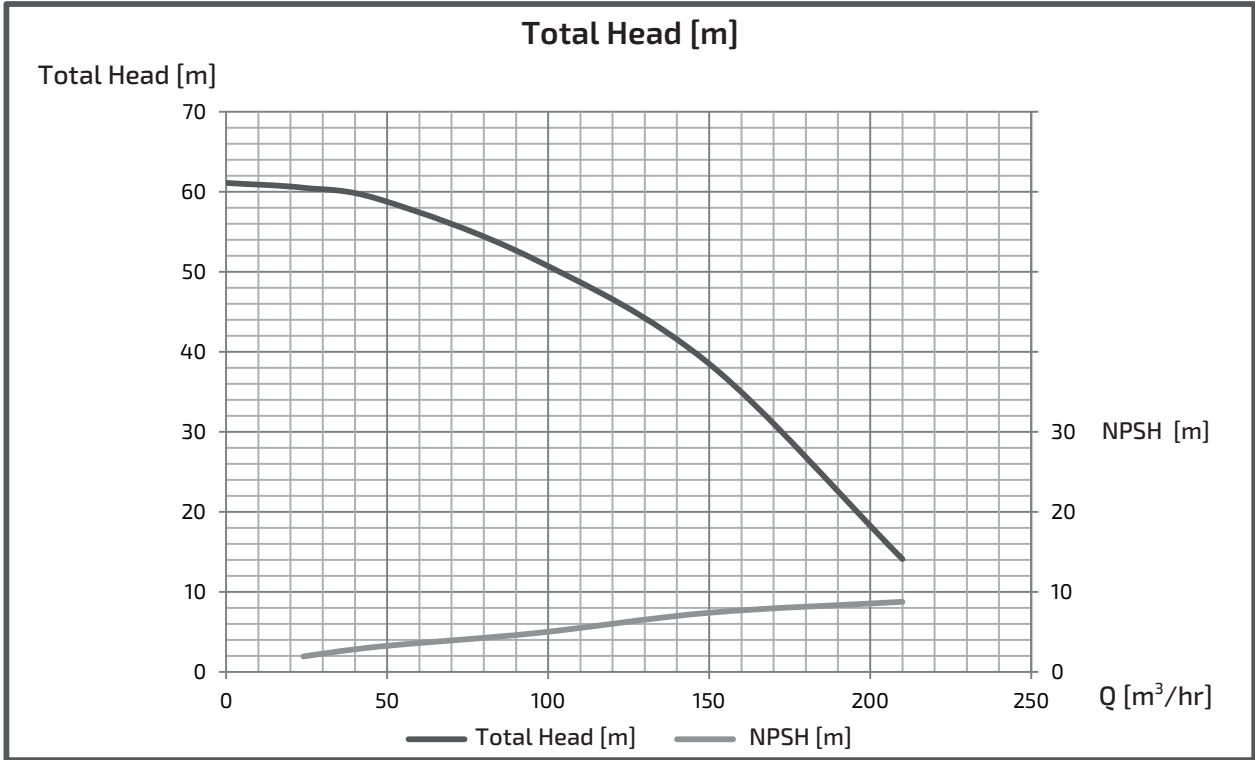

INDIVIDUAL EXPECTED PERFORMANCE CURVE

MODEL : GEL1005M(G)2ME30

■ PERFORMANCE CURVES

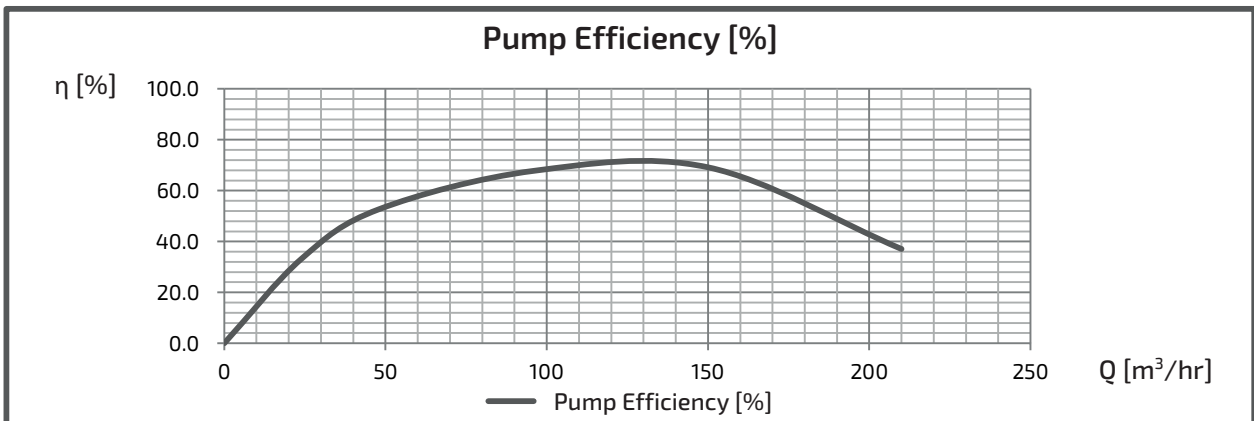
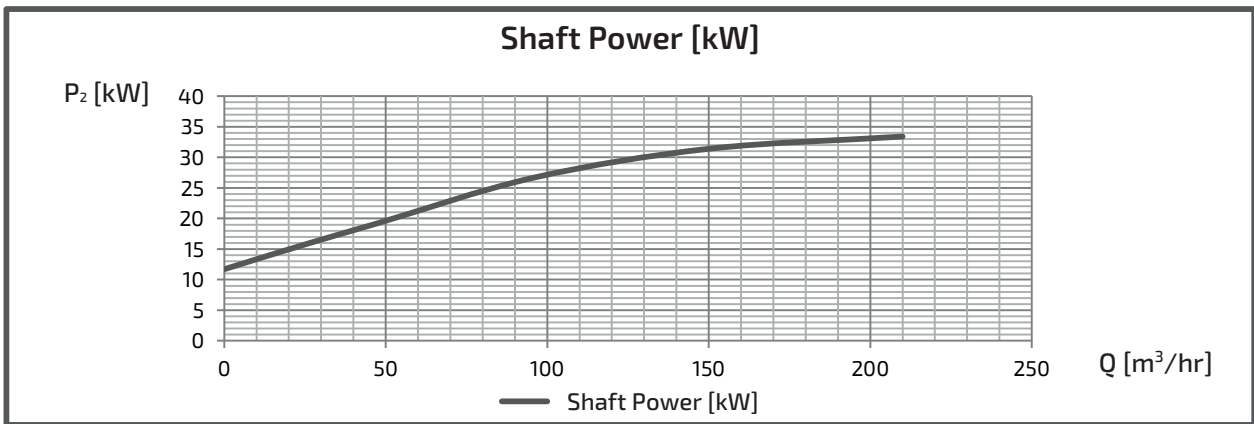
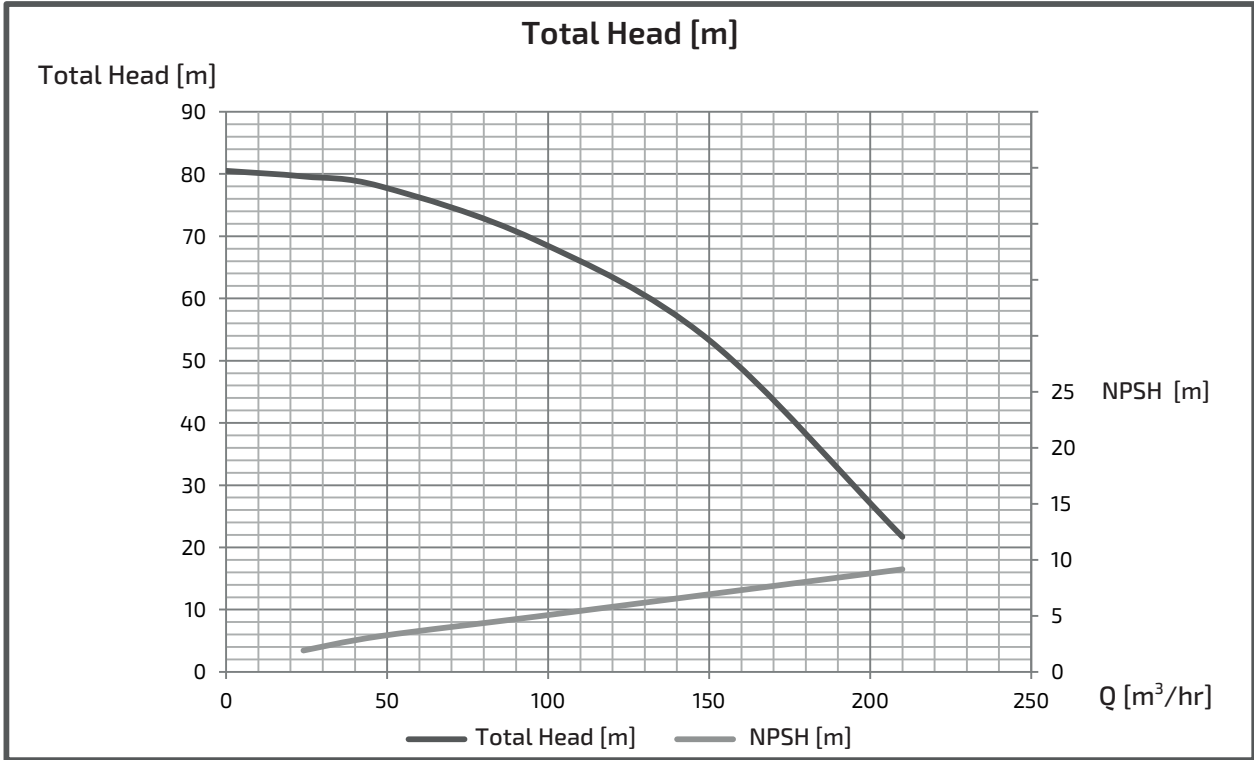

INDIVIDUAL EXPECTED PERFORMANCE CURVE

MODEL : GEL1005M(G)2ME37

■ PERFORMANCE CURVES

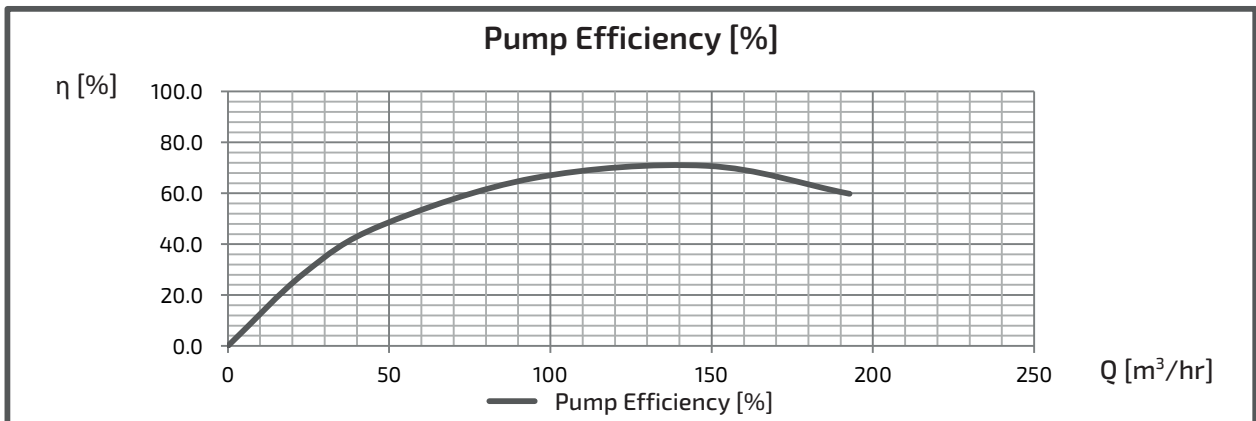
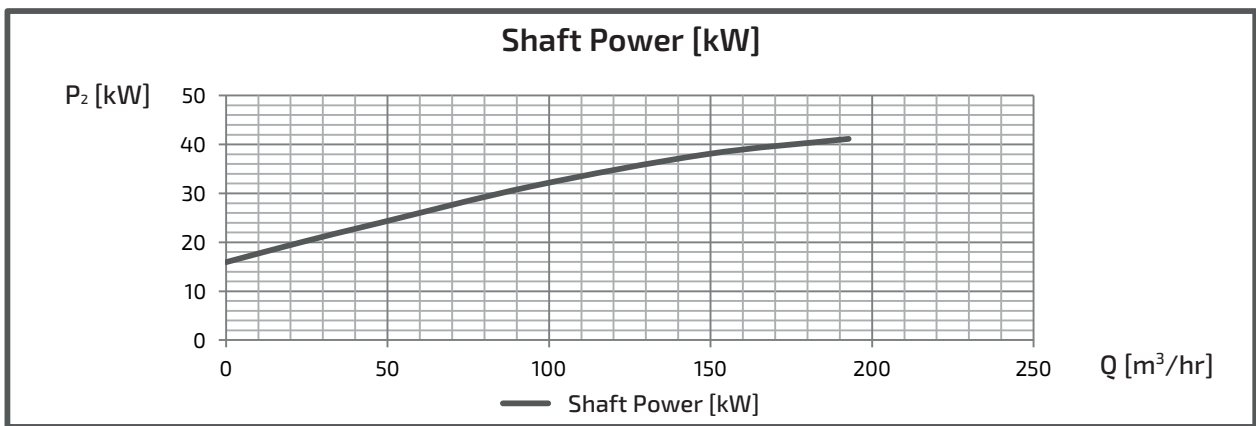
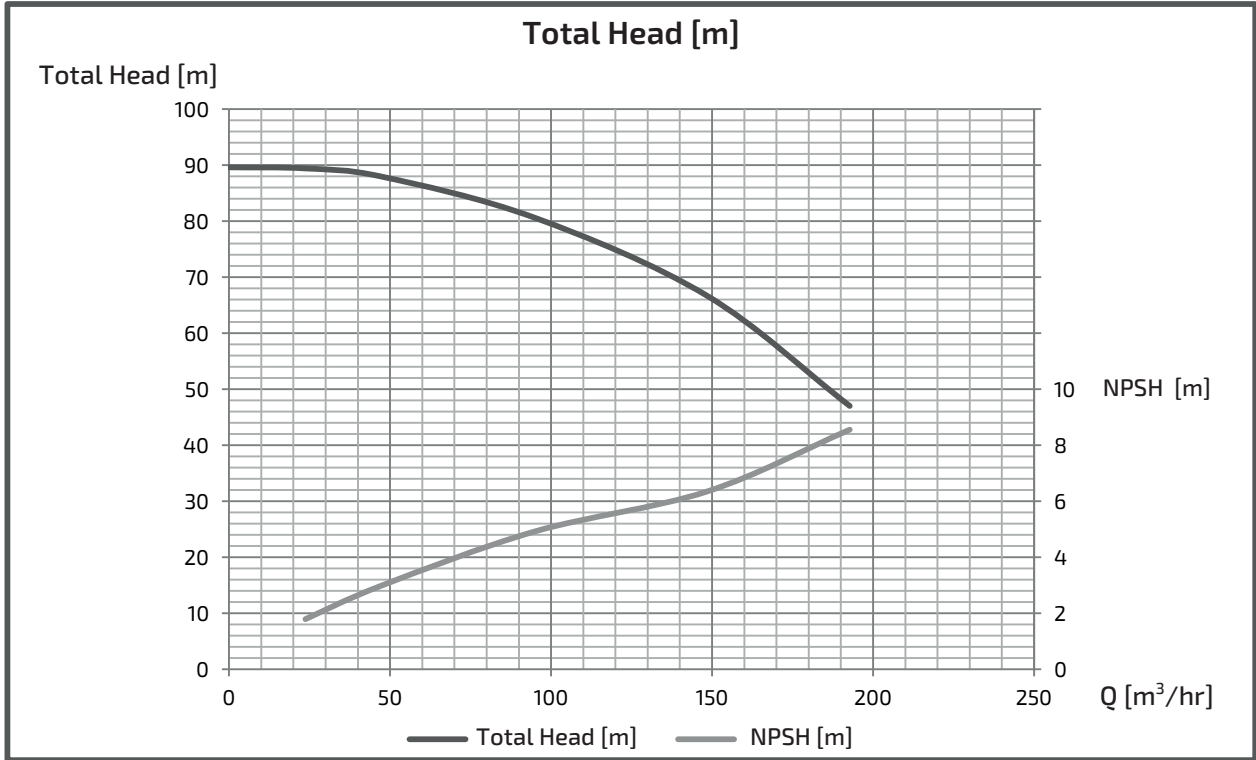

INDIVIDUAL EXPECTED PERFORMANCE CURVE

MODEL : GEL1005M(G)2ME45

■ PERFORMANCE CURVES

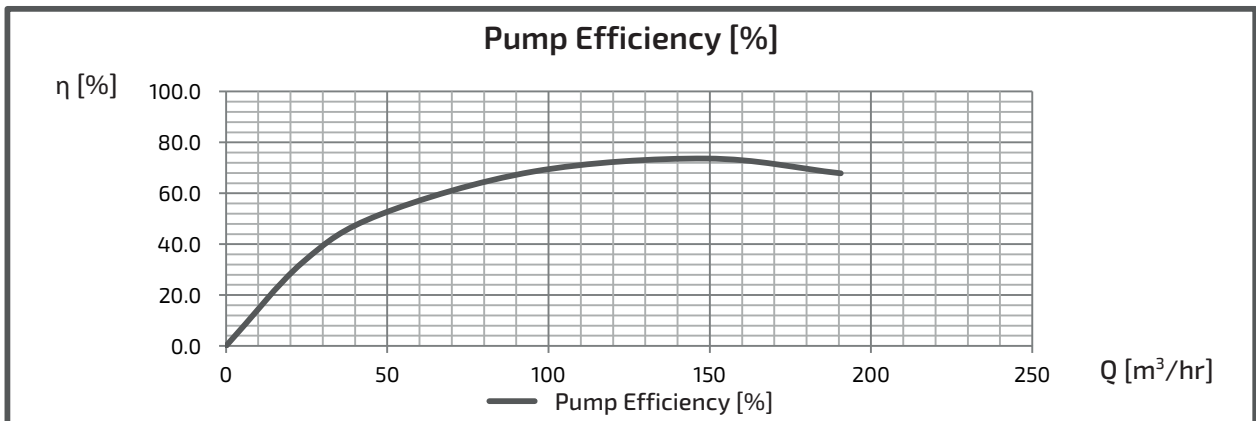
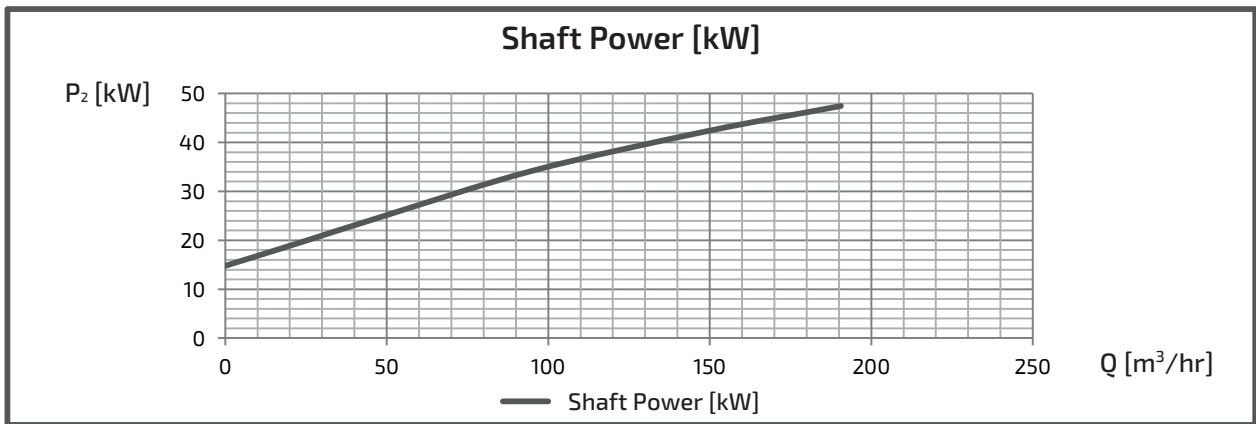
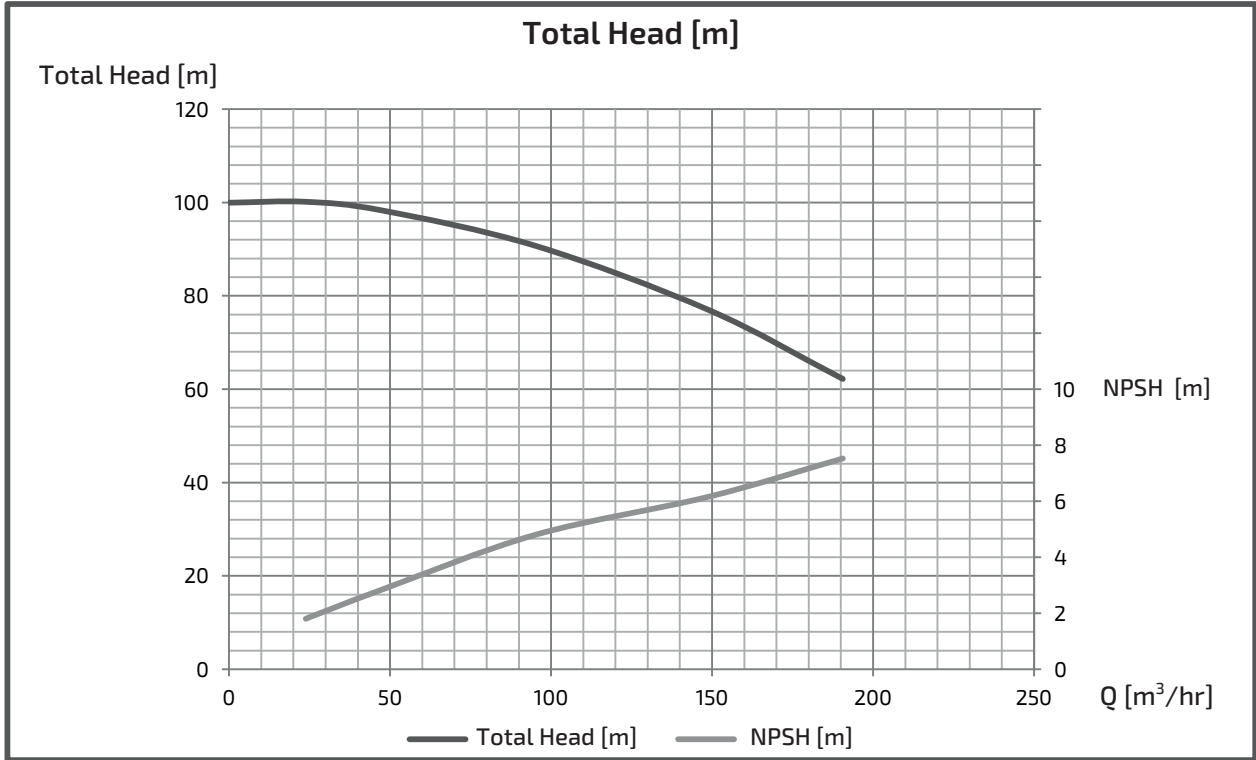

IMPORTANT SAFETY PRECAUTIONS

Always read the manual thoroughly and fully comprehend the contents for safe operation before starting use. Precautions for using products safely and for preventing personal injuries or physical damage are given in the manual.

- Matters falling under the following may not be covered by the warranty: uses out of the specified scope of application, failure to comply with precautions, improper repairs and alterations, matters arising from natural disasters, matters arising from the installation environment (improper power source, foreign objects, sand etc.), non-compliance with laws and regulations or standards pertaining thereto, accidental or intentional damage or injury, replacement of consumable parts, defects due to resale, etc.
- Do not use the product for applications out of the product specifications. Doing so may cause electric shock, fire, water leakage, etc.
- Have spare equipment ready when using pumps for equipment for living things (fish farms, fish tanks, aquariums, etc.) or critical equipment.
- Pump failure may cause lack of oxygen and water quality deterioration, and may affect the lives of the living things.
When using pumps for equipment for living things (fish farms, fish tanks, aquariums, etc.), do not install the pump in the tank where the living things are put into. The current leakage or sealing liquid leak from the mechanical seal may cause the death of the living things.
- If used to transport food-related items, give due consideration to the materials used. Contamination by foreign objects may occur.
- Avoid using for living things which disagrees with copper alloy. It may affect the lives of the living things.
- Select a product which is appropriate for your application. Inappropriate use of products may cause accidents.
- Conduct construction in accordance with the applicable laws and regulations (the Technical Standards of Electric Installation, interior wiring regulation, Building Standards Act, Water Supply Law, etc.). Not only does it violate the laws and regulations, but it also may cause injuries due to electric shock, fire, falling and tipping over.
- Do not use in places where people are assumed to get in contact with the product (baths, pools, lakes, etc.). Electric leak may occur and cause electric shock.
- Depending on the equipment, attach a filter etc. appropriate for your application on the discharge side before use, perform thorough flushing to check that there is no contamination. Cutting oil, rubber mold releasing agent, foreign objects etc. from the manufacturing line and cutting oil, foreign objects etc. from the pipeline may contaminate the liquid which is to be handled.
- Do not operate pumps with a specification of 50Hz at 60Hz. It may cause damage due to overpressure or burn damage of motors etc. due to overload. Do not operate pumps with a specification of 60Hz at 50Hz. Pump performance may be reduced.
- Only repair technicians may disassemble, repair, modify the product or replace cables. Defects may cause failure, damage, electrification or fire.
- It is recommended that both periodic and daily inspections be performed in order to ensure that the pump will operate reliably for as long as possible. Failure to perform inspections may lead to pump failure, accidents etc. For periodic inspections, please consult your distributor or our nearest sales office.

Note

Specifications/Configurations may be altered as a result of improvements and such.
Unauthorized reproduction of this document is prohibited.